



# SUZUKI MARINE

Parts Book

DT 9.9 (1983-1985)



1703 Hwy 35 So., Laurence Harbor, NJ 08879

**(732) 264-7176**

**(800) 338-0645 FAX (732) 264-2472**

[www.brownspoint.com](http://www.brownspoint.com)

PREFACE

When it becomes necessary to replace parts on SUZUKI OUTBOARD MOTORS, always use SUZUKI GENUINE PARTS which have passed a strict inspection which guarantees quality and performance.

This parts catalogue covers the list of all service parts for SUZUKI DT9.9 QD/VE/VF.

The basic model of this parts catalogue is DT9.9 QD/VE/VF.

INSTRUCTIONS FOR QUOTING THE CATALOGUE

1. DIMENSIONS

Dimensions of the parts in this catalogue are indicated in unit millimeters.

2. ABBREVIATIONS

Abbreviations used in this catalogue are as follows:

- |       |                        |           |                   |
|-------|------------------------|-----------|-------------------|
| AR    | : As required          | NT        | : Number of teeth |
| ASSY  | : Assembly             | OPT       | : Optional        |
| E.No. | : Engine number        | OS        | : Over size       |
| F.No. | : Frame number         | STD       | : Standard        |
| d     | : Diameter of material | T         | : Thickness       |
| ID    | : Inside diameter      | US        | : Under size      |
| OD    | : Outside diameter     | W         | : Width           |
| L     | : Length               | S,L,UL,LL | : Transom type    |
| LH    | : Left hand side       |           |                   |
| RH    | : Right hand side      |           |                   |

$\frac{12}{\text{ID}} \times \frac{34}{\text{OD}} \times \frac{5.6}{\text{T(or W,L)}}$  ..... Figures in the description column show the dimensions of parts.

3. INNER PARTS OF ASSEMBLY

Part name with a dot (.) in front as shown in the description column indicates the component of the assembly also available individually.

4. MODIFICATION NOTICE

A parts bulletin will be sent to you on all occasions when changes in parts occur, including interchangeable modifications between new parts and old ones.

5. NOTE

5-1. There are some different parts from those of production models among spare parts for the administrative reasons and common use of them with other models.

5-2. In respect of rubber hoses and vinyl tubes, please be sure to use them by cutting off according to the length mentioned on parts catalogue or what is actually required on the vehicle.

5-3. Note that the drawings on the illustration page are for ready reference of spare parts number, not to be used as an assembly manual.  
When assembling, use "SUZUKI SERVICE MANUAL".

6. ENGINE NUMBER

DT9.9 QD : 00993-301001~306190  
DT9.9 VE : 00933-406191~412879  
DT9.9 VF : 00933-512880~

Year	Parts Model Year Designation	Example*	Sales Model Year Designation	Example
1977	C	Cxxxxx	B	DT50ELB
1978	D	Dxxxxx	C	DT50ELC
1979	F	Fxxxxx	N	DT50ELN
1980	G	Oxxxxx	T	DT85TCLT
1981	J	1xxxxx	X	DT140TCLX
1982	VZ	2xxxxx	Z	DT140TCLZ
1983	QD	3xxxxx	D	DT140TCXD
1984	VE	4xxxxx	E	DT140TCXE
1985	VF	5xxxxx	F	DT140TCXF

\*Engine number off clamp bracket

FIG.1

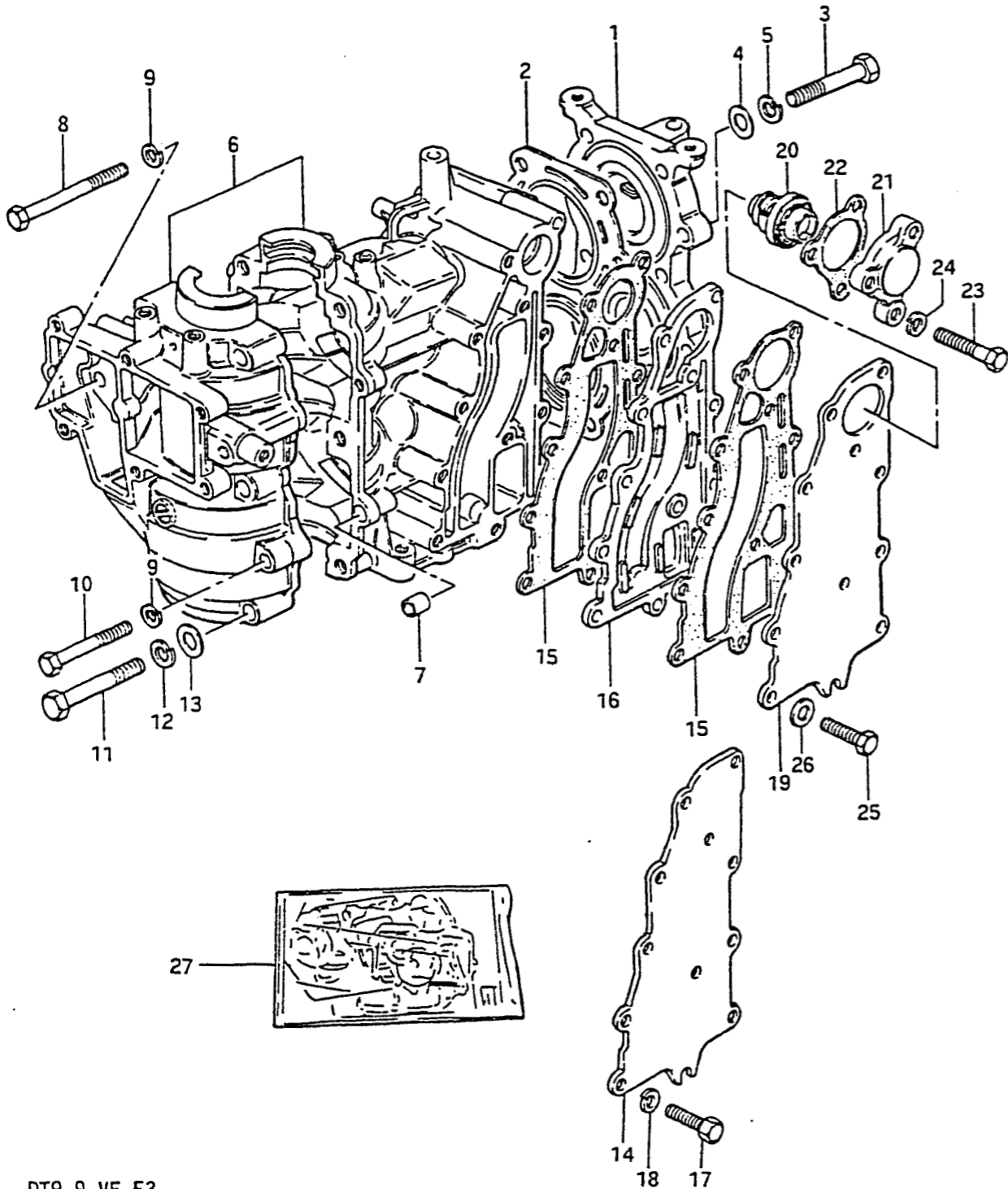

1

FIG.1 (B- 2) CYLINDER

REF.NO.	PART NO.	DESCRIPTION	Q'TY	REMARKS
1-1	11110-93900-02M	CYLINDER HEAD	1	~412879
1-2	11110-93930-02M	CYLINDER HEAD	1	512880~
2	11141-93900	GASKET, cylinder head	1	
3	01107-08408	BOLT	10	
4	08322-21088	WASHER	10	
5	08321-21088	LOCK WASHER	10	
6	11301-93900-02M	CYLINDER	1	
7	04211-09109	.KNOCK PIN	2	
8	09100-06038	.BOLT (6x65)	2	
9	08321-21068	.LOCK WASHER	4	
10	01107-06458	.BOLT	2	
11	01107-08458	.BOLT	6	
12	08321-21088	.LOCK WASHER	6	
13	08322-11088	.WASHER	6	
14	14141-93900-02M	COVER, exhaust	1	model QD/VE
15-1	14151-93900	GASKET, exhaust cover	2	~304868
15-2	14151-93901	GASKET, exhaust cover	2	304869~
16	14131-93900	PLATE, exhaust cover	1	
17	01107-06258	BOLT	12	model QD/VE
18	08322-21068	LOCK WASHER	12	model QD/VE
19	14141-93950-02M	COVER, exhaust	1	model VF
20	17670-93961	THERMOSTAT	1	
21	17681-93951-02M	COVER, thermostat	1	
22	17685-93950	GASKET, thermostat cover	1	
23	01107-06358	BOLT	3	
24	08321-21067	LOCK WASHER	3	
25	01107-06258	BOLT	9	model VF
26	08322-21067	WASHER	9	model VF
27-1	11400-93892	GASKET SET	1	OPT,~412879
27-2	11400-93893	GASKET SET	1	OPT,512880~

FIG.2

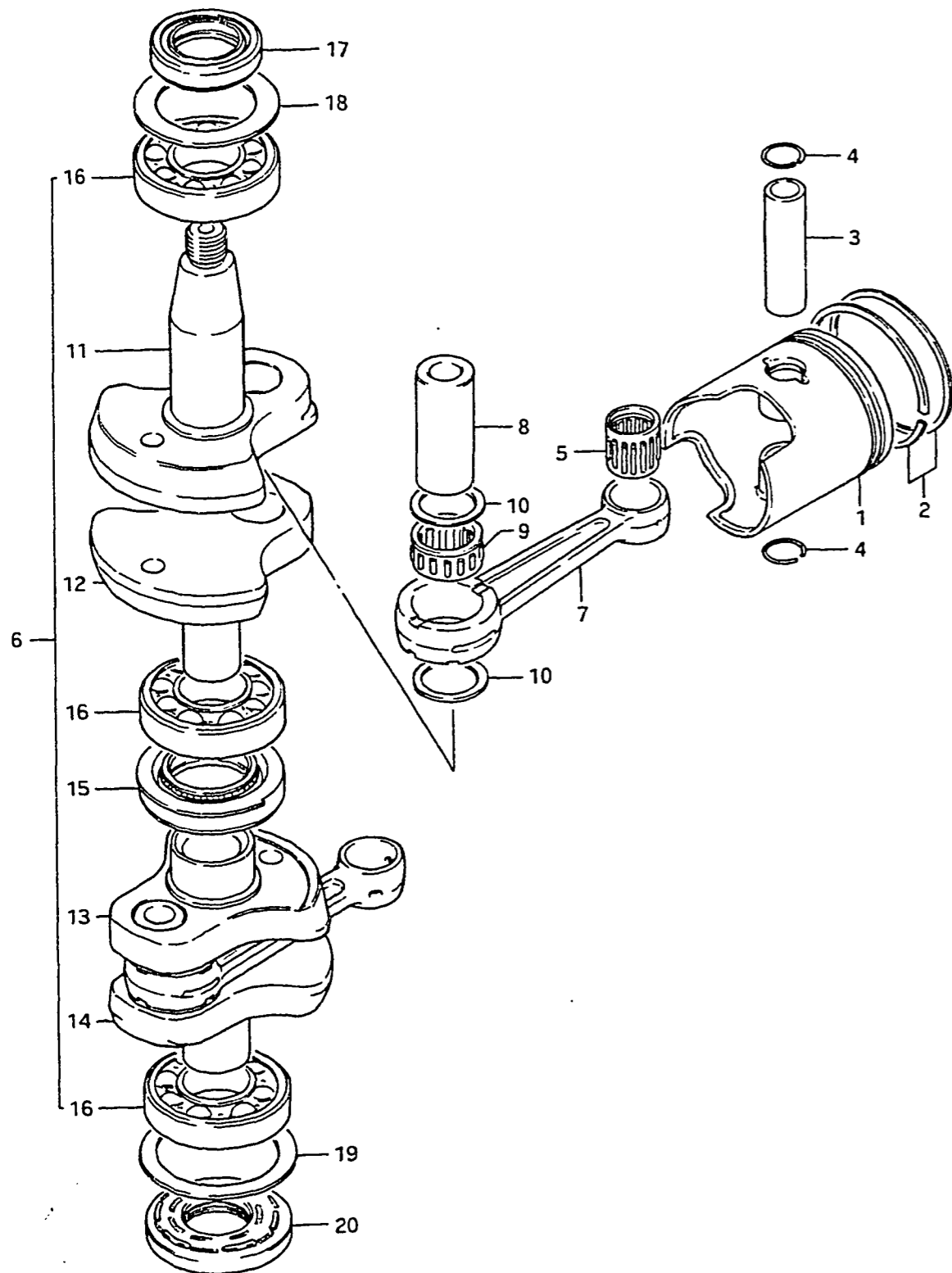

FIG.2 (B- 3) CRANKSHAFT

REF.NO.	PART NO.	DESCRIPTION	Q'TY	REMARKS
1-1	12110-93112	PISTON	2	~412879
1-2	12110-93130	PISTON	2	512880~
1-3	12110-93112-025	PISTON (OS:0.25)	2	OPT,~412879
1-4	12110-93130-025	PISTON (OS:0.25)	2	OPT,512880~
1-5	12110-93112-050	PISTON (OS:0.50)	2	OPT,~412879
1-6	12110-93130-050	PISTON (OS:0.50)	2	OPT,512880~
2-1	12140-93120	RING SET, piston	2	model QD
2-2	12140-93121	RING SET, piston	2	model VE/VF
2-3	12140-93120-025	RING SET, piston (OS:0.25)	2	OPT,model QD
2-4	12140-93121-025	RING SET, piston (OS:0.25)	2	OPT,model VE/VF
2-5	12140-93120-050	RING SET, piston (OS:0.50)	2	OPT,model QD
2-6	12140-93121-050	RING SET, piston (OS:0.50)	2	OPT,model VE/VF
3	12151-93100	PIN, piston	2	
4	09381-14001	SNAP RING	4	
5-1	09263-14014	BEARING (14x18x19.8)	2	~303058
5-2	09263-14019	BEARING (14x18x19.8)	2	303059~
6-1	12200-93902	CRANKSHAFT ASSY	1	~412061
6-2	12200-93903	CRANKSHAFT ASSY	1	412062~
7	12161-93902	.ROD, connecting	2	
8	12211-93900	.PIN, crank	2	
9	09263-20051	.BEARING	2	
10	09160-20052	.THRUST WASHER	4	
11	12221-93901	.CRANKSHAFT, upper	1	
12	12231-93901	.WHEEL, middle upper	1	
13	12232-93900	.WHEEL, middle under	1	
14	12240-93900	.CRANKSHAFT, under	1	
15	09289-30008	.OIL SEAL	1	
16-1	09262-25040	.BEARING (25x52x15)	3	~412061
16-2	09262-25078	.BEARING (25x52x15)	3	412062~
17	09283-25035	OIL SEAL (25x40x7)	1	
18	09160-36003	THRUST WASHER	1	
19	09160-46004	THRUST WASHER	1	
20	09283-25075	OIL SEAL (24x52x7)	1	

FIG.3

3

FIG.3 (B- 4) INLET CASE

Q'TY

REMARKS

REF.NO.	PART NO.	DESCRIPTION	Q'TY	REMARKS
1	13150-93920	REED VALVE ASSY	1	
2-1	12481-93900-02M	CASE, inlet	1	~304868
2-2	12481-93901-02M	CASE, inlet	1	304869~
3	01107-06358	BOLT (6x35)	6	
4	08321-21067	LOCK WASHER	6	
5	13811-93950	CASE, silencer	1	
6	13812-93900	COVER, silencer	1	
7	03242-05169	SCREW	3	
8	13125-93950	GASKET, carburetor	1	
9	12485-93900	PIECE, inlet case	1	
10	01517-06907	BOLT	2	
11	09160-06066	WASHER (6.5x20x1.6)	2	
12	13633-93900	LEVER, chock	1	
13	09148-06008	NUT	1	

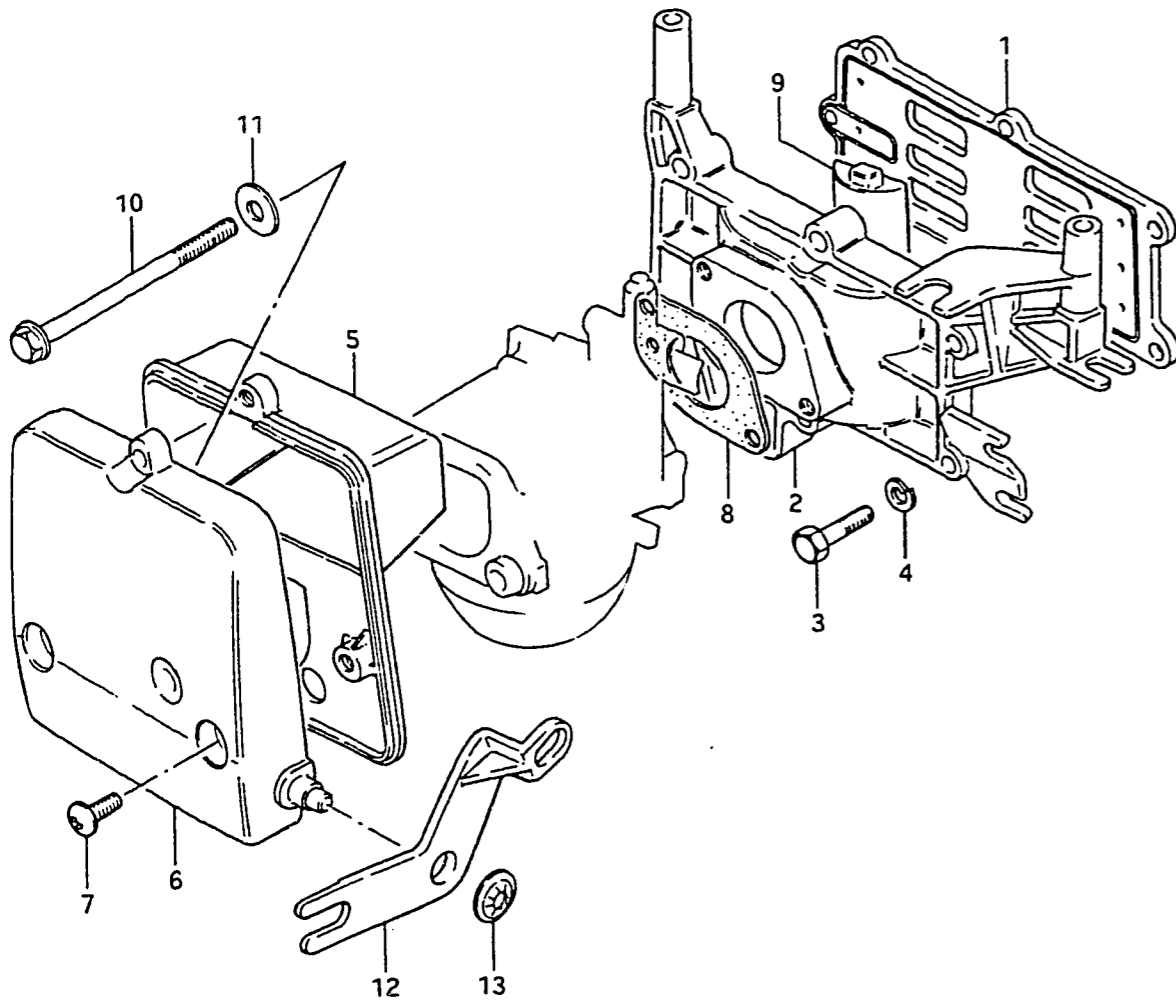

FIG.4

FIG.4 (B- 5) CARBURETOR

REF.NO.	PART NO.	DESCRIPTION	Q'TY	REMARKS
1-1	13200-93911	CARBURETOR ASSY	1	~412879
1-2	13200-93912	CARBURETOR ASSY	1	512880~
2	09492-52002	.JET, pilot, 52.5	1	
3	13267-93900	.SCREW, pilot	1	
4	13268-96110	.SPRING, throttle	2	
5	13254-98100	.PIN, float	1	
6	13250-98110	.FLOAT	1	
7	13371-98100	.NEEDLE	1	
8	13251-98100	.GASKET, float chamber	1	
9	13661-93900	.SCREW, throttle stop	1	
10	13343-98100	.GASKET	1	
11	13613-98100	.BOLT	1	
12	09491-22013	.JET, main, 110	1	
13	15100-93900	.PUMP ASSY, set	1	
14	15170-93900	..DIAPHRAGM SET	1	
15-1	09491-23012	JET, main, 115	1	OPT
15-2	09491-21012	JET, main, 105	1	OPT
15-3	09491-20010	JET, main, 100	1	OPT
16	13631-93900	KNOB, chock lever	1	

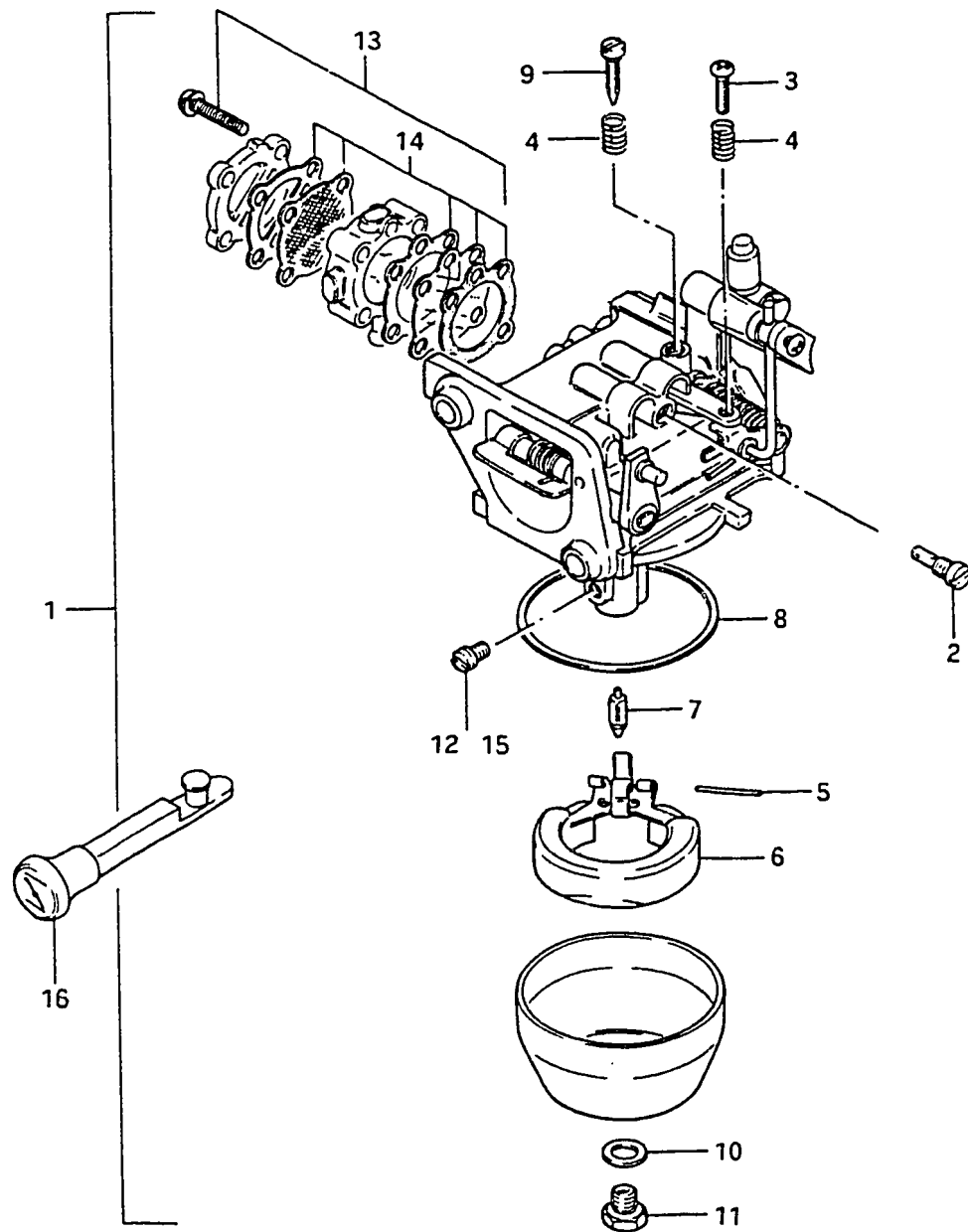

FIG.5

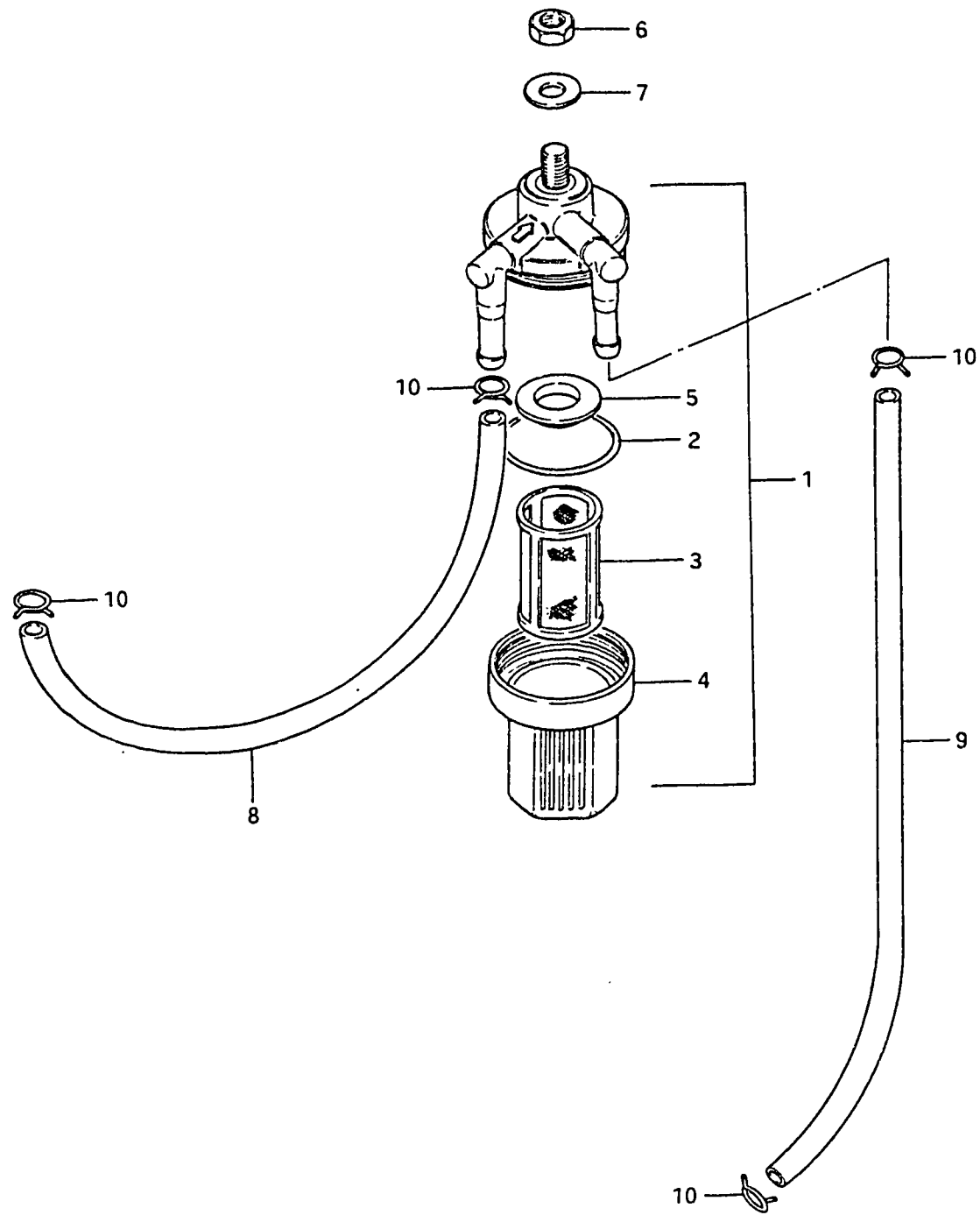

FIG.5 (B- 6) FUEL PUMP

REF.NO.	PART NO.	DESCRIPTION	Q'TY	REMARKS
1	15410-93400	FILTER, fuel	1	
2	15415-93400	.O RING	1	
3	15412-93400	.STRAINER	1	
4	15413-93400	.CUP	1	
5	15416-93400	.PACKING, filter	1	
6	08310-22088	NUT	1	
7	08322-21068	WASHER	1	
8	09343-05137	HOSE (CONN+FILTER)	1	L: 500+127
9	09343-05137	HOSE (FILTER+PUMP)	1	L: 500+270
10	09401-09402	CLIP	4	

FIG.6

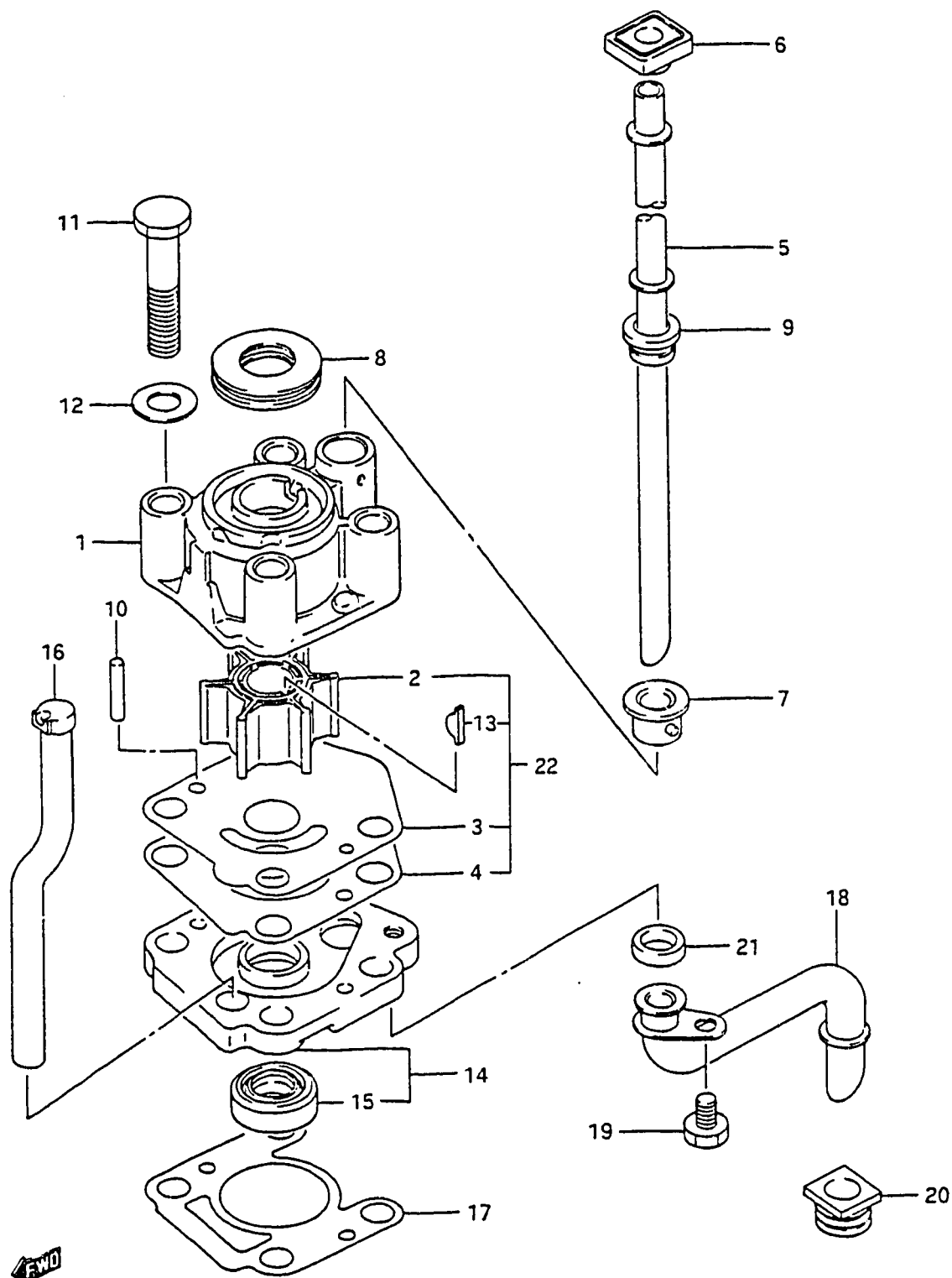

FIG.6 (B- 7) WATER PUMP

REF.NO.	PART NO.	DESCRIPTION	Q'TY	REMARKS
1-1	17411-93900	CASE, water pump	1	~412879
1-2	17411-93901	CASE, water pump	1	512880~
2	17461-93900	IMPELLER, water pump	1	
3-1	17471-93901	PANEL, pump case under	1	~412879
3-2	17471-93902	PANEL, pump case under	1	512880~
4-1	17472-93900	GASKET, case under	1	~412879
4-2	17472-93901	GASKET, case under	1	512880~
5-1	17561-93910	TUBE, water (S)	1	
5-2	17561-93900	TUBE, water (L)	1	
6	17563-93900	RUBBER, water tube upper	1	
7	17564-93900	BUSH, water pump case	1	
8	17417-93900	GROMMET, pump case	1	
9	17562-93900	GROMMET	1	
10	09202-04014	PIN	2	
11	09100-08153	BOLT (8x55)	4	
12	09160-08015	WASHER (8.5x16x1.2)	4	
13-1	09420-03003	KEY	1	~408094
13-2	09420-03005	KEY	1	408095~412879
13-3	17462-93990	KEY	1	512880~
14-1	17450-93900	HOUSING, water inlet	1	~412879
14-2	17450-93910	HOUSING, water inlet	1	512880~
15	09289-12003	.OIL SEAL	1	
16	17453-93900	.DRAIN, water inlet	1	
17-1	17452-93900	GASKET	1	~412879
17-2	17452-93901	GASKET	1	512880~
18	17520-93900	TUBE, water inlet	1	
19	09100-06106	BOLT	1	
20	09308-10010	GROMMET	1	
21	09308-10011	GROMMET	1	
22	17400-93950	KIT, water pump repair	1	OPT



FIG.7

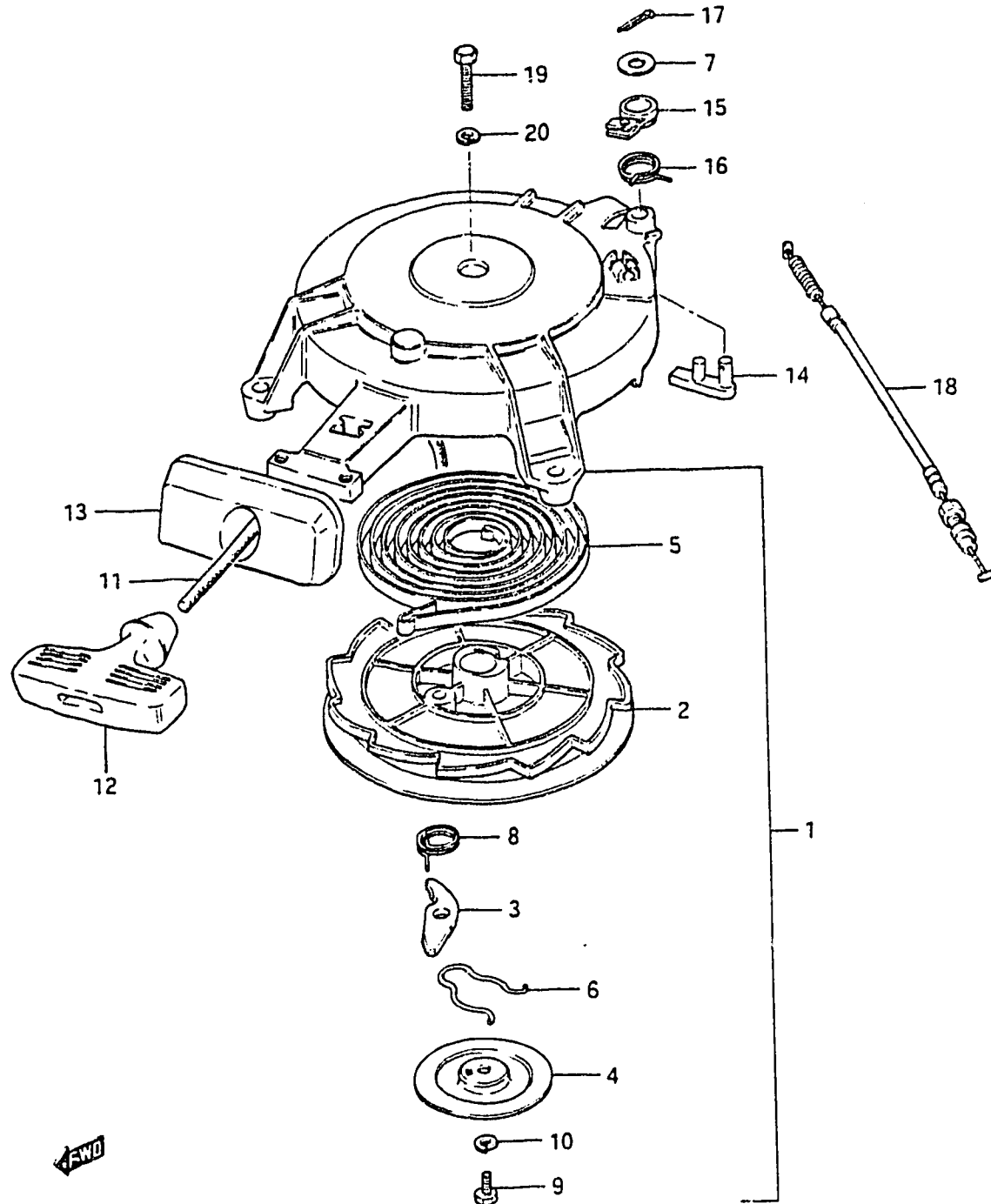

FIG.7 (B- 8) STARTER

REF.NO.	PART NO.	DESCRIPTION	Q'TY	REMARKS
1	18100-93901	STARTER, recoil	1	
2	18120-93900	.DRUM, sheave	1	
3	18131-93900	.PAWL, drive	1	
4	18151-93900	.PLATE	1	
5	18142-93900	.SPRING	1	
6	18153-93900	.SPRING	1	
7	18335-96300	.WASHER	1	
8	18155-88520	.SPRING	1	
9	01107-06168	.BOLT	1	
10	08321-31068	.LOCK WASHER	1	
11	18200-93900	.GRIP ASSY	1	
12	18210-93001	..GRIP	1	
13	18181-93900	.GUIDE, rope	1	
14	18281-96300	.REEL, stopper	1	
15	18282-93900	.ARM, stopper	1	
16	18284-93900	.SPRING	1	
17	18348-96300	.PIN	1	
18	18292-93900	.CABLE NSI (L:315)	1	
19	01517-06308	BOLT	3	
20	08321-21068	LOCK WASHER	3	



FIG. 8

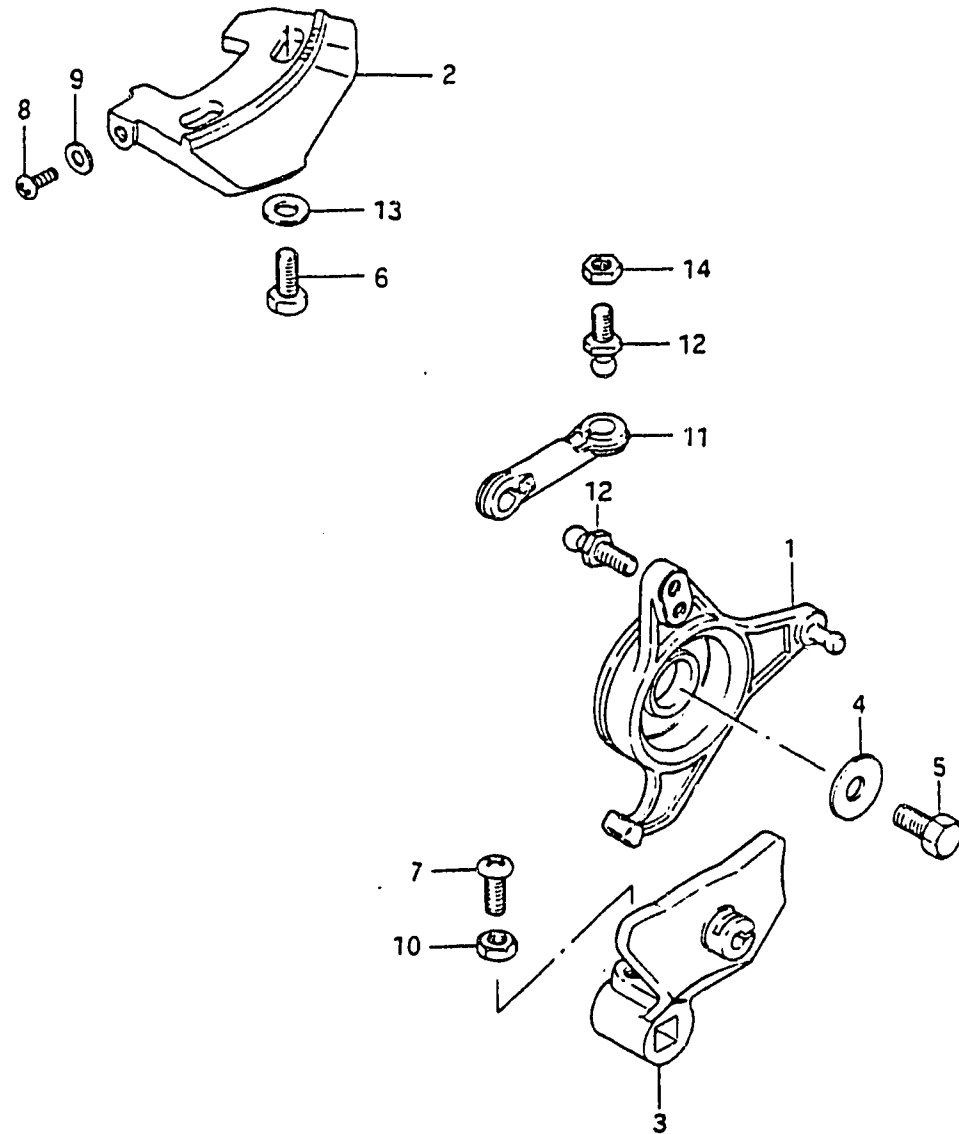

FIG. 8 (B- 9) THROTTLE CONTROL

REF.NO.	PART NO.	DESCRIPTION	Q'TY	REMARKS
1-1	19121-93900	LEVER, throttle	1	~305943
1-2	19121-93901	LEVER, throttle	1	305944~
2	19141-93901	CAM, throttle	1	
3	19811-93900	LIMITER, throttle	1	
4	09160-06046	WASHER (6.5x20x1.5)	1	
5	01107-06128	BOLT	1	
6	01107-05128	BOLT	2	
7	02112-05168	SCREW	1	
8	02112-06208	SCREW	1	
9	08322-21068	WASHER	1	
10	08310-11058	NUT	1	
11-1	19132-94500	CONNECTOR	1	~410065
11-2	19132-94501	CONNECTOR	1	410066~
12	09119-05010	BALL PIVOT	2	
13	08322-21058	WASHER	2	
14	09140-05001	NUT	1	



FIG. 9

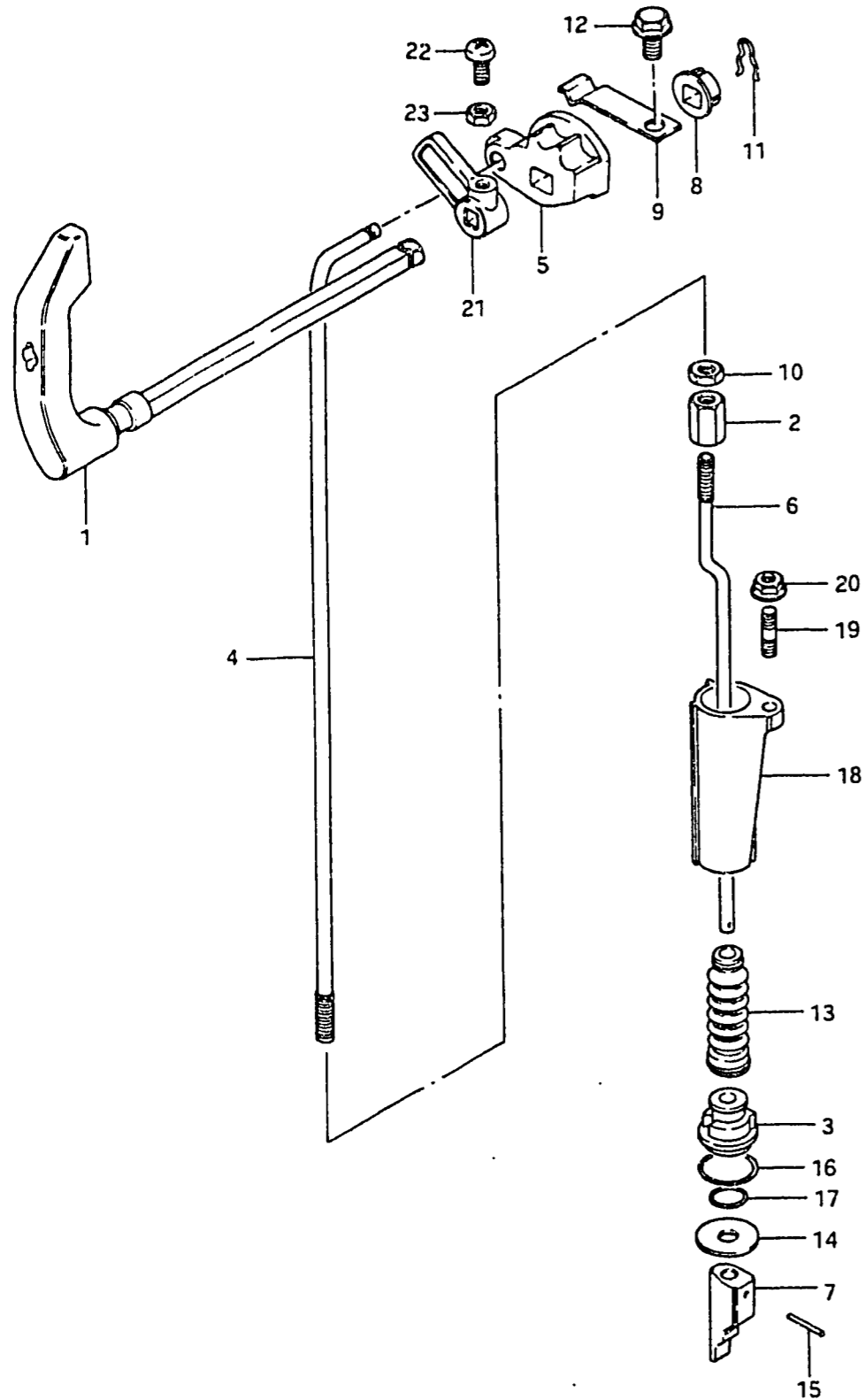
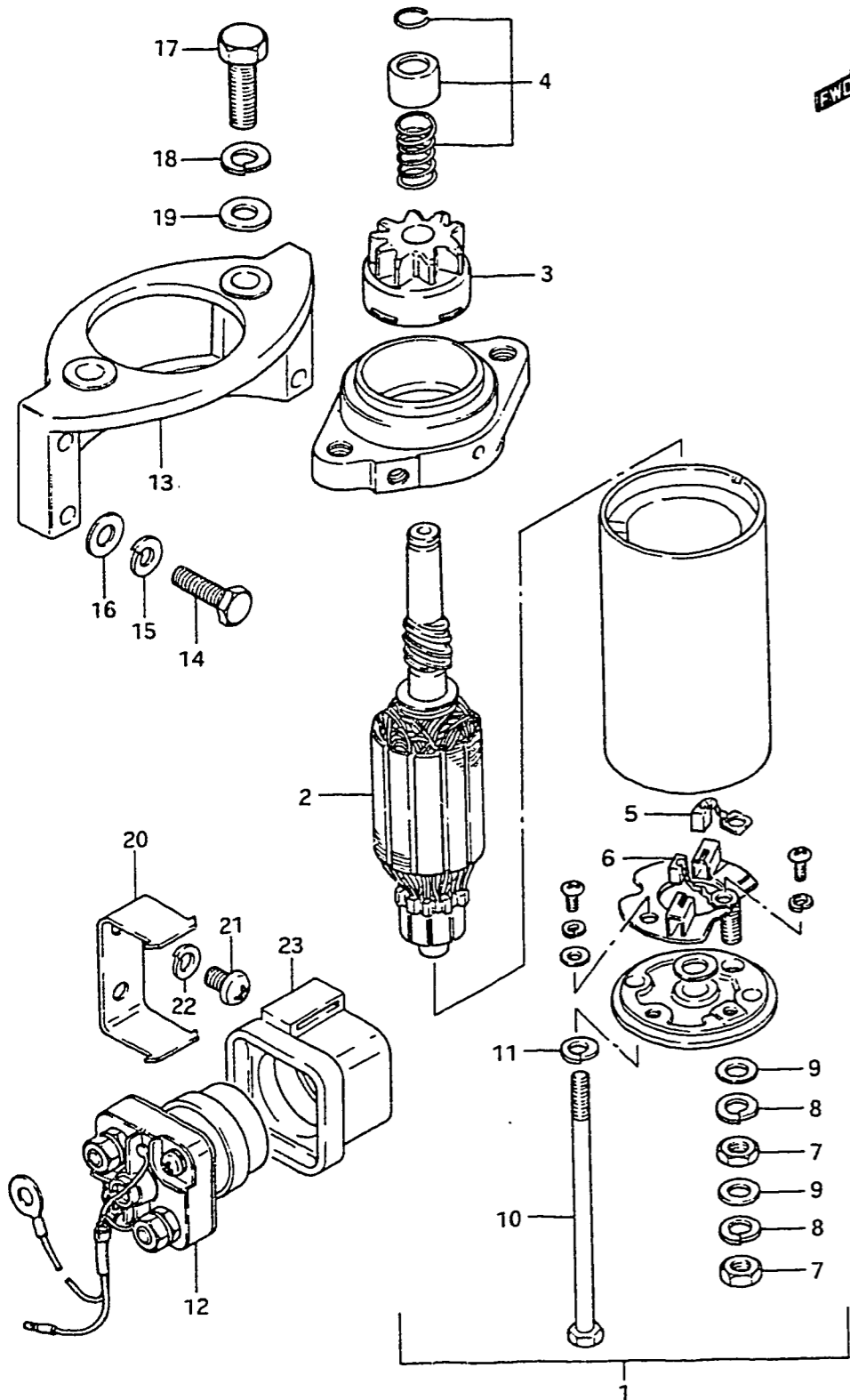

FIG.9 (B-10) CLUTCH

REF.NO.	PART NO.	DESCRIPTION	Q'TY	REMARKS
1-1	21110-93900-02M	LEVER, clutch	1	~412879
1-2	21110-93910	LEVER, clutch	1	512880~
2	23311-94300	TURN BUCKLE, clutch rod	1	
3	25211-93900	GUIDE, shift rod	1	
4-1	23111-93900	ROD, clutch	1	~407291
4-2	23111-93901	ROD, clutch	1	407292~
5	23211-93900	ARM, clutch rod	1	
6-1	25111-93910	ROD, shift (S) L:245	1	
6-2	25111-93900	ROD, shift (L) L:372	1	
7	25311-93900	CAM, shift	1	
8	21220-93900	BUSH, clutch lever	1	
9	23213-93900	SPRING, notch plate	1	
10	09140-06004	NUT	1	
11	09384-06003	SNAP RETAINER	1	
12	01517-06128	BOLT	1	
13-1	25222-93900	BOOT, shift rod	1	~412879
13-2	25222-93901	BOOT, shift rod	1	512880~
14	09160-05005	WASHER (5.5x24x1.6)	1	
15	09205-02006	SPRING PIN	2	
16	09280-05005	O RING	1	
17	09280-19006	O RING	1	
18-1	25205-93900	COLLAR, shift rod	1	~412879
18-2	25205-93901	COLLAR, shift rod	1	512880~
19	09108-05007	STUD BOLT	1	
20	09159-05015	NUT	1	
21	21313-93900	ARM, electrical NS1	1	
22	02112-05168	SCREW	1	
23	08310-11058	NUT	1	

FIG.10



10

FIG.10 (C- 2) STARTING MOTOR

REF.NO.	PART NO.	DESCRIPTION	Q'TY	REMARKS
1	31100-93531	MOTOR ASSY, starting	1	
2	31311-93530	.ARMATURE, starter	1	
3	31320-93530	.PINION ASSY	1	
4	31312-93530	.STOPPER SET, pinion	1	
5	31131-93530	.BRUSH, (+)	1	
6	31132-93530	.BRUSH, (-)	1	
7	08310-22068	.NUT	2	
8	08321-21068	.LOCK WASHER	2	
9	08322-21068	.WASHER	2	
10	31281-93530	.BOLT, starter housing	2	
11	08321-21058	.LOCK WASHER	2	
12-1	31800-95510	RELAY, starter	1	model QD
12-2	31800-94400	RELAY, starter	1	model VE/VF
13	31911-93902-02M	BRACKET, starter	1	
14	01107-06258	BOLT	4	
15	08321-21068	LOCK WASHER	4	
16	08322-11068	WASHER	4	
17	01107-08258	BOLT	2	
18	08321-21088	LOCK WASHER	2	
19	08322-11088	WASHER	2	
20-1	31805-95500	BRACKET, motor relay	1	~407239
20-2	31805-95501	BRACKET, motor relay	1	407240~
21	02112-05088	SCREW	2	
22	08321-21058	LOCK WASHER	2	
23	38422-94510	DAMPER, starter relay	1	

FIG. 11

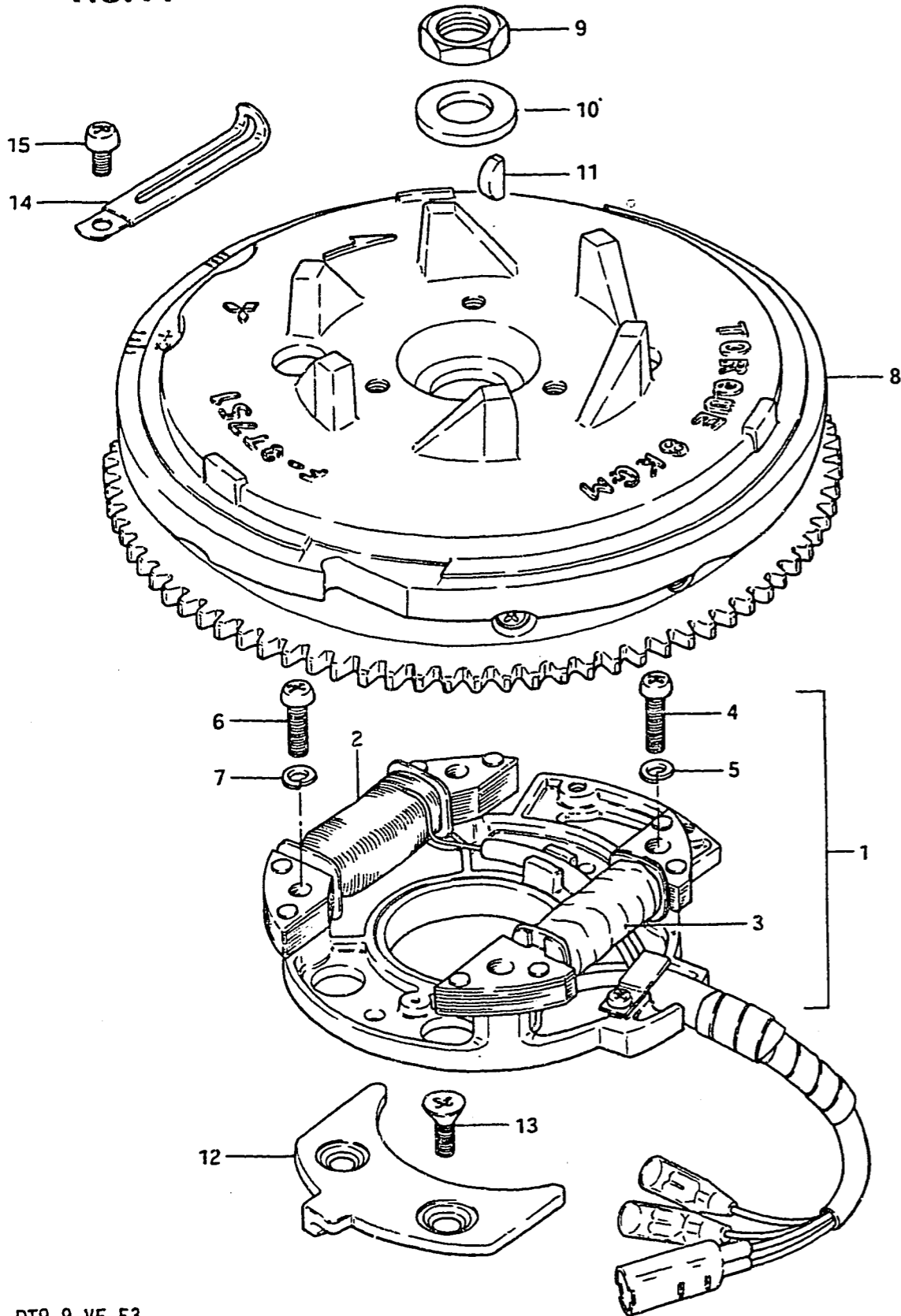

11

FIG. 11 (C- 3) MAGNETO

REF.NO.	PART NO.	DESCRIPTION	Q'TY	REMARKS
1	32101-93911	STARTER ASSY	1	
2-1	32120-93900	.COIL, lighting	1	~409587
2-2	32120-93901	.COIL, lighting	1	409588~
3	32140-93900	.COIL, ignition primary	1	
4	02112-06258	.SCREW	2	
5	08321-21068	.LOCK WASHER	2	
6	02112-04068	.SCREW	2	
7	08321-21048	.LOCK WASHER	2	
8	32102-93912	FLYWHEEL	1	
9	09140-14008	NUT	1	
10	09160-14029	WASHER	1	
11	08341-31049	KEY	1	
12	32390-93900	RETAINER, magneto stator	2	
13	02122-06168	SCREW	4	
14	09404-06404	CLAMP	1	
15	02112-06128	SCREW	1	

FIG.12

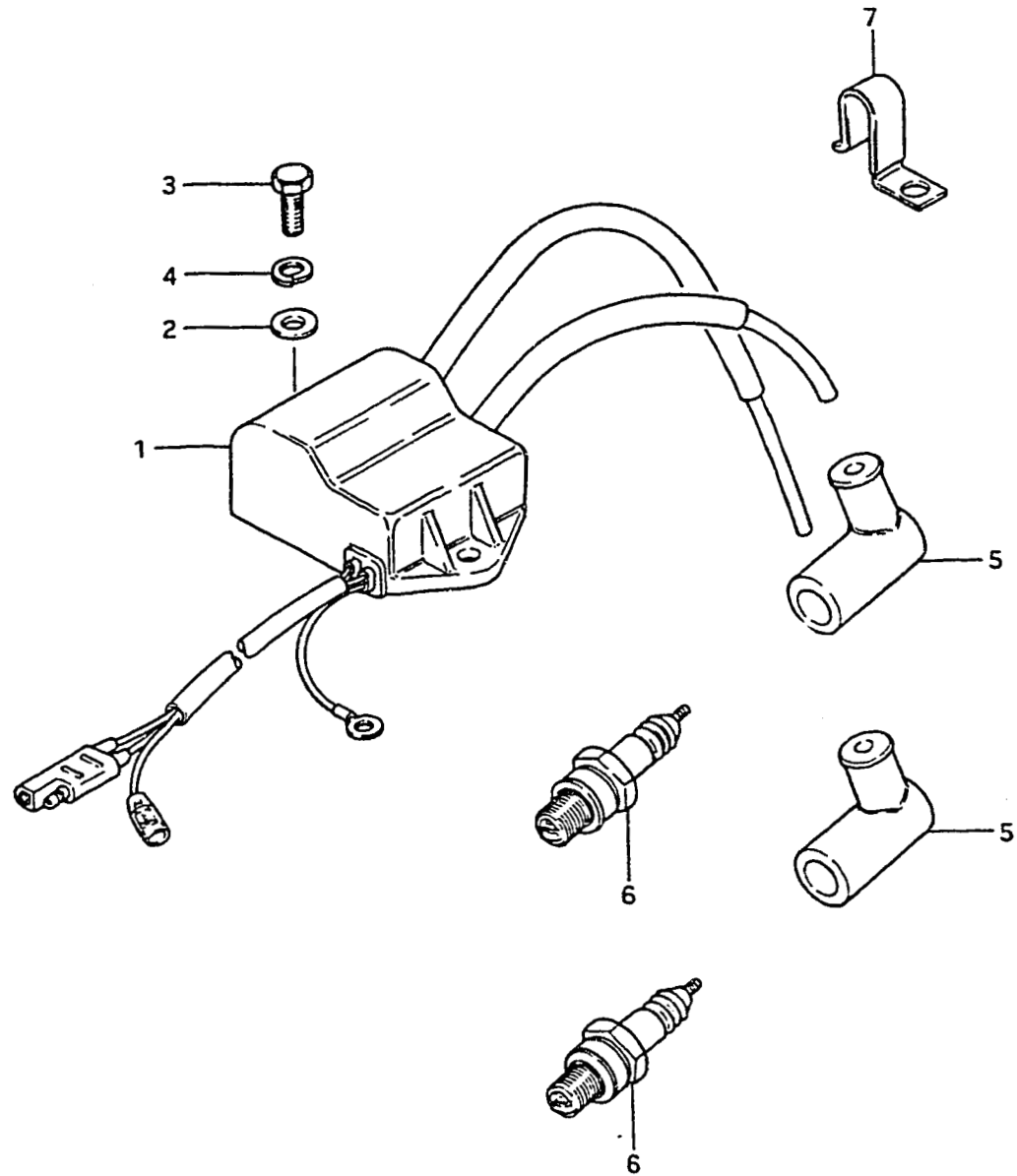
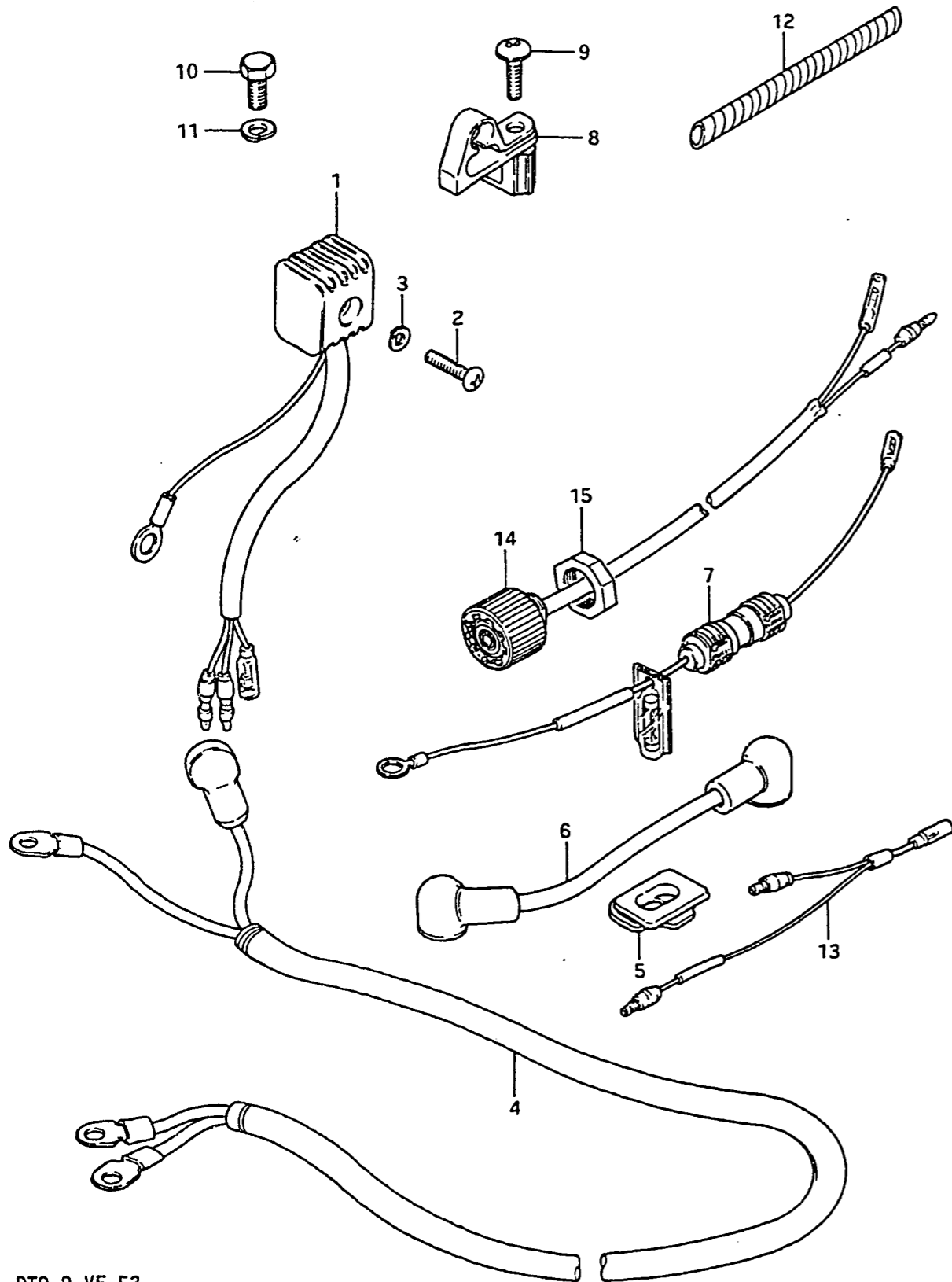

FIG.12 (C- 4) IGNITION

REF.NO.	PART NO.	DESCRIPTION	Q'TY	REMARKS
1	32900-93900	CDI UNIT	1	
2	08322-21067	WASHER	2	
3	01107-06208	BOLT	2	
4	08321-21067	LOCK WASHER	2	
5	33510-95510	CAP, spark plug	2	
6-1	09482-00277	SPARK PLUG, BR7HS	2	~412879
6-2	09482-00269	SPARK PLUG, BP6HS	2	512880~
7	09403-11307	CLAMP	1	

FIG. 13



DT9.9 VF E3

13

FIG.13 (C- 5) ELECTRICAL (1)

REF.NO.	PART NO.	DESCRIPTION	Q'TY	REMARKS
1	32800-95720	RECTIFIER ASSY	1	
2	02112-05257	SCREW	1	
3	08321-21057	LOCK WASHER	1	
4	33810-93900	CABLE ASSY, starter	1	
5	33811-96300	GROMMET, starter cable	1	
6	33820-93900	CABLE ASSY, positive terminal	1	
7	36740-93900	CASE ASSY, fuse	1	
8	33816-96300	CLAMP, two cable	1	
9	03242-06259	SCREW	1	
10	01107-06168	BOLT	1	
11	08321-21067	LOCK WASHER	1	
12	33833-95500	TUBE, trim relay cable	1	
13	36610-93901	WIRE HARNESS, ME	1	
14	37160-93910	SWITCH ASSY, start	1	
15	37861-95200	.NUT, trim switch	1	

DT9.9 VF E3

C5

FIG.14

FIG.14 (C- 6) ELECTRICAL (2)

Q'TY

REMARKS

REF.NO.	PART NO.	DESCRIPTION	Q'TY	REMARKS
1-1	37721-93900	SWITCH ASSY, neutral	1	~411726
1-2	37721-93901	SWITCH ASSY, neutral	1	411727~
2	37725-94301	ACTUATOR, neutral switch	1	
3	37726-93901	BRACKET, neutral switch	1	
4	09100-06018	BOLT (6x12)	1	
5	09160-06015	WASHER (6.5x13x1)	1	
6	09162-06001	LOCK WASHER	1	
7-1	37800-93902	SWITCH ASSY, stop	1	~412638
7-2	37800-93950	SWITCH ASSY, stop	1	412639~
8	09100-06018	BOLT (6x12)	1	
9	09160-06015	WASHER (6.5x13x1)	1	
10	09162-06001	LOCK WASHER	1	

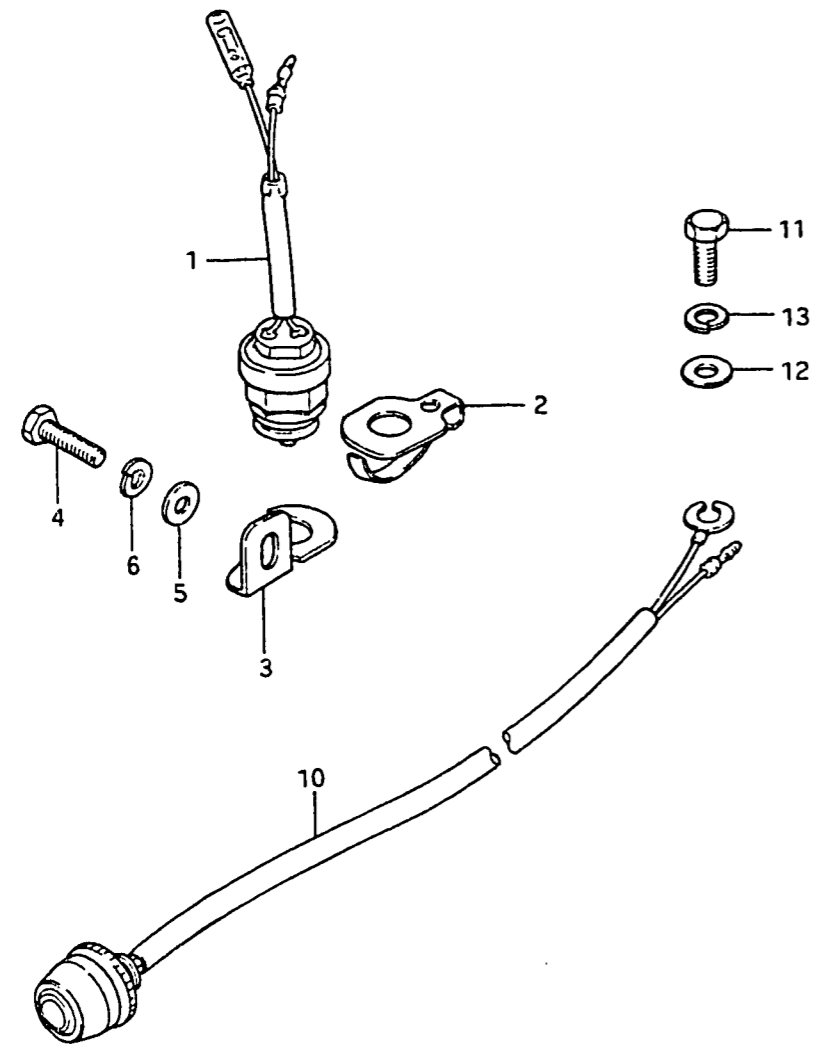



FIG. 15

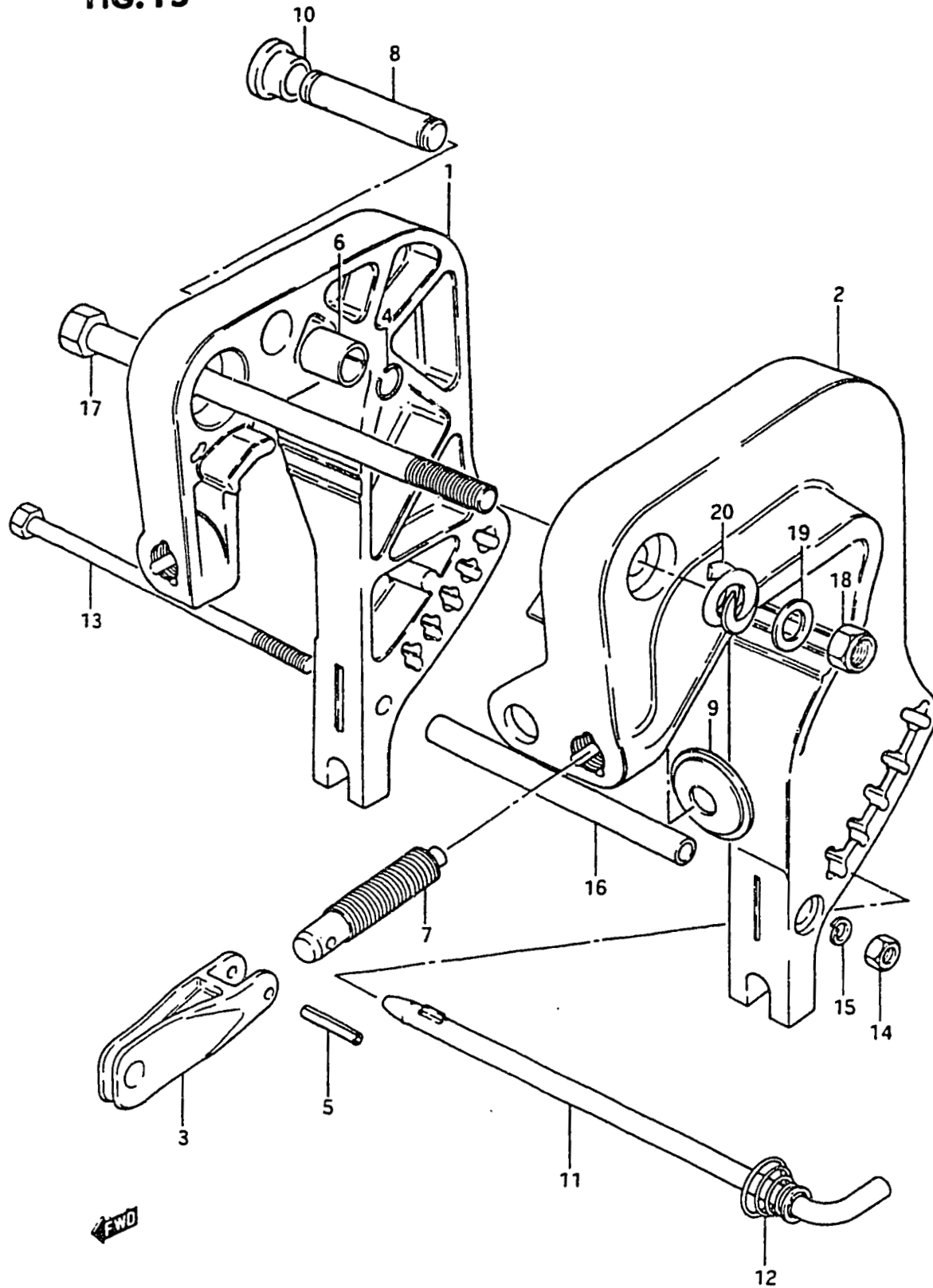

FIG.15 (C- 7) CLAMP BRACKET

REF.NO.	PART NO.	DESCRIPTION	Q'TY	REMARKS .
1-1	41111-93901-02M	BRACKET, clamp STBD	1	~406886
1-2	41111-93902-02M	BRACKET, clamp STBD	1	406887~
2-1	41121-93901-02M	BRACKET, clamp PORT	1	~407193
2-2	41121-93902-02M	BRACKET, clamp PORT	1	407194~
3	41212-93000-02M	HANDLE, clamp	2	
4	09380-11007	SNAP RING	1	
5	09205-06012	SPRING PIN	2	
6	09303-14003	BUSH	1	
7-1	41211-93910	SCREW, clamp	2	L:78
7-2	41211-93002	SCREW, clamp	2	OPT,L:78
7-3	41211-93702	SCREW, clamp	2	OPT,L:90
7-4	41211-93712	SCREW, clamp	2	OPT,L:68
8	41222-93910	PIN, tilt stopper	1	
9	41213-98100	PLATE, clamp	2	
10	41221-96300	KNOB, tilt stopper	1	
11	45420-93900	PIN, tilt lock	1	
12	09441-17001	.SPRING	1	
13	09100-06105	BOLT	1	
14	09140-06020	NUT	1	
15	09162-06006	LOCK WASHER	1	
16	09180-06113	SPACER	1	
17	09100-10199	BOLT	1	
18	09159-10050	NUT	1	
19	09160-10082	WASHER	1	
20	09440-22006	SPRING	1	

FIG. 16

FIG.16 (C- 8) SWIVEL BRACKET

Q'TY

REMARKS

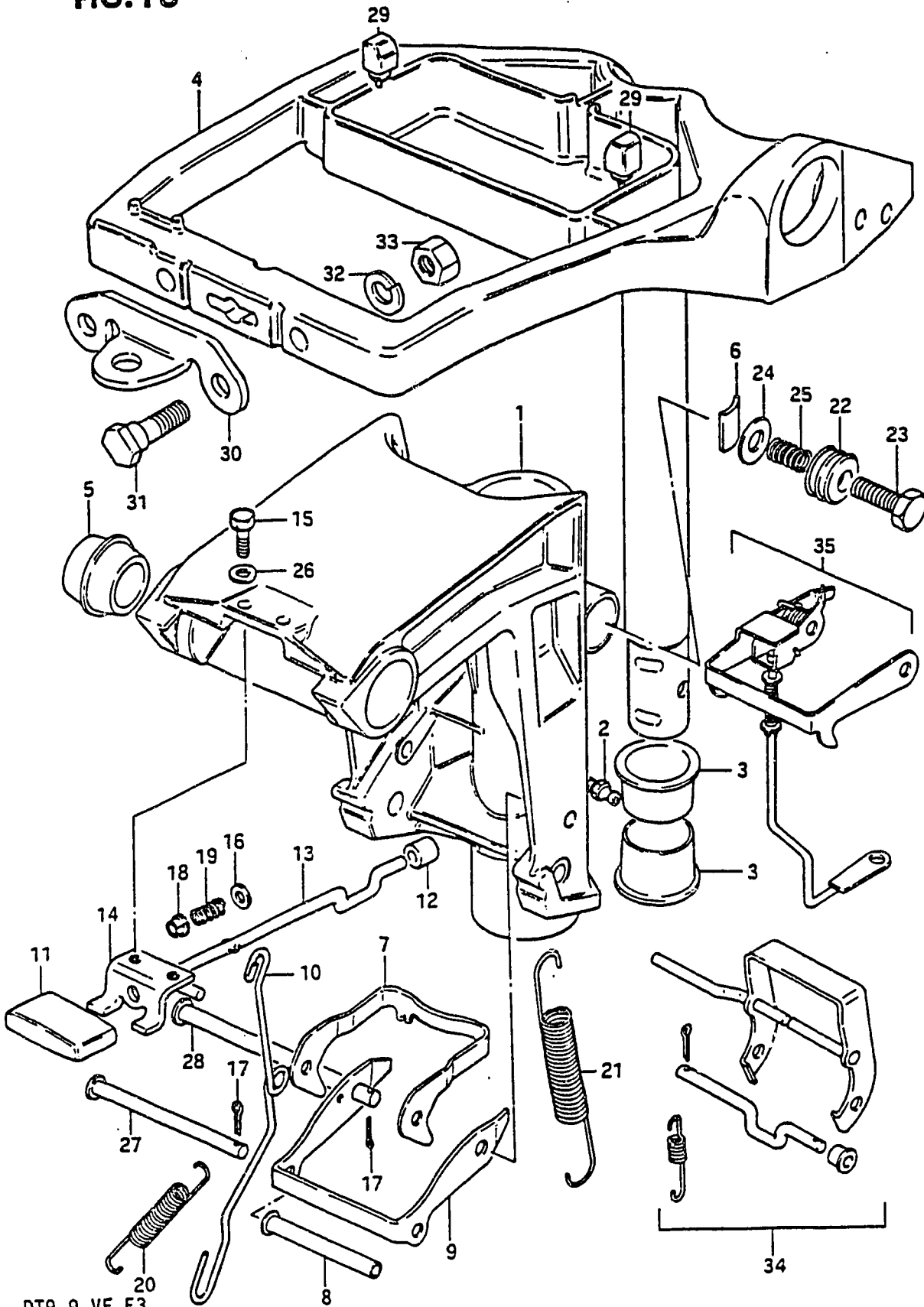

REF.NO.	PART NO.	DESCRIPTION	Q'TY	REMARKS
1-1	43111-93901-02M	BRACKET, swivel	1	~410862
1-2	43111-93902-02M	BRACKET, swivel	1	410863~
2	22511-99000	NIPPLE, grease	1	
3	43711-93900	BUSH, steering	2	
4-1	43750-93901-02M	BRACKET, steering	1	~408743
4-2	43750-93902-02M	BRACKET, steering	1	408744~
5	09306-10012	BUSH	2	
6	43411-93900	ADJUSTER, steering	1	
7-1	45231-93901	ARM, reverse lock	1	~408743
7-2	45231-93902	ARM, reverse lock	1	408744~
8-1	45246-93900	SPACER, reverse lock arm	1	~408743
8-2	45246-93901	SPACER, reverse lock arm	1	408744~
9	45241-93901	LINK, reverse lock arm	1	
10	45252-93901	LINK, release lever	1	
11	45255-96300	KNOB, release lever	1	
12	45257-93900	BUSH, release lever	1	
13	45260-96300	LEVER, release	1	
14	45311-93900-02M	BRACKET, release lever	1	
15	09100-05011	BOLT (5x12)	2	
16	09160-04012	WASHER (4.2x10x1)	1	
17	09204-01001	COTTER PIN	2	
18	09319-04001	BUSH	1	
19	09440-04021	SPRING	1	
20	09443-05013	SPRING	1	

FIG. 16

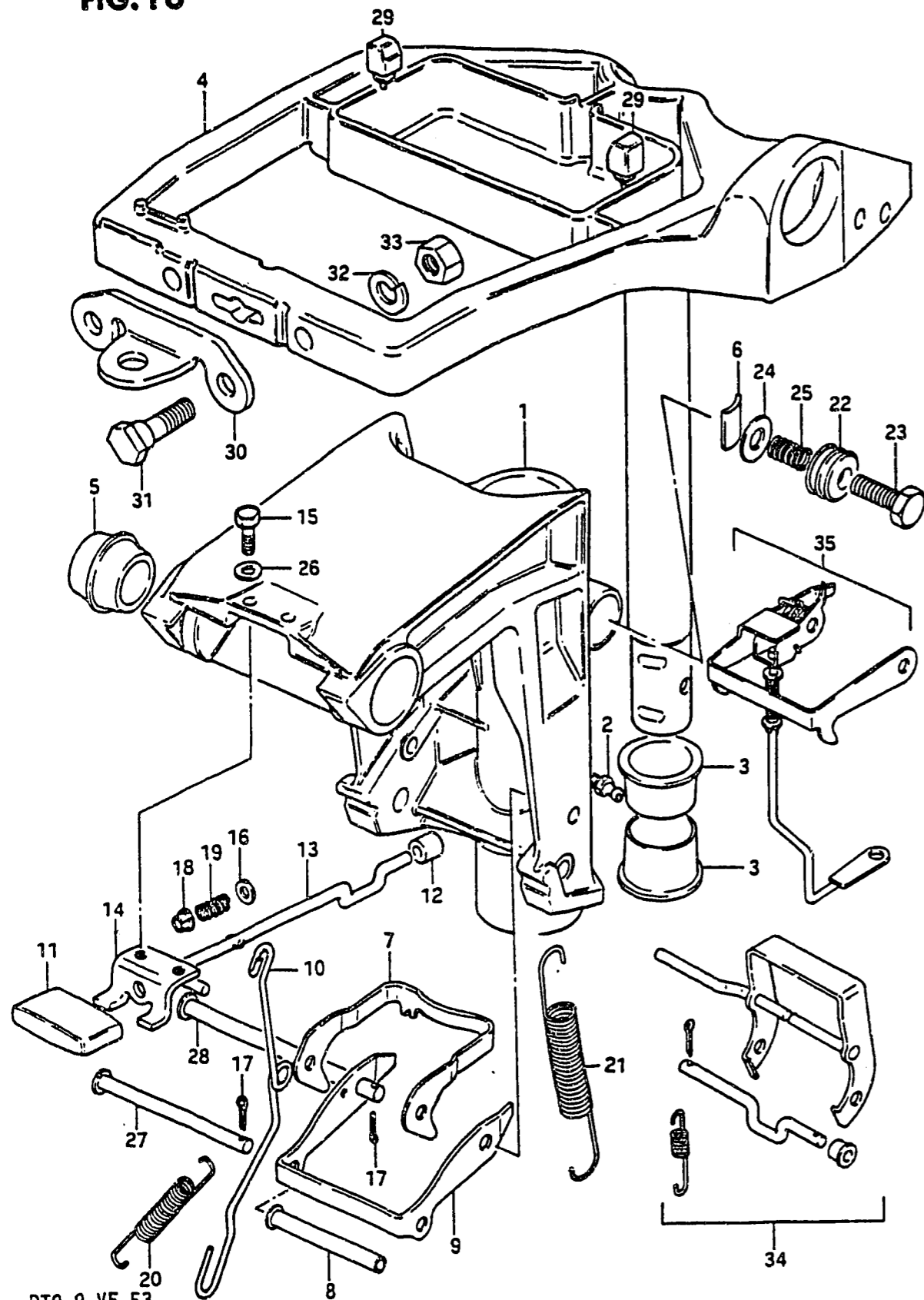

DT9.9 VF E3

Revised 1/23/85

FIG.16 (C- 9) SWIVEL BRACKET

REF.NO.	PART NO.	DESCRIPTION	Q'TY	REMARKS
21	09443-11014	SPRING	2	
22	43412-93900	COVER, adjuster	1	
23-1	09100-08219	BOLT	1	~410862
23-2	09100-08232	BOLT	1	410863~
24	09160-08015	WASHER (8.5x16x1.2)	1	
25	09440-11019	SPRING	1	
26	09160-05010	WASHER (5.5x10x0.8)	2	
27	09200-05014	PIN	1	
28-1	09200-06042	PIN	1	~408743
28-2	09200-06051	PIN	1	408744~
29	43765-93900	CUSHION	2	
30	43755-93900	ATTCHMENT, bracket	1	OPT
31	09100-08224	BOLT (8x35)	2	OPT
32	09162-08003	LOCK WASHER	2	OPT
33	09140-08016	NUT	2	OPT
34	45700-93900	SHALLOW DRIVE ASSY	1	
35	45200-93900	REVERSE LOCK SET	1	OPT

DT9.9 VF E3

Revised 1/23/85

FIG.17

FIG.17 (D- 2) EXHAUST TUBE

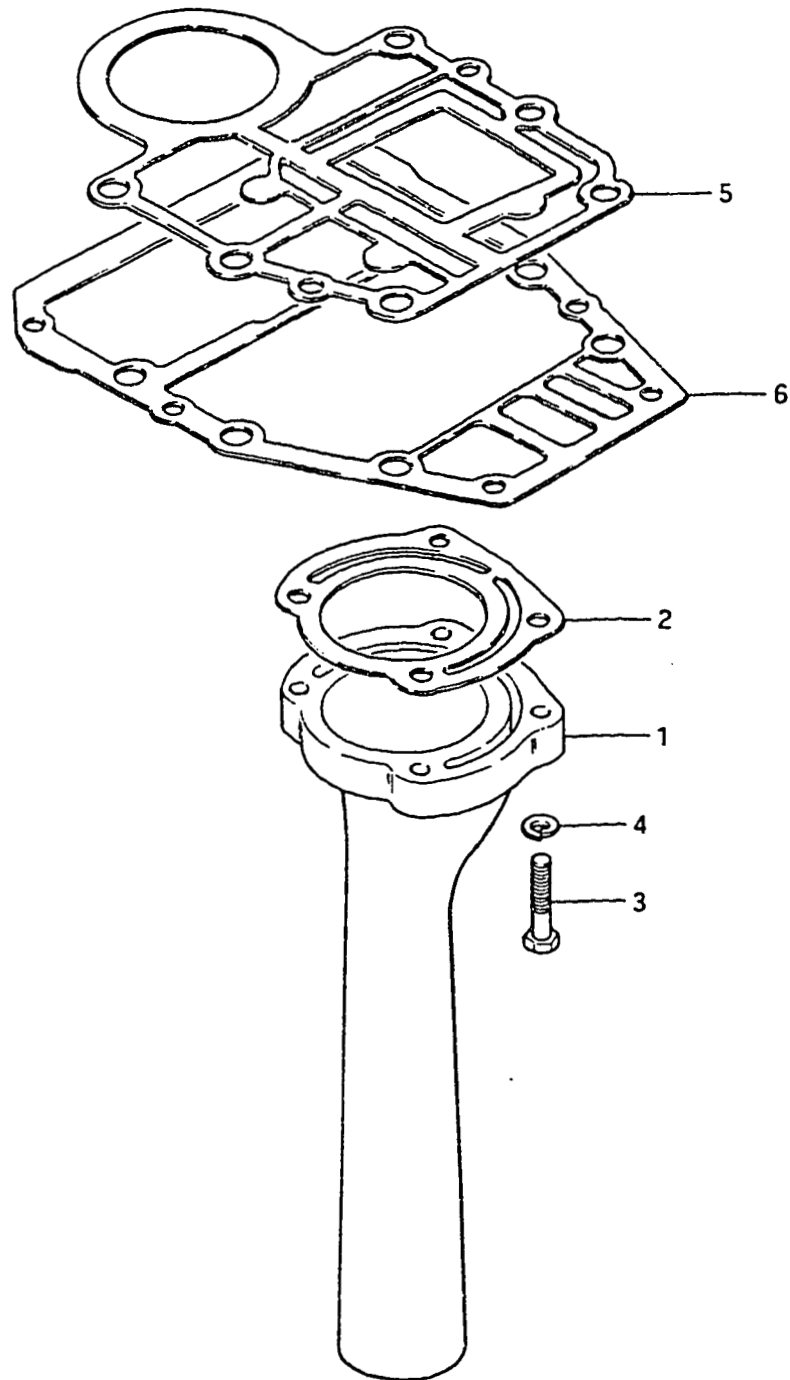

REF.NO.	PART NO.	DESCRIPTION	Q'TY	REMARKS
1	14211-93900	TUBE, exhaust	1	
2	14213-93900	GASKET, exhaust tube	1	
3	09100-06121	BOLT (6x30)	4	
4	09162-06006	LOCK WASHER	4	
5	11433-93901	GASKET, under oil seal	1	
6	52113-93901	GASKET, drive shaft	1	

FIG.18

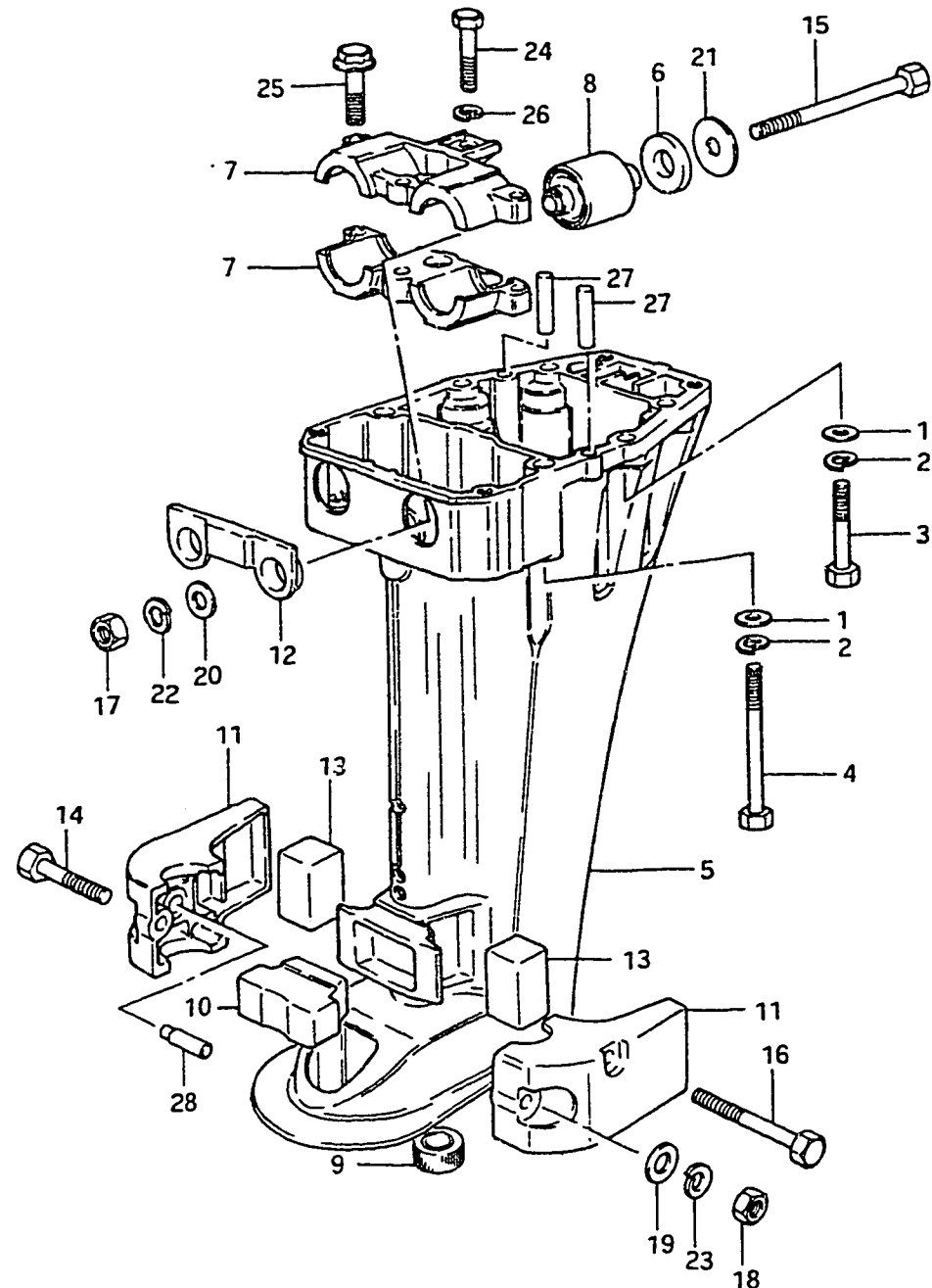

FIG.18 (D- 3) DRIVESHAFT HOUSING

REF.NO.	PART NO.	DESCRIPTION	Q'TY	REMARKS
1	09160-06015	WASHER (6.5x13x1)	6	
2	09162-08007	LOCK WASHER	6	
3	09100-08214	BOLT (8x50)	4	
4	09100-08197	BOLT (8x85)	2	
5-1	52111-93911-02M	HOUSING, drive shaft (S)	1	~408743
5-2	52111-93912-02M	HOUSING, drive shaft (S)	1	408744~
5-3	52111-93901-02M	HOUSING, drive shaft (L)	1	~409173
5-4	52111-93902-02M	HOUSING, drive shaft (L)	1	409174~
6	54121-93900	CUSHION, upper mount	2	
7	54137-93901	COVER, upper mounting	2	
8-1	54130-93900	MOUNT, upper	2	model QD
8-2	54130-93901	MOUNT, upper	2	model VE/VF
9	09307-13001	BUSH	1	
10	54151-93900	MOUNT, lower thrust	1	
11	54210-93900-02M	COVER, lower mounting	1	
12	54125-93900	MOUNT, upper thrust reverse	1	
13	54167-93900	MOUNT, lower side	2	
14	09100-08220	BOLT	1	
15	09100-08209	BOLT	2	
16	09100-08210	BOLT	2	
17	09140-08016	NUT	2	
18	09140-08016	NUT	1	
19	09160-08082	WASHER (8.5x16x1.2)	3	
20	09160-08084	WASHER	2	
21	09160-08083	WASHER	2	
22	09162-08007	LOCK WASHER	2	
23	09162-08007	LOCK WASHER	3	
24	09100-06112	BOLT	1	
25	09103-08111	BOLT	2	
26	09162-06006	LOCK WASHER	1	
27	09202-06019	KNOCK PIN	2	
28	54213-93900	PIN	2	



FIG. 19

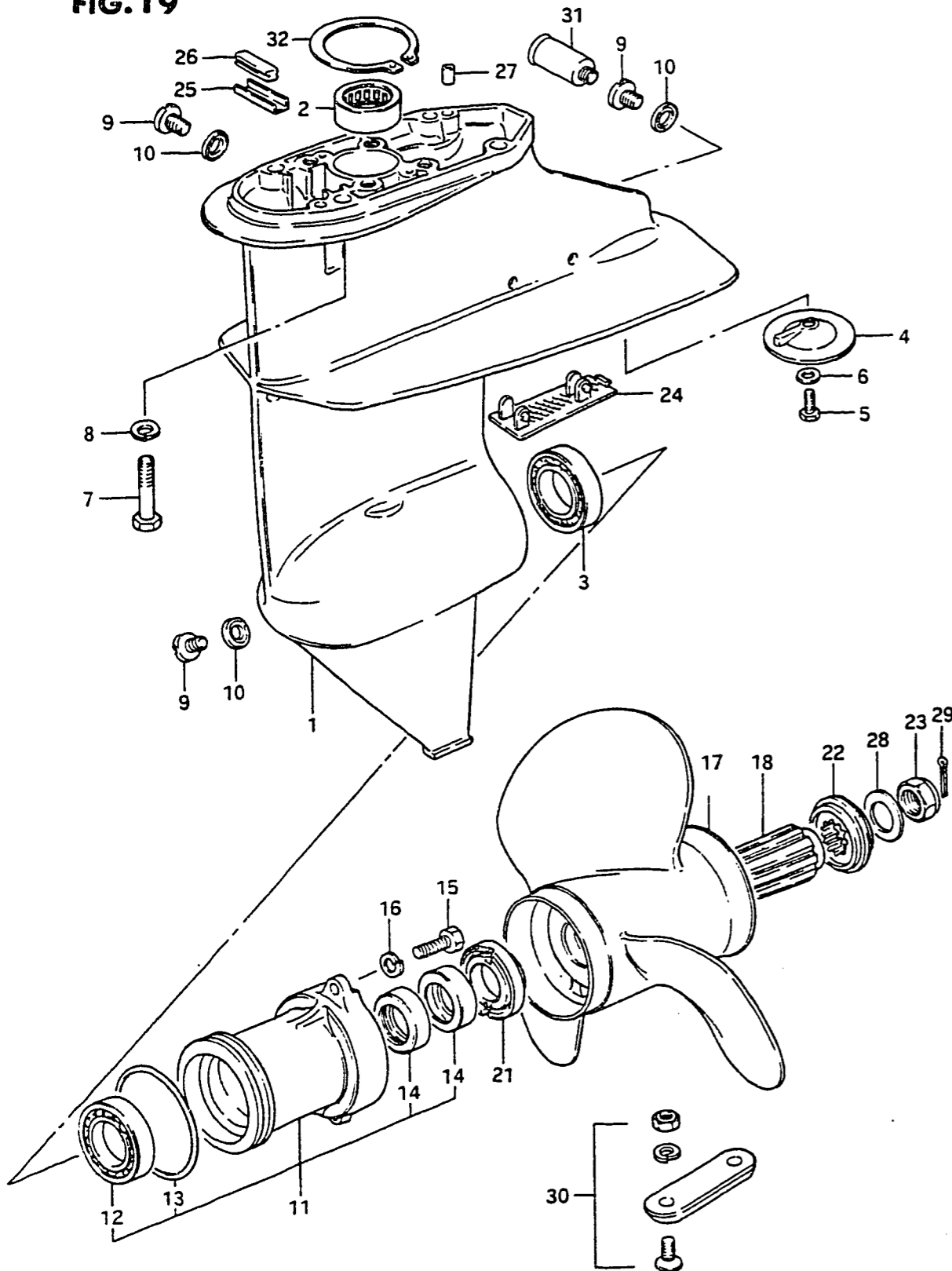
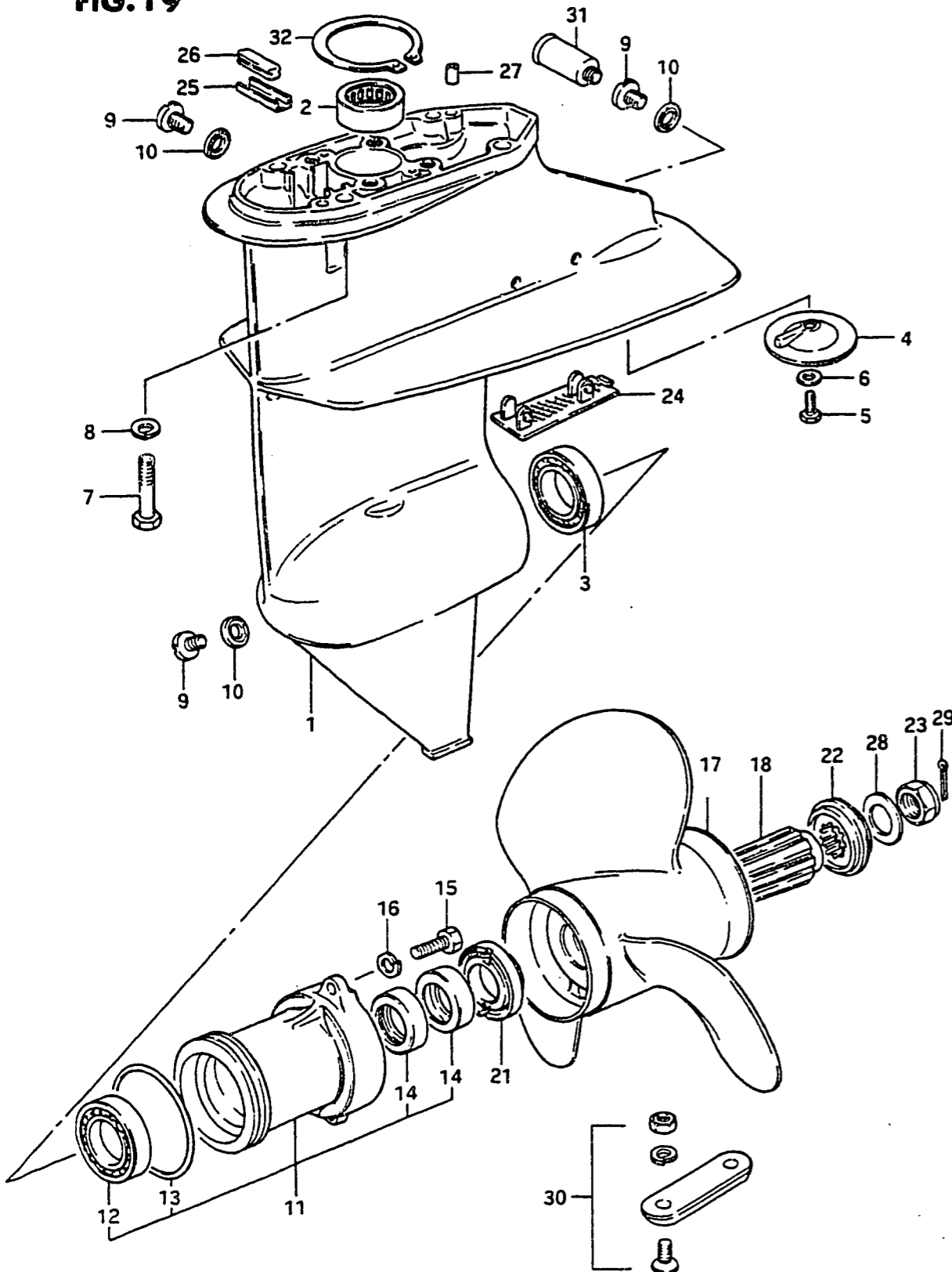

FIG.19 (D- 4) GEAR CASE

REF.NO.	PART NO.	DESCRIPTION	Q'TY	REMARKS
1	55100-93900-02M	CASE, gear	1	
2	09263-15019	.BEARING (15x21x12)	2	
3	08113-62057	.BEARING	1	
4	55321-93900	.ZINC, protection	1	
5	09100-06115	.BOLT (6x15)	1	
6	09160-06015	.WASHER (6.5x13x1)	1	
7	09100-08168	BOLT (8x30)	4	
8	09162-08003	LOCK WASHER	4	
9-1	09248-10004	PLUG	3	406190
9-2	09248-10005	PLUG	3	406191~
10	09168-10022	GASKET (10x17x1.5)	3	
11	56120-93900-02M	HOUSING, propeller shaft	1	
12	08110-60050	.BEARING	1	
13	09280-57002	.O RING	1	
14	09289-17006	OIL SEAL (16x30x6)	2	
15	09100-06103	BOLT (6x20)	2	
16	09162-06001	LOCK WASHER	2	
17-1	58110-93900-01T	PROPELLER, 3x9 1/4x7	1	M700
17-2	58110-93910-01T	PROPELLER, 3x9 1/4x8	1	M800
17-3	58110-93931-01T	PROPELLER, 3x9 1/4x10	1	M1000,L TYPE:STD
17-4	58110-93920-01T	PROPELLER, 3x9 1/4x9	1	M900
17-5	58110-93941-01T	PROPELLER, 3x9 1/4x11	1	M1100,S TYPE:STD
18	58120-93901	BUSH, propeller	1	

NOTE: Ref. No. 19 and 20 have been deleted.

FIG. 19



21

FIG.19 (D- 5) GEAR CASE

REF.NO.	PART NO.	DESCRIPTION	Q'TY	REMARKS
21	57632-93900	STOPPER, propeller bush	1	
22	57633-93900	SPACER, propeller nut	1	
23	09159-12014	NUT	1	
24-1	17631-93900	FILTER, water	1	~412879
24-2	17631-93901	FILTER, water	1	512880~
25	55331-93901	CORE, exhaust seal	1	
26	55332-93900	RUBBER, exhaust seal	1	
27	09202-06023	KNOCK PIN	2	
28	09160-12066	WASHER (12.5x22x2.5)	1	
29	09204-02004	COTTER PIN	1	
30	55300-95500	ZINC, protection	1	OPT
31	55181-95200	ATTACHMENT, flush hose	1	
32	08331-21329	CIRCLIP	1	

FIG. 20 (D- 6) TRANSMISSION

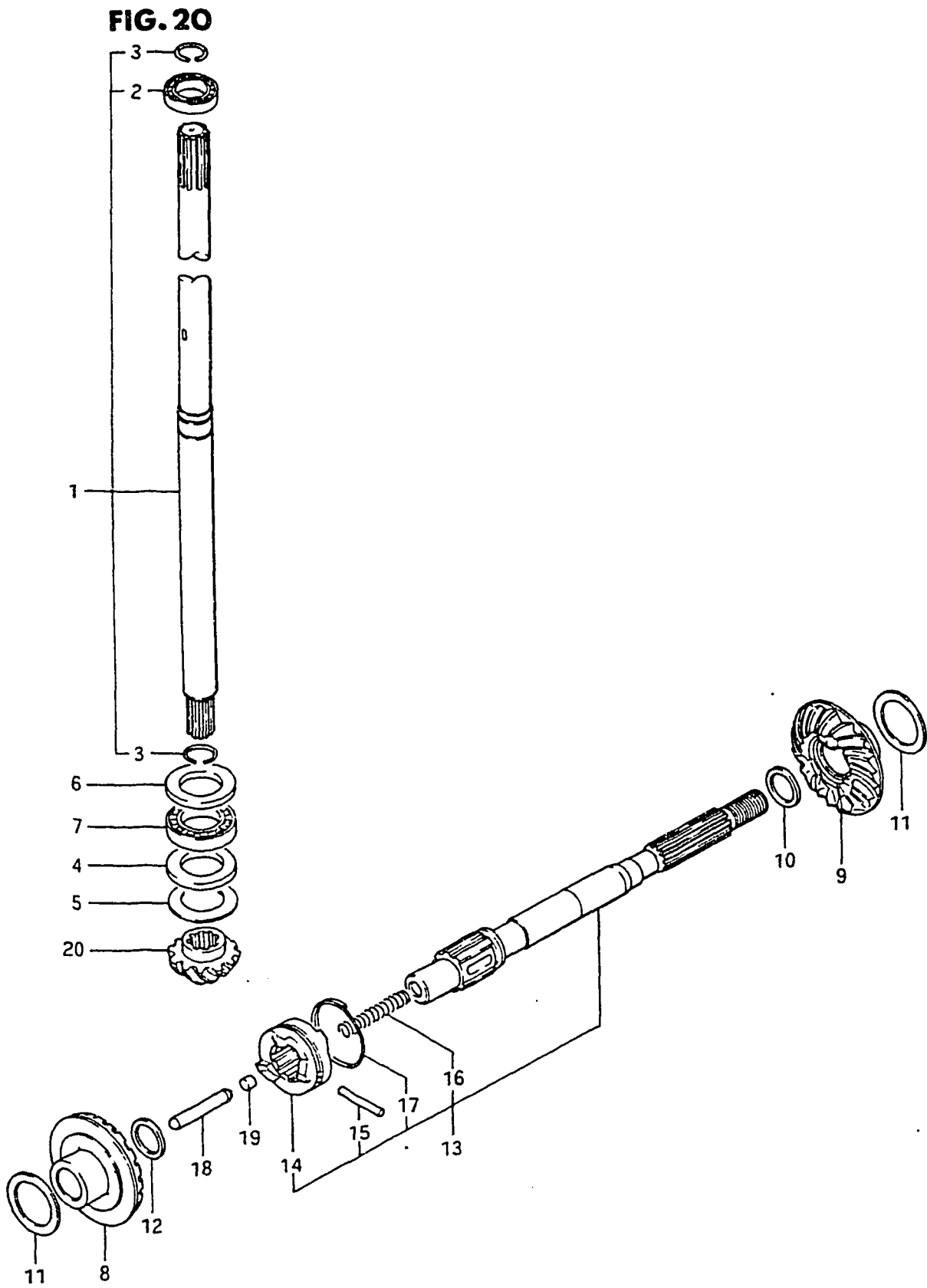

DT9.9 VF E3

REF.NO.	PART NO.	DESCRIPTION	Q'TY	REMARKS
1-1	57100-93910	SHAFT ASSY, drive (S)	1	
1-2	57100-93900	SHAFT ASSY, drive (L)	1	
2	08110-60020	.BEARING	1	
3	09380-15001	.CIRCLIP	2	
4	09160-20027	WASHER (20x35x2.75)	1	
5-1	09160-20041	SHIM (T:1.0)	1	
5-2	09160-20042	SHIM (T:1.1)	1	
5-3	09160-20043	SHIM (T:1.2)	1	
5-4	09160-20044	SHIM (T:1.3)	1	
5-5	09181-20005	SHIM (T:0.7)	1	
5-6	09181-20006	SHIM (T:0.8)	1	
5-7	09181-20007	SHIM (T:0.9)	1	
6	09160-21009	WASHER (21x35x2.75)	1	
7	09263-20024	BEARING (20x35x4.5)	1	
8-1	57510-93901	GEAR, forward	1	~305767
8-2	57510-93902	GEAR, forward	1	305768~
9-1	57521-93901	GEAR, reverse	1	~406234
9-2	57521-93902	GEAR, reverse	1	406235~
10-1	09160-17024	WASHER (T:1.1)	1	
10-2	09160-17025	WASHER (T:1.3)	1	
10-3	09160-17026	WASHER (T:1.5)	1	
10-4	09160-17027	WASHER (T:1.7)	1	
10-5	09160-17028	WASHER (T:1.9)	1	

DT9.9 VF E3

D6



FIG.20 (D- 7) TRANSMISSION

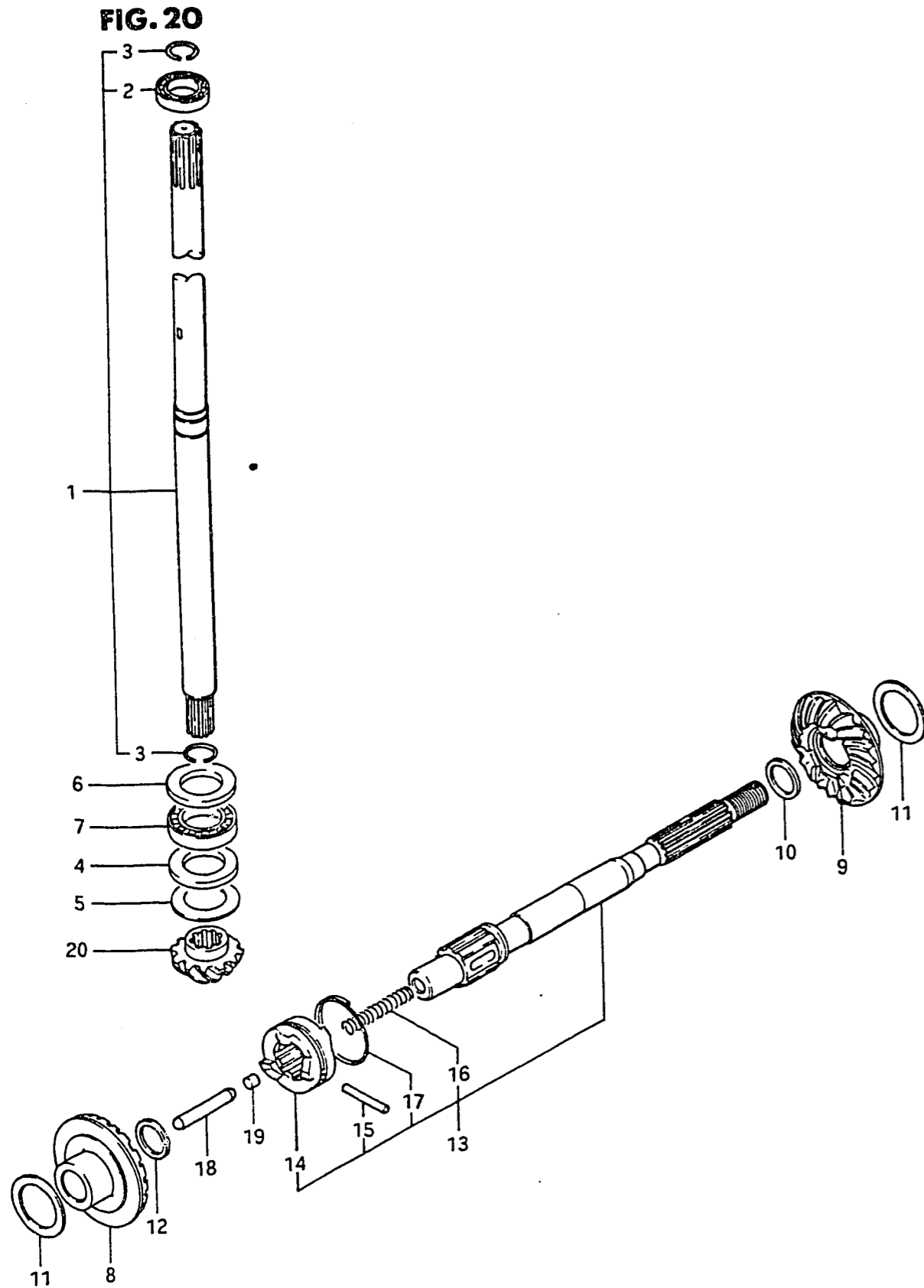

REF.NO.	PART NO.	DESCRIPTION	Q'TY	REMARKS
11-1	09160-25040	SHIM (T:1.0)	2	
11-2	09160-25041	SHIM (T:1.1)	2	
11-3	09160-25042	SHIM (T:1.2)	2	
11-4	09160-25043	SHIM (T:1.3)	2	
11-5	09181-25023	SHIM (T:0.7)	2	
11-6	09181-25024	SHIM (T:0.8)	2	
11-7	09181-25025	SHIM (T:0.9)	2	
12	08211-15222	THRUST WASHER (T:1.5)	1	
13	57600-93901	SHAFT ASSY, propeller	1	
14	57621-93901	.SHIFTER, clutch dog	1	
15	09202-04015	.PIN	1	
16	09440-05027	.SPRING	1	
17	09440-33001	.SPRING	1	
18	57631-93901	ROD, push	1	
19	57632-98500	PIN	1	
20	57311-93901	PINION	1	

FIG. 21

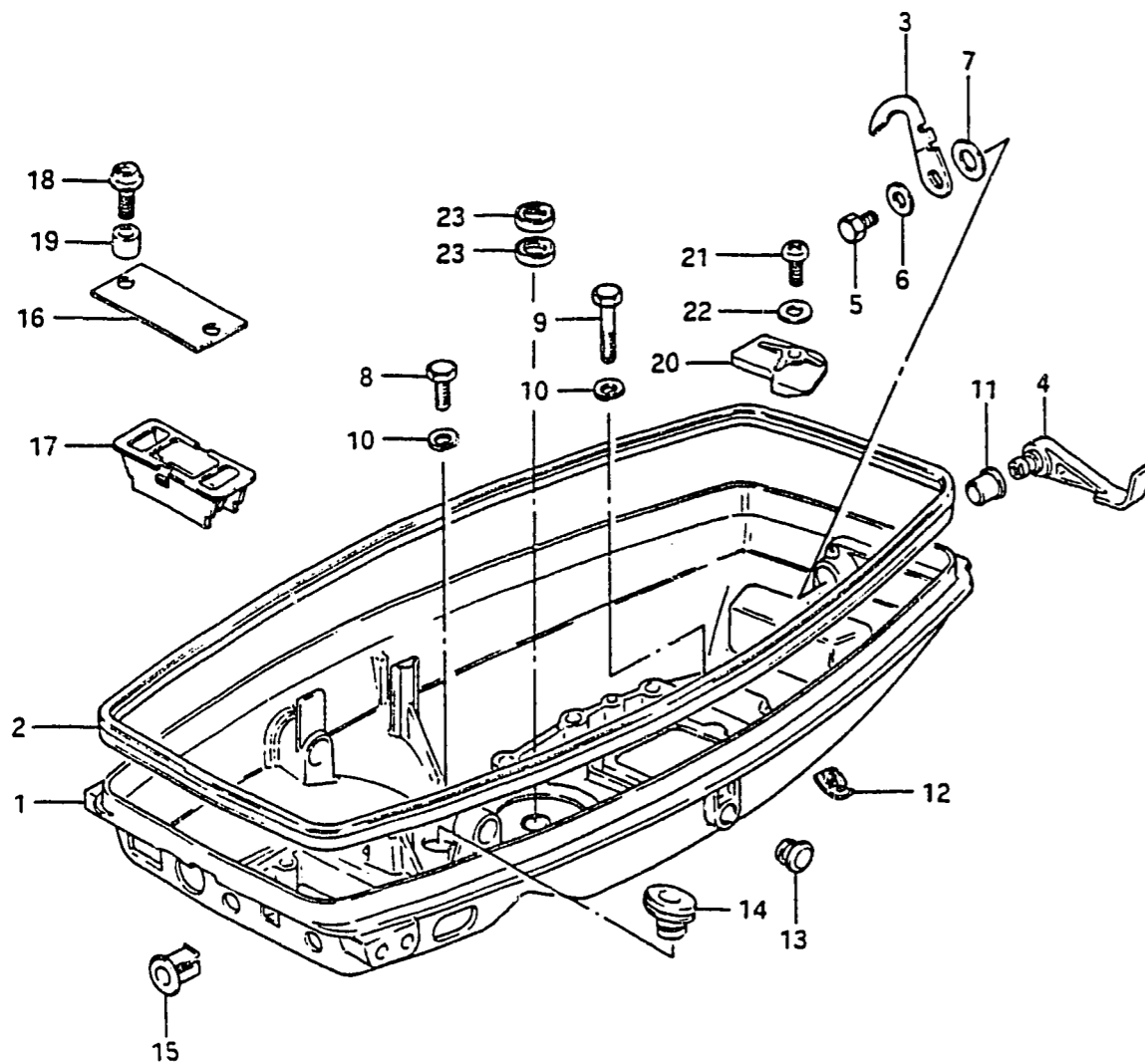

FIG. 21 (D- 8) LOWER COVER

REF.NO.	PART NO.	DESCRIPTION	Q'TY	REMARKS
1-1	61111-93902-02M	COVER, engine under	1	~305580
1-2	61111-93903-02M	COVER, engine under	1	305581~411464
1-3	61111-93904-02M	COVER, engine under	1	411465~
2-1	61112-93900	RUBBER, under cover	1	~410589
2-2	61112-93901	RUBBER, under cover	1	410590~
3-1	61631-96300	RACK, under cover	1	~406190
3-2	61631-96301	RACK, under cover	1	406191~
4	61633-93900-02M	LEVER, hook	1	
5	01107-06108	BOLT	1	
6	08322-21068	WASHER	1	
7	09164-13005	WASHER	1	
8	01107-06258	BOLT	2	
9	09100-06033	BOLT (6x35)	2	
10	08321-21067	LOCK WASHER	4	
11	09306-13002	BUSH	1	
12	61139-96301	CAP, drain	1	
13	09250-10012	CAP	1	
14	23131-93900	BOOT, clutch rod	1	
15	13632-93900	GROMMET, chock knob	1	
16	61117-93900	COVER, air intake	1	~305767
17-1	61117-93910	COVER, air intake	1	305768~406190
17-2	61117-93911	COVER, air intake	1	406191~
18	09103-06048	BOLT	2	~305767
19	09180-06089	SPACER	2	~305767
20	61138-93900	COVER, water	1	411465~
21	02112-06128	SCREW	2	411465~
22	08321-21068	WASHER	2	411465~
23	09282-12002	OIL SEAL (12.8x25x7)	2	

FIG. 22

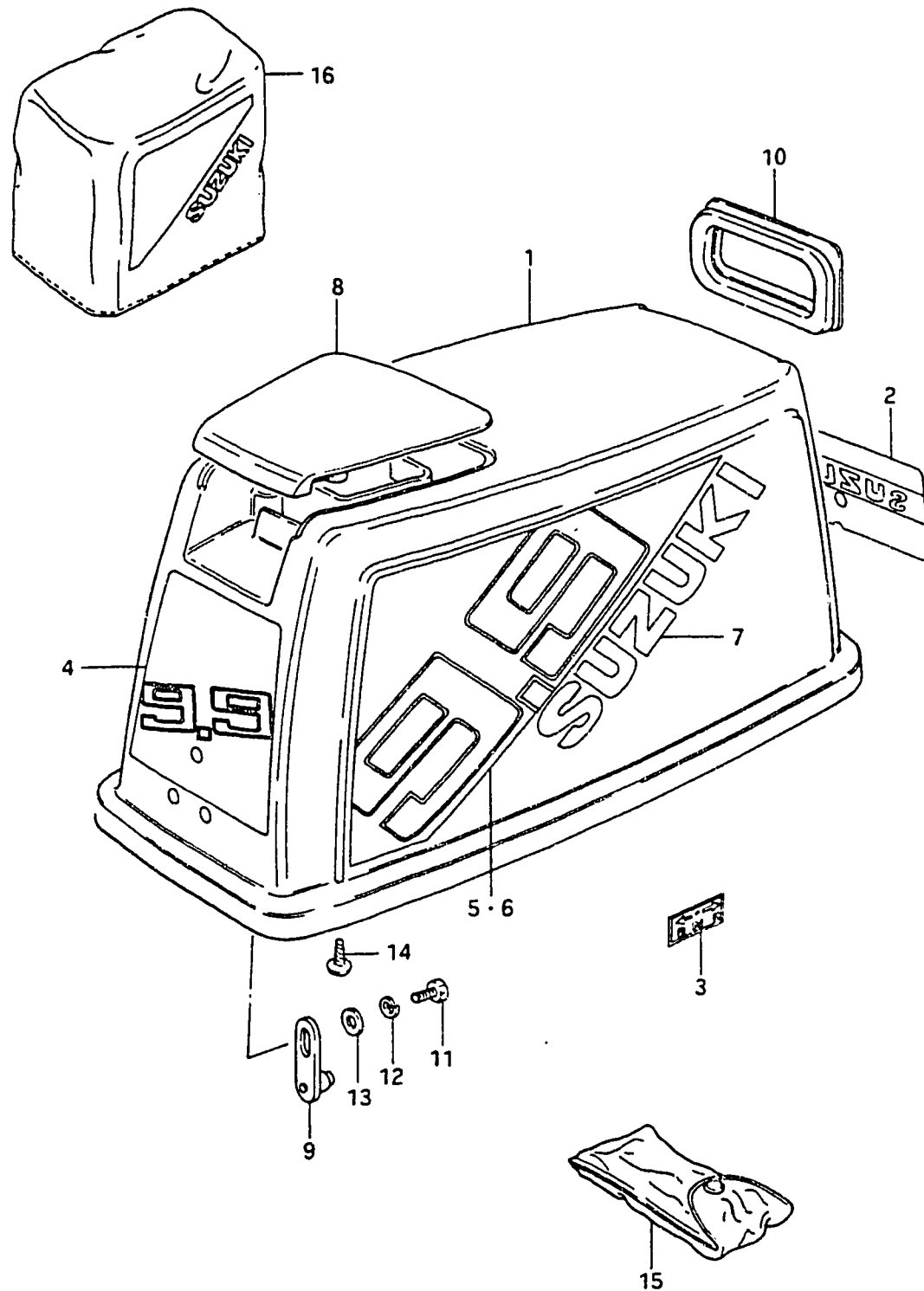

FIG. 22 (D- 9) ENGINE COVER

REF.NO.	PART NO.	DESCRIPTION	Q'TY	REMARKS
1-1	61402-93820-02M	COVER SET, engine	1	~410065
1-2	61402-93821-02M	COVER SET, engine	1	410066~
2	61422-93952	.MARK, emblem front	1	
3	21131-96003	.MARK, clutch shift	1	
4	61435-93951	.MARK, emblem rear	1	
5	61443-93952	.DECAL, cover STBD	1	
6	61453-93952	.DECAL, cover PORT	1	
7	61441-96300	.EMBLEM, SUZUKI	2	
8	61431-93901-02M	.HANDLE, tilt up	1	
9	61610-96301	.FASTENER	1	
10	61622-93901	.SEAL, recoil starter	1	
11	01107-06128	.BOLT	1	
12	08321-21068	.LOCK WASHER	1	
13	08322-21068	.WASHER	1	
14	03242-06169	.SCREW	3	
15	09800-81800	TOOL SET	1	
16	68110-93010	COVER, weather	1	OPT

FIG. 23

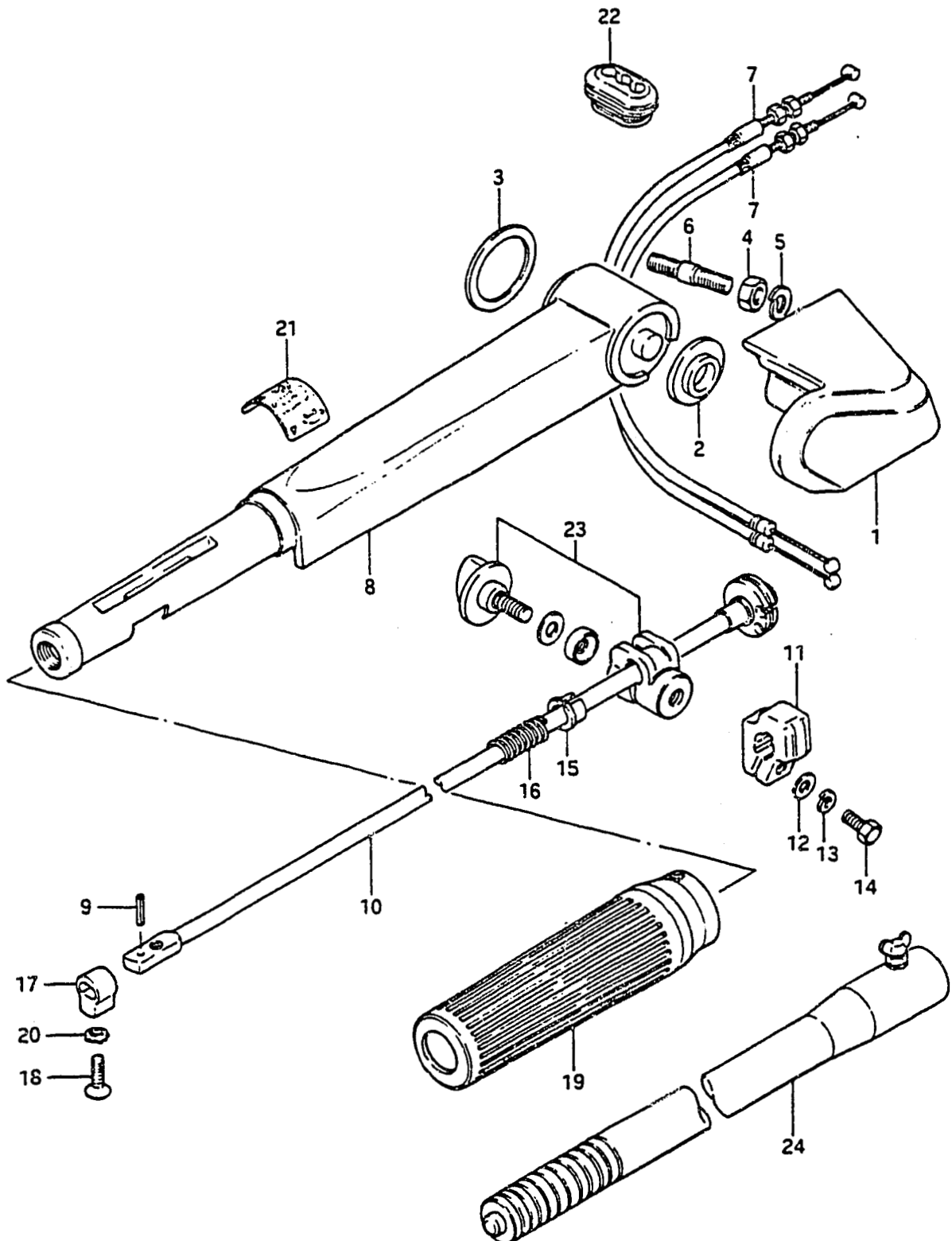

FIG. 23 (D-10) HANDLE

REF.NO.	PART NO.	DESCRIPTION	Q'TY	REMARKS
1	63121-93900-02M	COVER, tiller handle	1	
2	63114-94300	SPACER, handle cover	1	
3	63115-96301	SPACER	1	
4	09140-08016	NUT	2	
5	09162-08007	LOCK WASHER	2	
6	09108-08077	STAND BOLT	2	
7	63610-96320	CABLE ASSY, throttle	2	
8-1	63111-96301-02M	HANDLE, tiller	1	~412879
8-2	63111-96310-02M	HANDLE, tiller	1	512880~
9	63227-93200	PIN, handle rod	1	
10	63220-96300	ROD, handle	1	
11	63241-94300	ADJUSTER, handle grip	1	~412879
12	09160-06015	WASHER (6.5x13x1)	1	~412879
13	09162-06001	LOCK WASHER	1	~412879
14	09100-06020	BOLT (6x20)	1	~412879
15	63225-93200	BUSH, handle rod	1	
16	09440-12027	SPRING	1	
17-1	63223-93200	STOPPER, handle rod	1	~406190
17-2	63223-93201	STOPPER, handle rod	1	406191~
18-1	09126-06004	SCREW	1	~305791
18-2	09126-06006	SCREW	1	305792~
19	63210-93901	GRIP HANDLE	1	
20	09163-06001	LOCK WASHER	1	
21	63215-93400	MARK, handle	1	
22	63625-93900	GROMMET, throttle cable	1	
23	63240-96300	ADJUSTER SET, handle grip	1	512880~
24	63300-93900	BAR ASSY, extension	1	OPT

FIG. 24

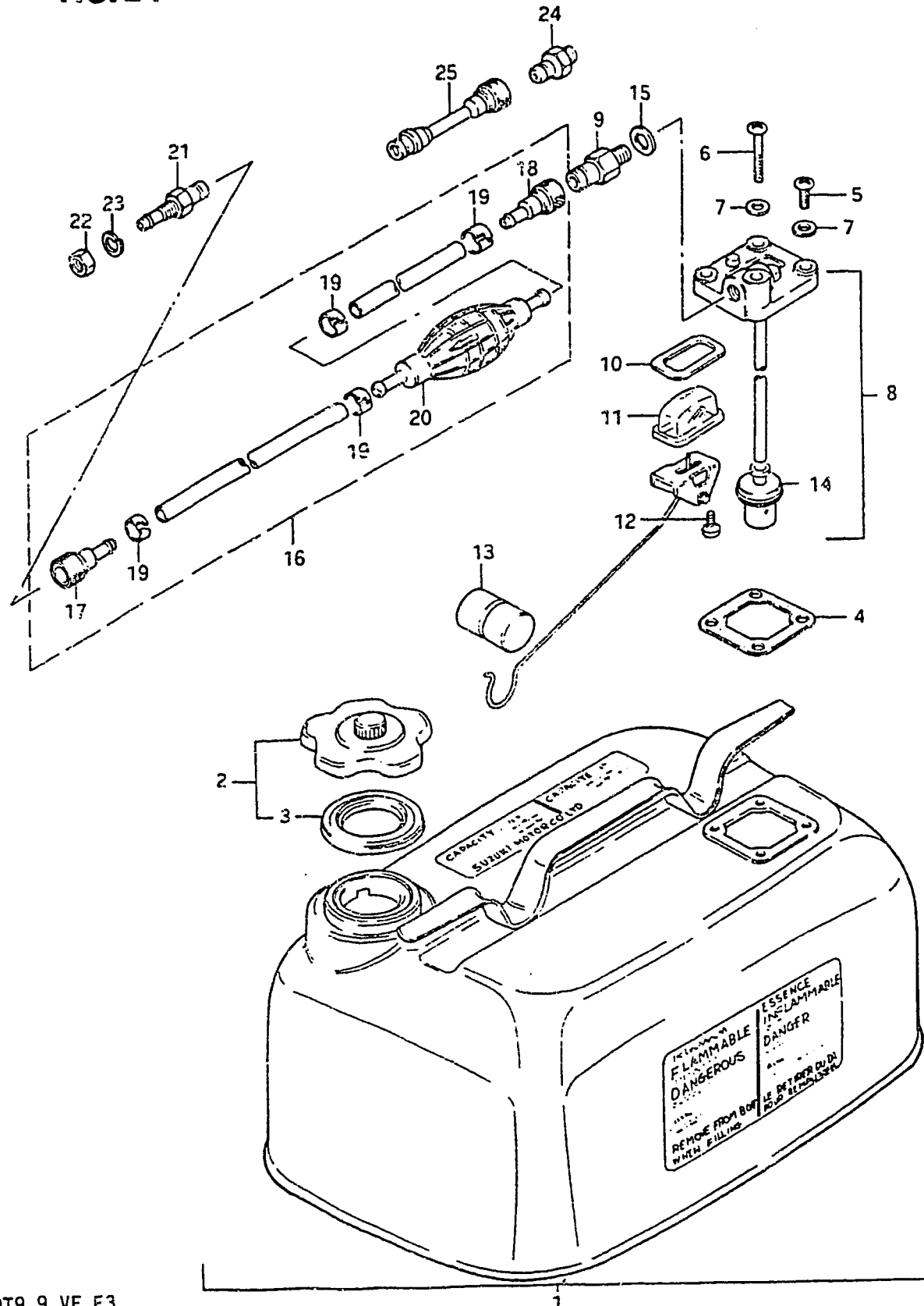

FIG. 24 (D-11) FUEL TANK

REF.NO.	PART NO.	DESCRIPTION	Q'TY	REMARKS
1	65000-95201	TANK SET, fuel 23L	1	
2	65510-98507	.CAP ASSY, separate tank	1	
3	65561-98502	..GASKET, tank cap	1	
4	65871-93010	.GASKET, fuel gauge	1	
5	02112-06168	.SCREW	3	
6	02112-06408	.SCREW	1	
7	09168-06002	..GASKET (6x11.8x1.5)	4	
8	65850-95506	.GAUGE ASSY, fuel	1	
9	65740-95500	..CONNECTOR, male fuel	1	OD:13
10	65854-93001	..GASKET	1	
11	65853-93001	..STRAINER, fuel gauge	1	
12	02112-04108	..SCREW	2	
13	65864-95200	..FLOAT	1	
14	65830-95500	..FILTER	1	
15	09168-12001	..GASKET (12.5x20x1)	1	
16	65700-95205	HOSE ASSY, fuel	1	
17	65750-98505	.CONNECTOR, female fuel	1	ID:11
18	65750-93000	.CONNECTOR, female fuel	1	ID:13
19	65781-98500	.CLIP	4	
20	65770-99702	.PUMP, squeeze	1	
21	65720-98520	CONNECTOR, male fuel	1	QD:11
22	08310-22108	NUT	1	
23	08321-21108	LOCK WASHER	1	
24	65720-98590	CONNECTOR, male fuel	1	OPT; QD:11
25	65700-95271	HOSE, fuel joint	1	OPT; QD:11/ID:13

FIG.25

Q'TY

REMARKS

REF.NO.	PART NO.	DESCRIPTION	Q'TY	REMARKS
1	31101-93900	MOTOR SET, starter	1	
2	33800-93900	SWITCH, starter/cable set	1	
3	32102-93912	FLYWHEEL	1	

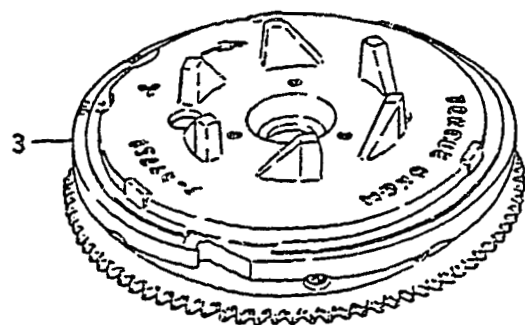
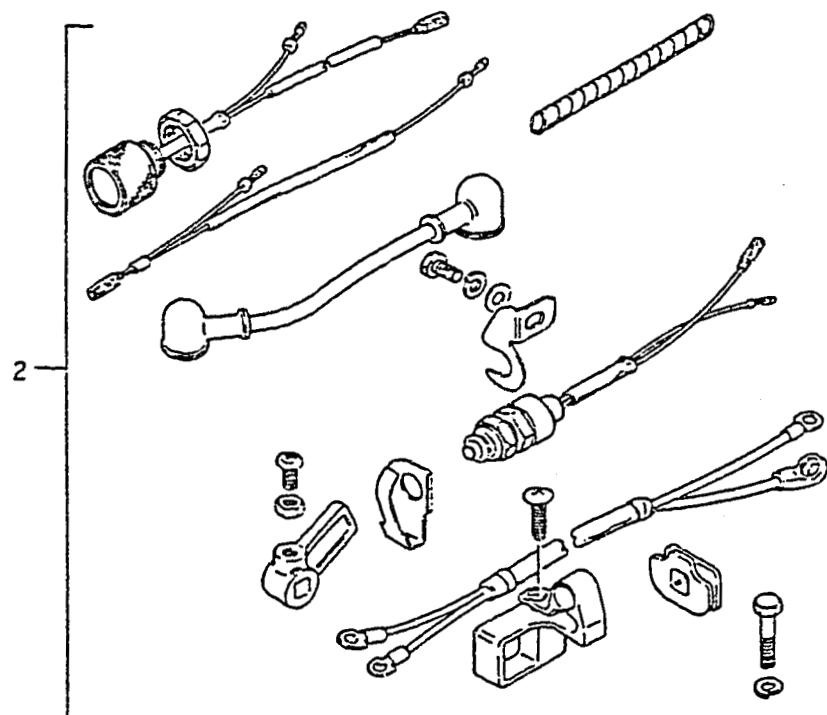
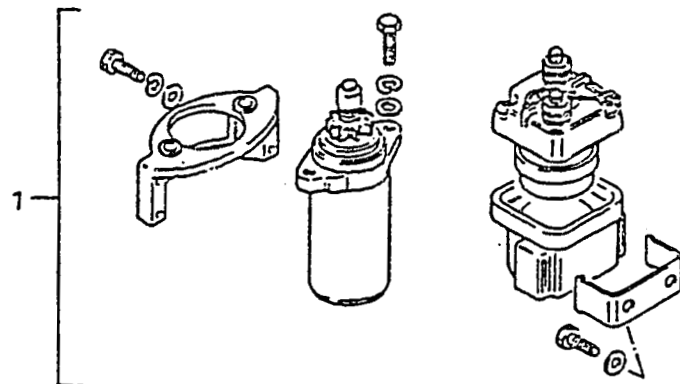

FIG. 26

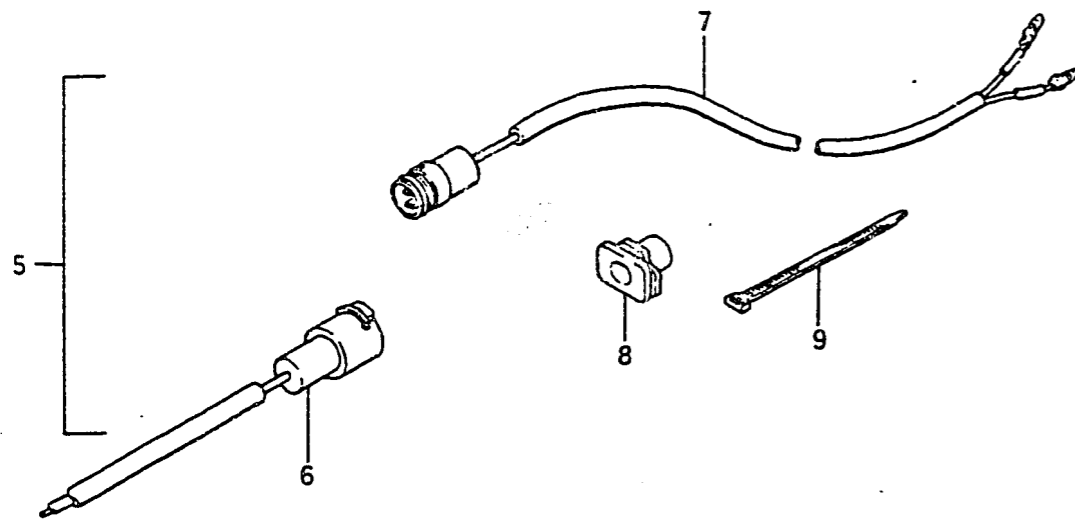
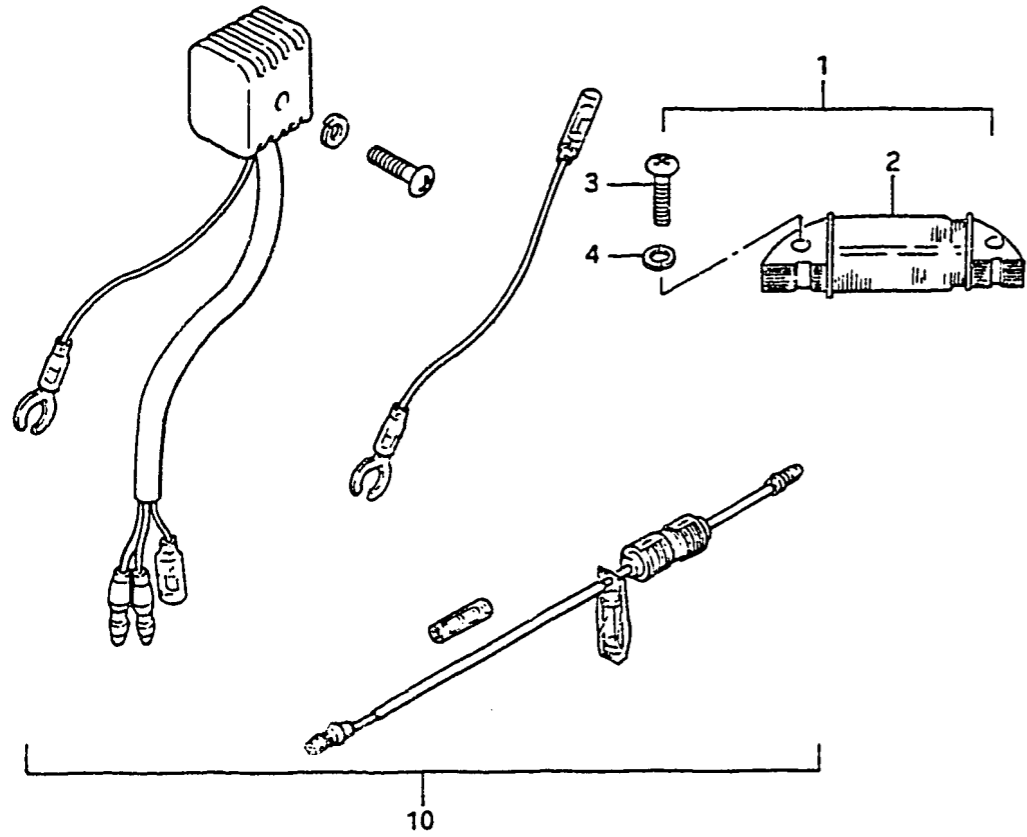
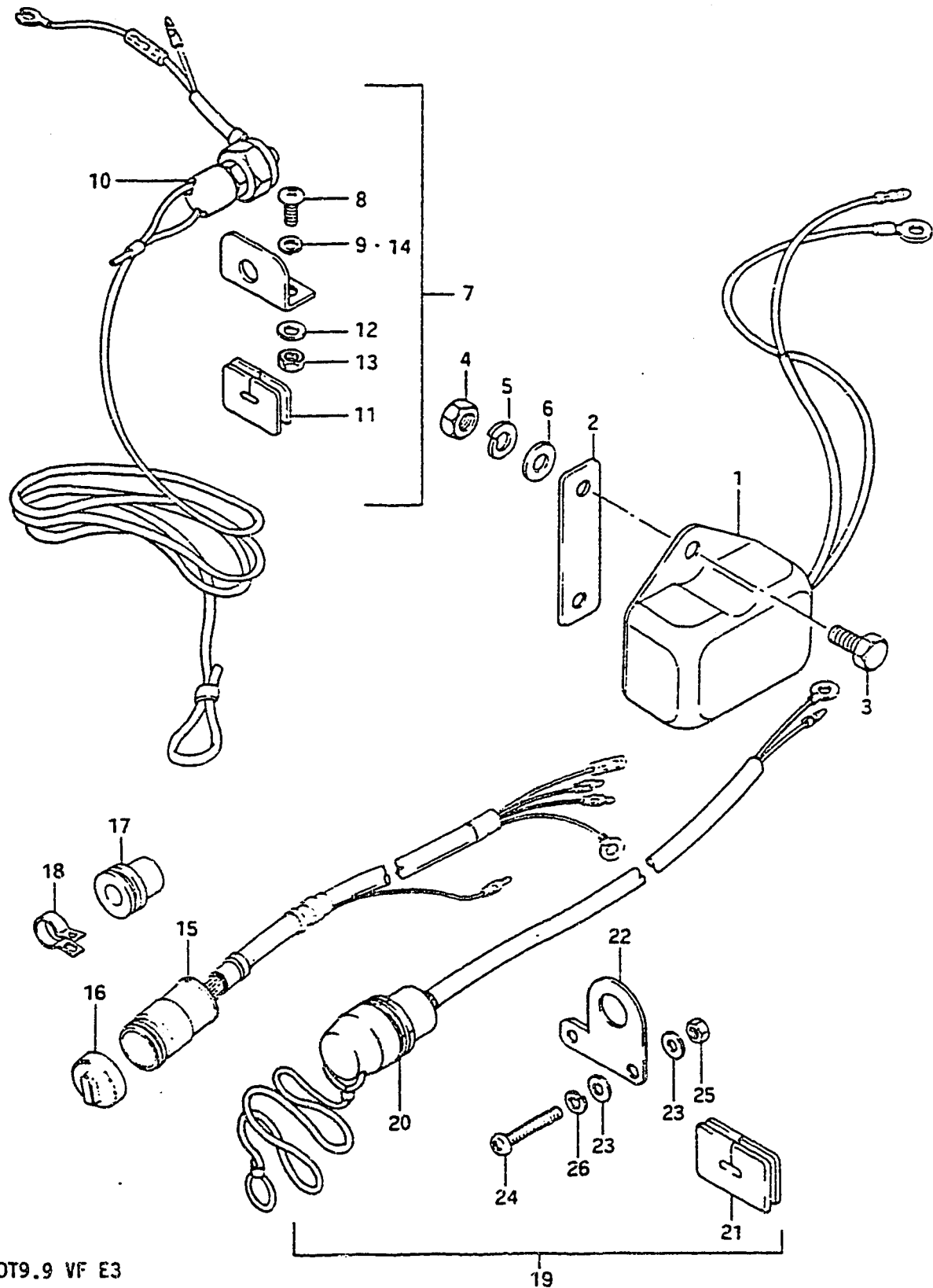

FIG. 26 (E- 3) OPTIONAL : ELECTRICAL (2)

REF.NO.	PART NO.	DESCRIPTION	Q'TY	REMARKS
1	32200-93900	COIL SET, lighting	1	STD
2	32120-93901	.COIL, lighting	1	
3	02112-06258	.SCREW	2	
4	08321-21067	.LOCK WASHER	2	
5	39600-93900	RECEPTACLE SET	1	
6	39602-93900	.PLUG ASSY, lighting	1	
7	39601-93902	.RECEPTACLE ASSY, lighting	1	
8	39603-93900	.GROMMET	1	
9	36632-95501	.CLAMP	1	
10	32801-93901	RECTIFIER SET	1	

FIG. 27

FIG. 27 (E- 4) OPTIONAL : ELECTRICAL (3)



Q'TY

REMARKS

REF.NO.	PART NO.	DESCRIPTION	Q'TY	REMARKS
1	32500-95721	REGULATOR ASSY, voltage	1	
2	32590-93900	STAY, voltage	1	
3	01107-06128	BOLT	2	
4	08310-11068	NUT	2	
5	08321-21067	LOCK WASHER	2	
6	08322-21067	WASHER	2	
7	37802-98300	SWITCH SET, emergency	1	model QD/VE
8	02112-04308	.SCREW	2	
9	08321-21048	.LOCK WASHER	2	
10	37623-95251	.CAP, emergency switch	1	
11	37824-93900	.GROMMET, emergency switch	1	
12	08322-21048	.WASHER	4	
13	08310-11047	.NUT	2	
14	08321-21068	LOCK WASHER	2	
15	36630-93901	WIRING HARNESS ASSY, RE	1	
16	36631-94300	.CAP	1	
17	36612-93900	GROMMET	1	
18	36632-95501	CLAMP	1	
19	37802-93910	SWITCH SET, emergency	1	model VF
20	37820-98110	.SWITCH ASSY, emergency	1	
21	37824-93900	.GROMMET	1	
22	37950-93901	.BRACKET, emergency	1	
23	09160-04016	.WASHER	2	
24	02112-04308	.SCREW	2	
25	08310-11048	.NUT	2	
26	08321-21047	.LOCK WASHER	2	



FIG.28

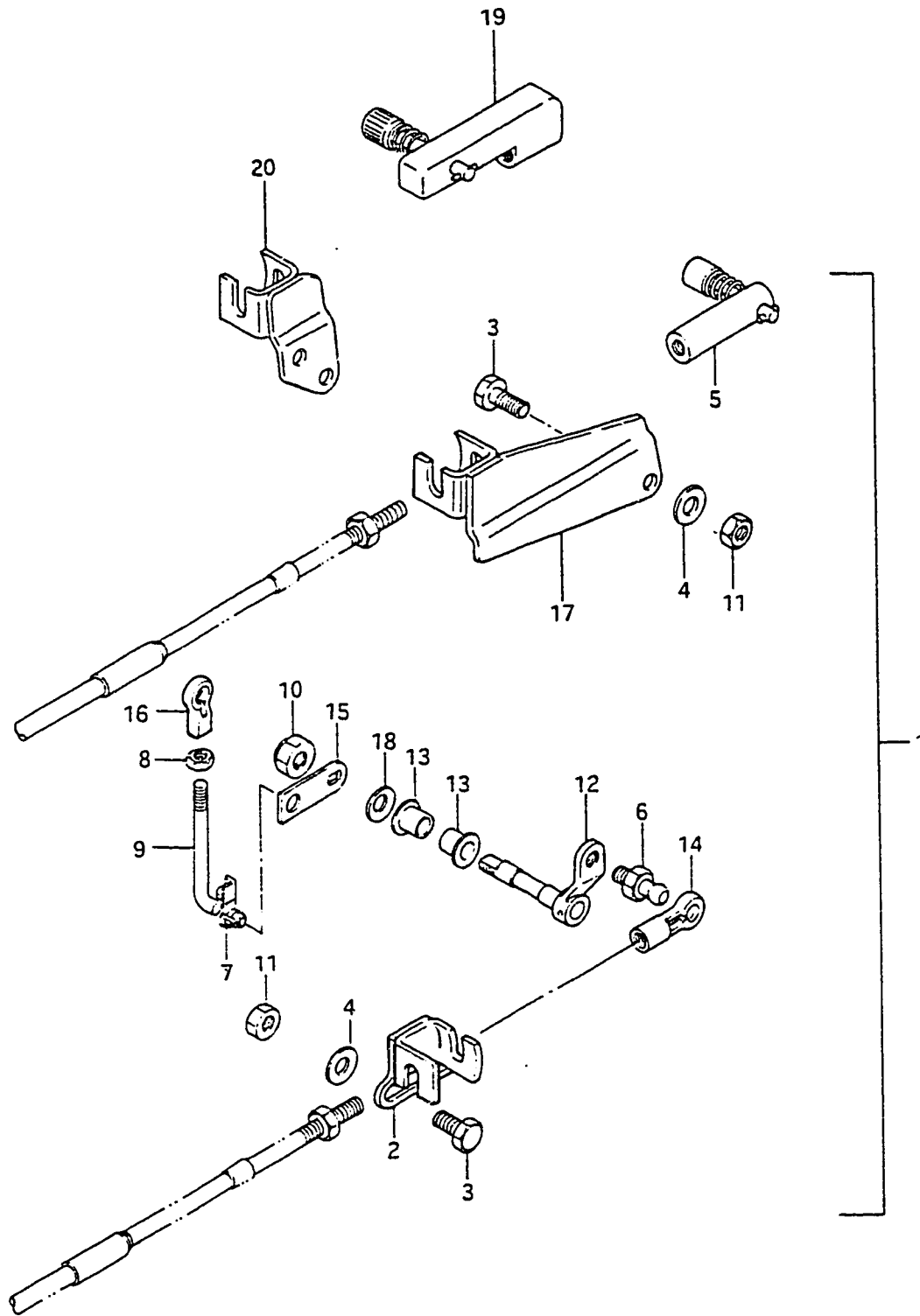

REF.NO.	PART NO.	DESCRIPTION	Q'TY	REMARKS
1-1	67130-93900-02M	REMOTE CONTROL PARTS ASSY	1	~412879
1-2	67130-93901-02M	REMOTE CONTROL PARTS ASSY	1	512880~
2	67340-93900	.HOLDER, remo-con cable	1	
3	09100-06113	.BOLT (6x16)	4	
4	09160-06036	.WASHER (6.5x18x1.5)	4	
5	67440-93701	.GUIDE, clutch calbe	1	for 67130-93900-02M
6	09119-06047	.PAWL PIVOT	1	
7	09209-05017	.PIN	1	
8	09140-05001	.NUT	1	
9	67413-93900	.ROD, remo-con throttle	1	
10	09159-08026	.NUT	1	
11	09140-06004	.NUT	4	
12	67410-93500-02M	.LEVER, remo-con throttle	1	
13	09306-08003	.BUSH	2	
14	67466-95200	.CONNECTOR, remo-con throttle	1	
15	67417-93900	.ARM, remo-con throttle	1	
16	19131-95501	.CONNECTOR, throttle lever	1	
17	67270-93900	.HOLDER REMO-CON CABLE	1	for 67130-93900-02M
18	09164-08017	.WASHER	1	
19	67440-93900	.GUIDE, clutch cable	1	for 67130-93901-02M
20	67270-93910	.HOLDER REMO-CON CABLE	1	for 67130-93901-02M

FIG.29 (E- 6) OPTIONAL : REMOTE CONTROL (1)

FIG.29

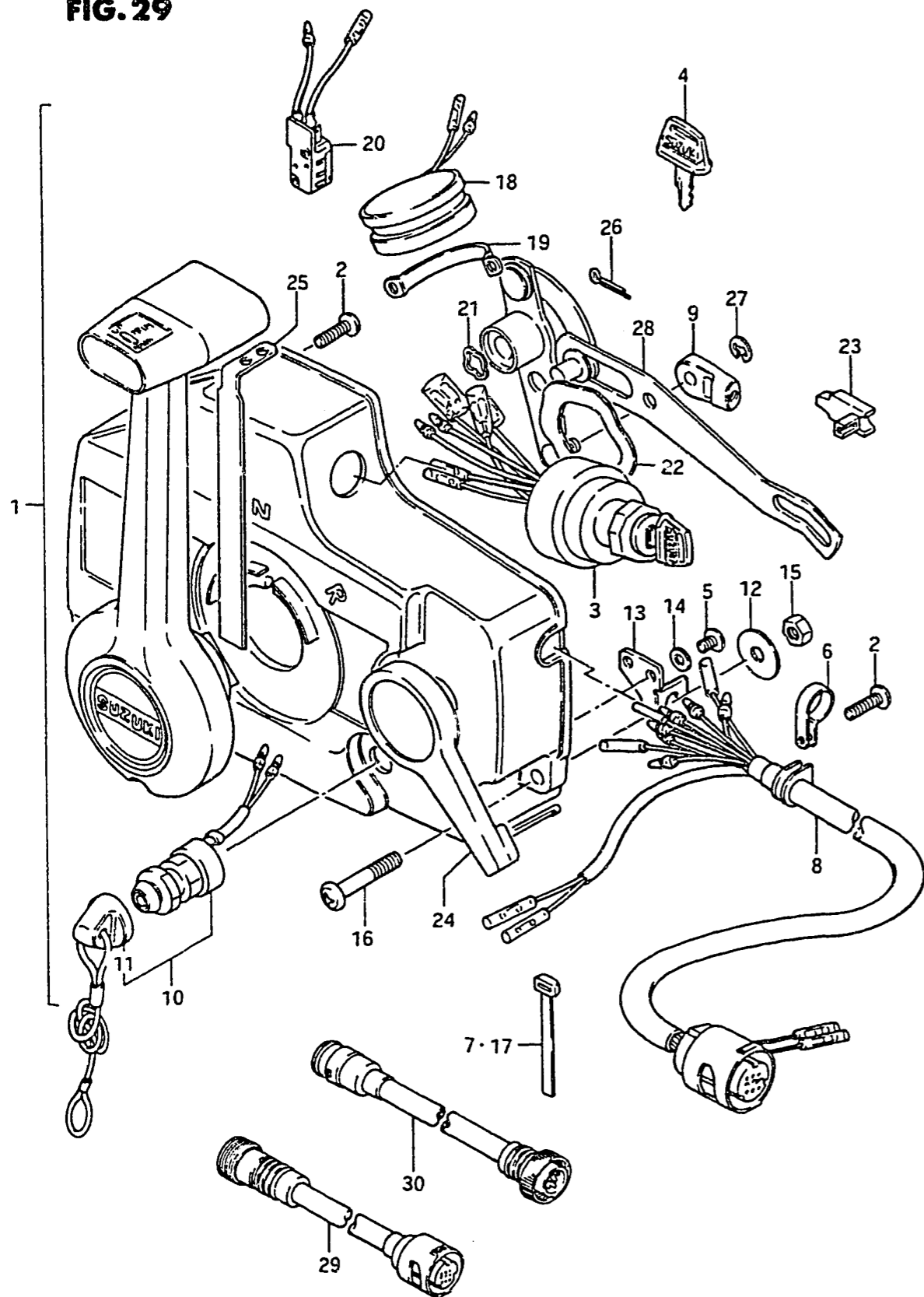

Q'TY

REMARKS

REF.NO.	PART NO.	DESCRIPTION	Q'TY	REMARKS
1	67200-95551	BOX ASSY, remo-con	1	
2	67296-94300	.SCREW	3	
3	37110-94301	.SWITCH, ignition	1	
4-1	37141-93300	..KEY, 8511	1	(1) Key Comes Standard
4-2	37141-93310	..KEY, 8512	1	
4-3	37141-93320	..KEY, 8513	1	
4-4	37141-93330	..KEY, 8611	1	
4-5	37141-93340	..KEY, 8612	1	
4-6	37141-93350	..KEY, 8613	1	
5	67296-94310	.SCREW	6	
6	36622-94300	.CLAMP	1	
7	36632-95501	.BAND	1	
8	36620-94320	.WIRING HARNESS	1	
9	67275-94300	.CABLE END	2	
10	37820-96302	.SWITCH ASSY, emergency	1	
11	37823-95251	..CAP/ROPE	1	
12	67288-94300	.WASHER	6	
13	67271-94300	.HOLDER, cable	1	
14	67288-94310	.WASHER	3	
15	09140-06004	.NUT	3	
16	09125-06012	.SCREW	3	
17	37119-94300	.BAND	2	
18	38500-95503	.BUZZER	1	
19	38501-95500	.BAND	1	
20	37721-95551	.SWITCH, neutral	1	
21	67232-94300	.BUSH	1	
22	67252-94300	.BUSH	1	
23	67214-94300	.ACTUATOR	1	
24	67241-94300	.LEVER, free throttle	1	
25	67255-94300	.ARM, neutral lock	1	
26	67293-94300	.PIN	1	
27	67292-94300	.E RING	3	
28	67220-94300	.PLATE ASSY	1	
29	36641-94701	ADAPTOR (O.N)	1	
30	36642-94702	ADAPTOR (N.O)	1	

NOTE: Choke solenoid not available

FIG. 30

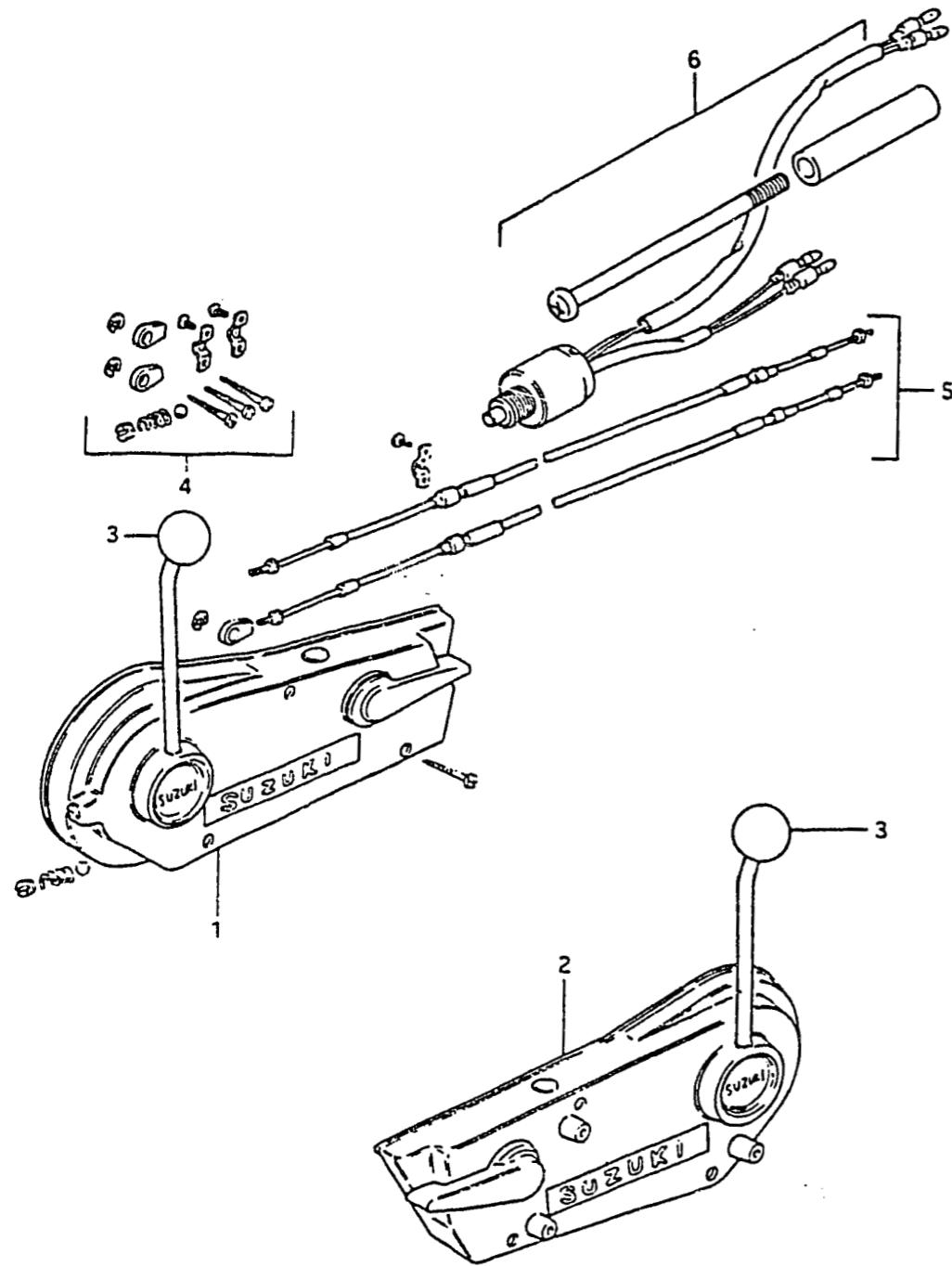

FIG.30 (E-7) OPTIONAL : REMOTE CONTROL (2)

REF.NO.	PART NO.	DESCRIPTION	Q'TY	REMARKS
1	67200-95203	BOX ASSY, remo-con STBD	1	ML Remote Control Box
2	67200-95213	BOX ASSY, remo-con PORT	1	ML Remote Control Box
3	67214-95200	.KNOB, control Box	1	
4	67300-95810	.HOLDER SET, remo-con cable	1	
5-1	99105-00006	CABLE, remote control	2	L: 6 ft.
5-2	99105-00007	CABLE, remote control	2	L: 7 ft.
5-3	99105-00008	CABLE, remote control	2	L: 8 ft.
5-4	99105-00009	CABLE, remote control	2	L: 9 ft.
5-5	99105-00010	CABLE, remote control	2	L: 10 ft.
5-6	99105-00011	CABLE, remote control	2	L: 11 ft.
5-7	99105-00012	CABLE, remote control	2	L: 12 ft.
5-8	99105-00013	CABLE, remote control	2	L: 13 ft.
5-9	99105-00014	CABLE, remote control	2	L: 14 ft.
5-10	99105-00015	CABLE, remote control	2	L: 15 ft.
5-11	99105-00016	CABLE, remote control	2	L: 16 ft.
5-12	99105-00017	CABLE, remote control	2	L: 17 ft.
5-13	99105-00018	CABLE, remote control	2	L: 18 ft.
5-14	99105-00019	CABLE, remote control	2	L: 19 ft.
5-15	99105-00020	CABLE, remote control	2	L: 20 ft.
5-16	99105-00022	CABLE, remote control	2	L: 22 ft.
6	67140-95300	.ATTACHMENT, twin remo-con kit	1	For NA05 Control Box
7	67140-95600	.ATTACHMENT, twin remo-con kit	1	For NA12S Control Box

FIG.31

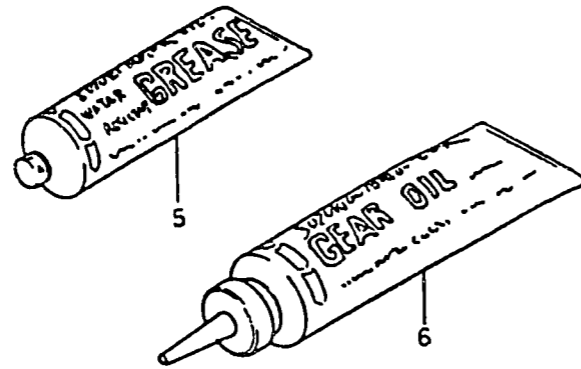
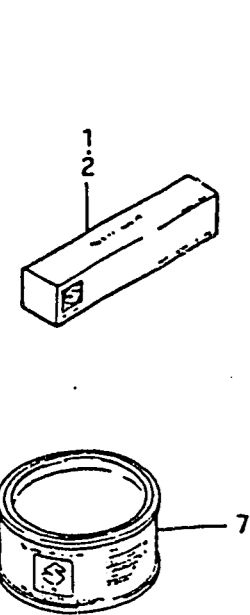

FIG.31 (E- 8) OPTIONAL

REF.NO.	PART NO.	DESCRIPTION	Q'TY	REMARKS
1	99000-31030	GASKET, liquid No.4	1	100g
2	99000-31050	SUZUKI BOND, No.1	1	100g
3	99000-31120	SUZUKI SILICON SEAL	1	50g
4	99000-32050	THREAD LOCK CEMENT, super	1	50g
5-1	99000-25160	GREASE, water resistant	1	250g
5-2	99000-25170	GREASE, water resistant	1	50g
6	99000-22540	GEAR OIL, outboard motor	1	400cc
7	99000-25010	SUZUKI SUPER GREASE	1	450g
8	99000-32020	THREAD LOCK CEMENT, super	1	50g,103Q
10-1	99000-10109-01T	PAINT (FRANCOIS WHITE)	1	90g
10-2	99000-10209-02M	PAINT (ARCTIC SUKVER)	1	90g