



SUZUKI MARINE

Parts Book

DT 8 (1980-1982)



1703 Hwy 35 So., Laurence Harbor, NJ 08879

(732) 264-7176

(800) 338-0645 FAX (732) 264-2472

www.brownspoint.com

PREFACE

When it becomes necessary to replace parts on SUZUKI OUTBOARD MOTORS, always use SUZUKI GENUINE PARTS which have passed a strict inspection which guarantees quality and performance.

This parts catalogue covers the list of all service parts for SUZUKI DT5, DT8.

A. INSTRUCTIONS FOR QUOTING THE CATALOGUE

1. DIMENSIONS

Dimensions of the parts in this catalogue are indicated in unit millimeters.

2. ABBREVIATIONS

Abbreviations used in this catalogue are as follows:

AR	:	As required	NT	:	Number of teeth
ASSY	:	Assembly	OPT	:	Optional
E.No.	:	Engine Number	OS	:	Over Size
F.No.	:	Frame Number	STD	:	Standard
d	:	Diameter of material	T	:	Thickness
ID	:	Inside diameter	US	:	Under size
OD	:	Outside diameter	W	:	Width
L	:	Length	LHD	:	Left handle drive
LH	:	Left hand side	RHD	:	Right handle drive
RH	:	Right hand side	S.L,UL,LL	:	Transom type

~123456 : Up to E.No.0501-123456

123456~ : From E.No.0501-123456

12 x 34 x 5.6Figures in the description column show the dimensions of parts.

ID OD T(or W,L)

The number of letter shown below Q'ty indicate the MODEL NAME as shown below.

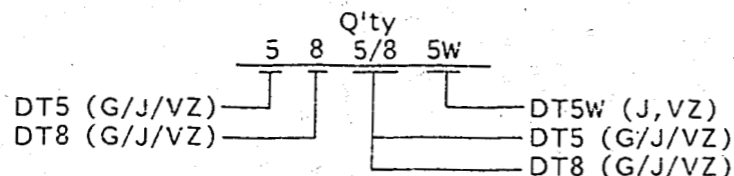

3. INNER PARTS OF ASSEMBLY

Parts number that have a period (.) mark in front of the part description on a text page are separately serviced parts of the assembly.

4. MODIFICATION NOTICE

A parts bulletin will be sent to you on all occasions when changes in parts occur, including interchangeable modifications between new parts and old ones.

5. NOTE

5-1. There are some different parts from those of production models among spare parts for the administrative reasons and common use of them with other models.

5-2. In respect of rubber hoses and vinyl tubes, please be sure to use them by cutting off according to the length mentioned on parts catalogue or what is actually required on the vehicle.

5-3. Note that the drawings on the illustration page are for ready reference of spare parts number, not to be used as an assembly manual.
When assembling, use "SUZUKI SERVICE MANUAL".

6. SPECIFICATION CODE

This catalogue contains the parts for the model designed for the following spec.;

spec. code:	DT5G	: E1, E3, E9, E13, E28:
	DT5J	: E1, E3, E9, E13, E28.
	DT5VZ	: E1, E13, E28, E40.
	DT8G	: E1, E3, E9, E13, E28.
	DT8J	: E1, E3, E9, E13, E28.
	DT8VZ	: E1, E13, E28, E40.
	DT5WJ	: E1
	DT5WVZ	: E1

7. SERIAL ENGINE NUMBER

	DT5G	
DT5G	: 0501-001001~	
DT5J	: 0501-1xxxxx~	DT5WJ : 0501-150001~
	DT5J	
DT5VZ	: 0501-2xxxxx~	DT5WVZ : 0502-2xxxxx~
	DT5VZ	
	DT8G	
DT8G	: 0801-001001~	
DT8J	: 0801-1xxxxx~	
	DT8J	
DT8VZ	: 0801-2xxxxx~	
	DT8VZ	

FIG.3

B - 7

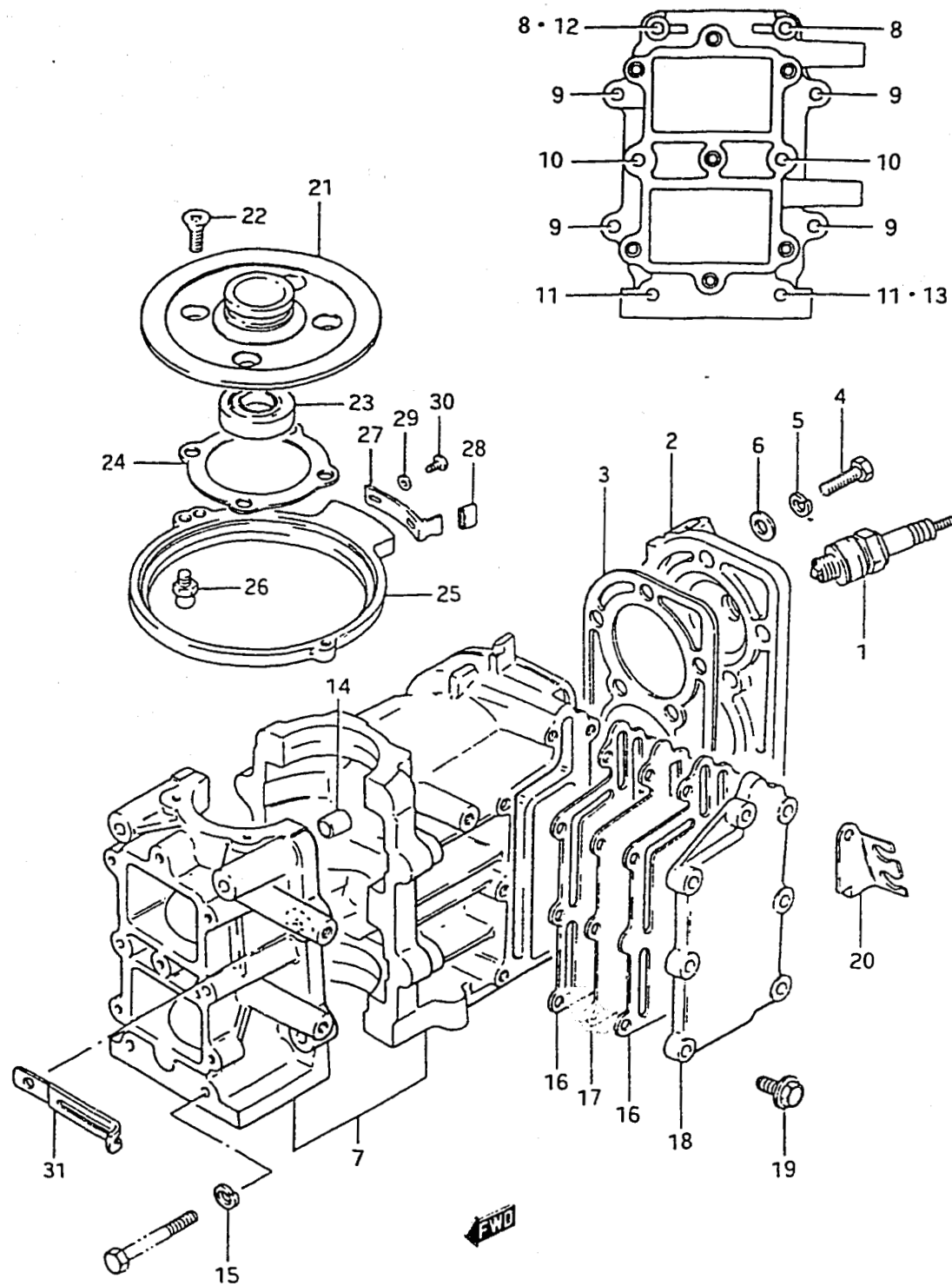

5

FIG.3 CYLINDER DT8 (G/J)

Ref. No.	Part No.	Description	Q'ty	Remarks
1-1	09482-00141	SPARK PLUG ASSY (BPR6HS)	2	gap:7,model G
1-2	09482-00229	SPARK PLUG ASSY (BPR6HS)	2	gap:9,model G
1-3	09482-00229	SPARK PLUG ASSY (BPR6HS)	2	gap:9,model J E28
1-4	09482-00084	SPARK PLUG ASSY (BP6HS)	2	gap:8,model G(E9,E13)
1-5	09482-00133	SPARK PLUG ASSY (BP6HS)	2	gap:9,E9,E13 to 09482-00259
1-6	09482-00133	SPARK PLUG ASSY (BP6HS)	2	gap:9,model J to 09482-00259
2	11110-98100-01J	CYLINDER HEAD	1	
3	11141-98100	GASKET, cylinder head	1	
4	01107-08358	BOLT, cylinder head	8	
5	08321-21088	LOCK WASHER	8	
6	08322-11088	WASHER	8	
7-1	11300-98100-01J	CYLINDER / CRANKCASE ASSY	1	model G to 11300-98101-01J
7-2	11300-98101-01J	CYLINDER / CRANKCASE ASSY	1	model G
7-3	11301-98101-01J	CYLINDER / CRANKCASE ASSY	1	model J from 11300-98101-01J
8-1	01107-06508	•BOLT 2 (for 11300-98100-01J)	2	model G
8-2	01107-06508	•BOLT 2	1	for 11300-98101-01J for 11301-98101-01J
9	01107-06308	•BOLT 1	4	model G
10	01107-06758	•BOLT 4	2	
11-1	01107-06608	•BOLT 3	2	model G
11-2	01107-06608	•BOLT 3	1	
12	01107-06558	•BOLT 5	1	
13	01107-06658	•BOLT 6	1	
14	04211-09109	•DOWEL PIN	2	
15	08321-21068	•LOCK WASHER	10	
16	14151-98100	GASKET, exhaust coaver (T:1)	2	
17	14131-98100	PLATE, exhaust cover (T:1)	1	
18	14141-98100-01J	COVER, exhaust	1	
19	01527-06258	BOLT	7	

FIG.1 (B-2, 3, 4) : DT5 (G/J)
 FIG.2 (B-5) : DT5VZ
 FIG.4 (B-9) : DT8VZ

FIG.3

B - 8

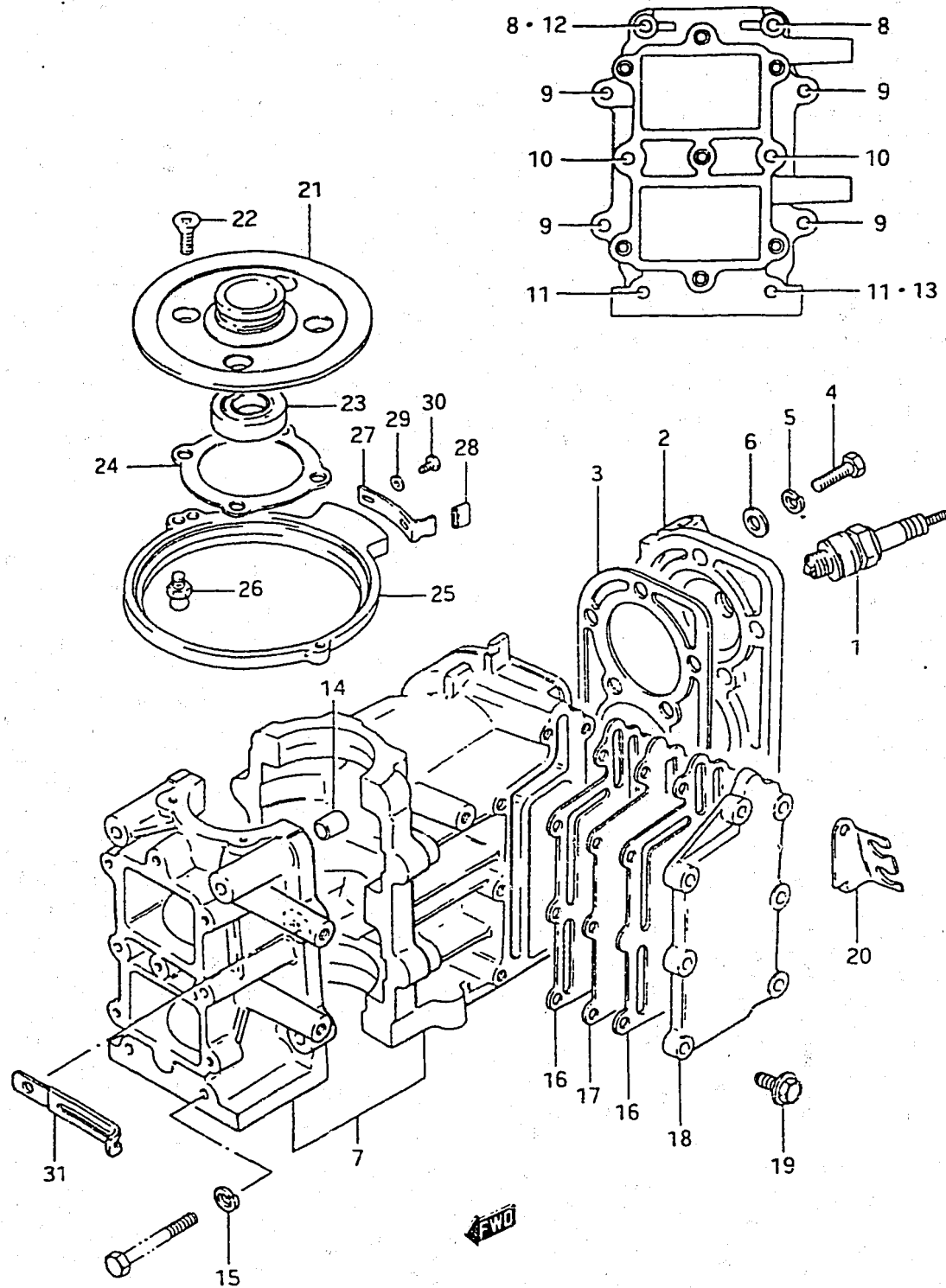

6

FIG.3 CYLINDER

Ref. No.	Part No.	Description	Q'ty	Remarks
20	33883-98101-01J	STAY, high tension cord	1	
21	11411-98500	HOUSING, upper oil seal	1	
22	02122-06168	SCREW	4	
23	09283-20006	OIL SEAL, upper crank shaft	1	
24	11413-98500	GASKET, upper oil seal housing	1	
25	19151-98100-01J	RETAINER, stator	1	
26	09119-06047	BALL, pivot	1	from 09119-06039
27	19172-98100	STOPPER, retainer	1	
28	09320-05010	CUSHION, retainer stopper	1	
29-1	08322-21058	WASHER	2	model G, to 09160-05028
29-2	09160-05028	WASHER	2	model J
30	02112-05128	SCREW	2	
31	09404-06403	CLAMP, magneto lead wire	1	model G to 09404-06413

FIG.1 (B-2, 3, 4) : DT5 (G/J)
 FIG.2 (B-5) : DT5VZ
 FIG.4 (B-9) : DT8VZ

FIG.4

B - 9

FIG.4 CYLINDER DT8 VZ

Ref. No.	Part No.	Description	Q'ty	Remarks
1-1	09482-00229	SPARK PLAG ASSY (BPR6HS)	2	gap:9, E28
1-2	09482-00259	SPARK PLAG ASSY (BP6HS)	2	gap:9, E13, E40
1-3	09482-00074	SPARK PLAG ASSY (BP6HS)	2	gap:9
2	11110-98100-01J	CYLINDER HEAD	1	
3	11141-98100	GASKET, cylinder head	1	
4	01907-08358	BOLT, cylinder head	8	to 01107-08358
5	08321-21088	LOCK WASHER	8	
6	08322-11088	WASHER	8	
7	11301-98190-01J	CYLINDER / CRANKCASE ASSY	1	from 11301-98101-01J
8	01907-06508	•BOLT 2	1	
9	01907-06308	•BOLT 1	4	to 01107-06308
10	01907-06758	•BOLT 4	1	to 01107-06758
11	01907-06608	•BOLT 3	1	
12	01907-06558	•BOLT 5	1	to 01107-06558
13	01907-06658	•BOLT 6	1	to 01107-06658
14	09100-06060	•BOLT 7	1	E13, E40
15	08321-21068	•WASHER	1	
16	04211-09109	•DOWEL PIN	2	
17	08321-21068	•LOCK WASHER	10	
18	14151-98100	GASKET, exhaust cover (T:1)	2	
19	14131-98100	PLATE, exhaust cover (T:1)	1	
20	14141-98100-01J	COVER, exhaust	1	
21	01107-06258	BOLT	7	
22	08322-21068	WASHER	7	
23	33883-98101-01J	STAY, high tension cord	1	
24	11411-98500	HOUSING, upper oil seal	1	
25	02122-06168	SCREW	4	
26	09283-20006	OIL SEAL, upper crankshaft	1	
27	11413-98500	GASKET, upper, oil seal housing	1	
28	19151-98100-01J	RETAINER, stator	1	
29	09119-06047	BALL, pivot	1	from 09119-06039
30	19172-98100	STOPPER, retainer	1	
31	09320-05010	CUSHION, retainer stopper	1	
32	09160-05028	WASHER	2	
33	02112-05128	SCREW	2	

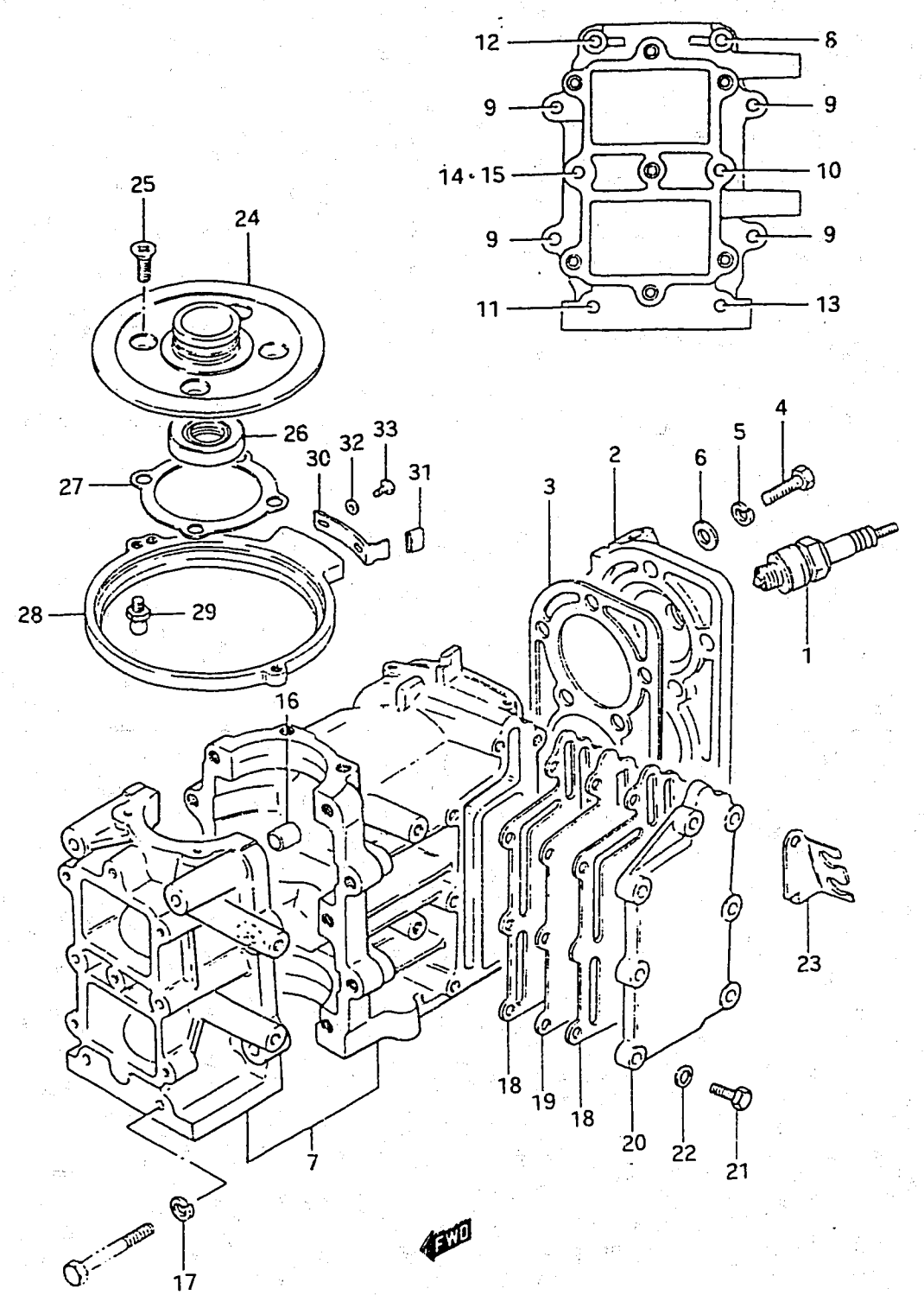
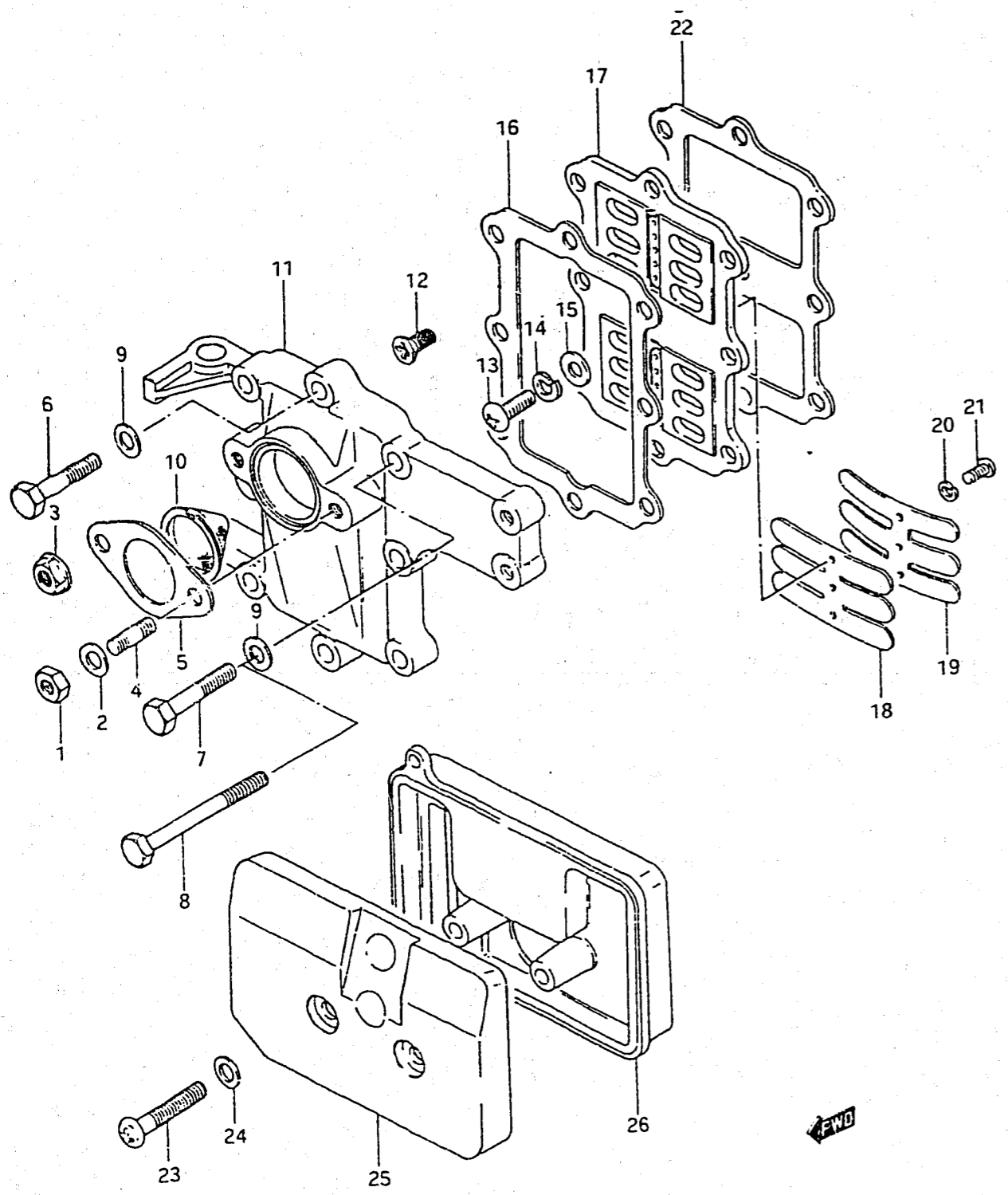

FIG.1 (B-2, 3, 4) : DT5 (G/J)
 FIG.2 (B-5) : DT5 VZ
 FIG.3 (B-7, 8) : DT8 (G/J)

FIG.6

B - 12

FIG.6 DT8 REED VALVE



Ref. No.	Part No.	Description	Q'ty	Remarks
1	08310-11068	NUT	2	model G/J
2	08322-21068	WASHER	2	
3	08316-16068	NUT	2	model VZ
4-1	01421-06168	STUD BOLT	2	model G
4-2	01411-06168	STUD BOLT	2	model J/VZ
5	13125-98100	GASKET, carburetor	1	
6-1	01107-06308	BOLT 1	5	model G/J
6-2	01907-06308	BOLT 1 (to 01107-06308)	5	model VZ
7-1	01107-06358	BOLT 2	1	
7-2	01907-06358	BOLT 2 (to 01107-06358)	1	
8	01107-06603	BOLT 3	1	model VZ(E13,E40)
9-1	08322-21068	WASHER	6	
9-2	08322-21068	WASHER	7	
10	13130-98100	NET, inlet case	1	
11	13111-98101-01J	CASE, inlet	1	
12	02122-06108	SCREW	1	model G
13	02112-06168	SCREW, valve seat	1	
14	08321-21068	LOCK WASHER	1	model J/VZ
15	08322-21068	WASHER	1	
16	13121-98100	GASKET, inlet	1	
17	13150-98100	VALVE ASSY, reed	1	
18	13153-98100	·VALVE, reed	2	
19	13152-98100	·STOPPER, reed valve	2	
20	08321-21038	·LOCK WASHER	6	
21	02112-03068	·SCREW	6	
22-1	13122-98100	GASKET, valve seat	1	to 13122-98101, model G
22-2	13122-98101	GASKET, valve seat	1	
23	02112-06358	SCREW	2	
24	08322-11068	WASHER	2	
25	13812-98100	COVER, silencer	1	
26	13811-98100	CASE, silencer	1	

FIG.5 (B-11) : DT5

FIG.7

B - 14

10

FIG.7 THROTTLE CONTROL

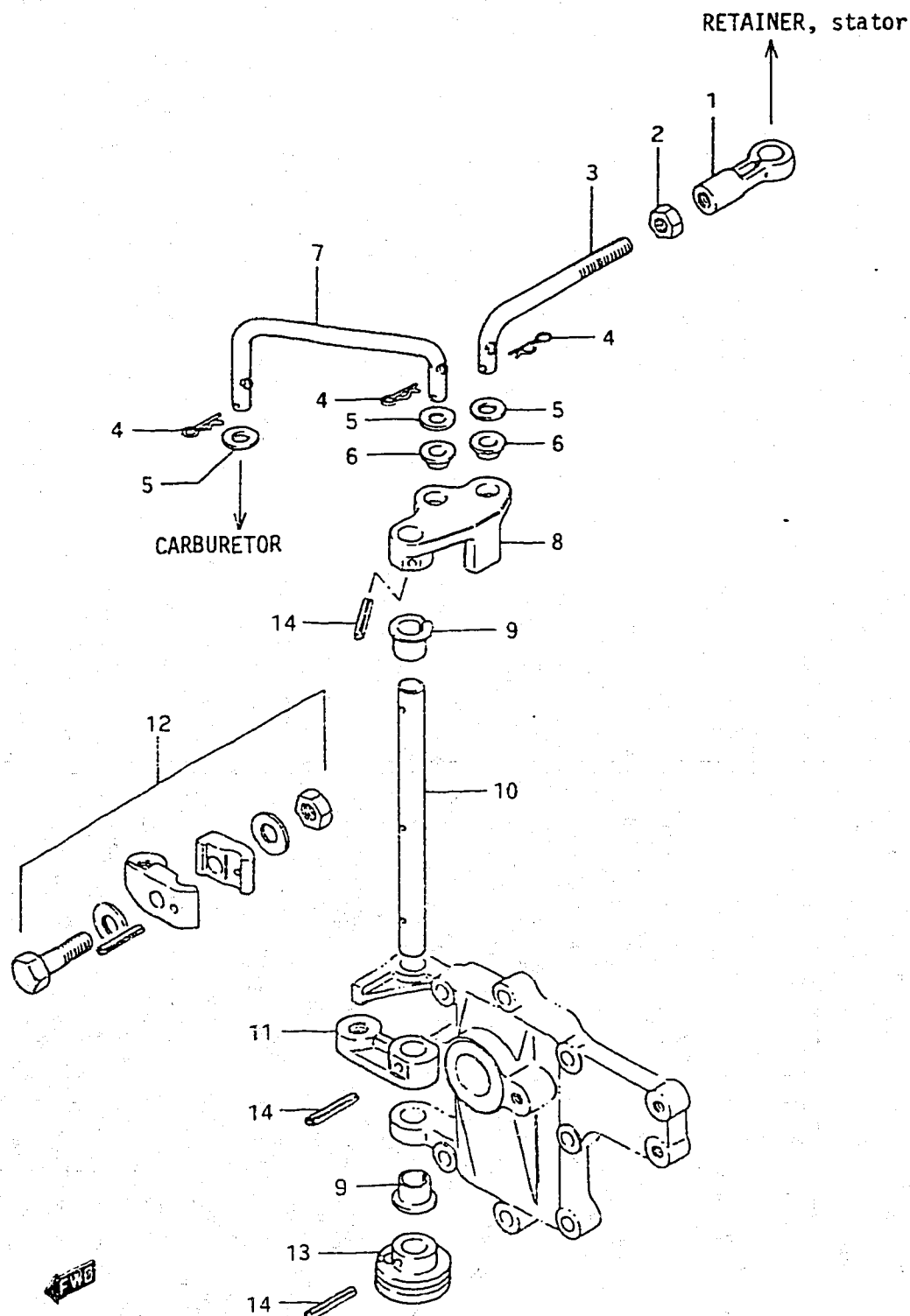

Ref. No.	Part No.	Description	Q'ty	5/8	Remarks
1	67463-95200	CONNECTOR, startor link	1		
2	08310-11058	NUT	1		
3	19171-98100	LINK, stator	1		
4	09385-05004	CLIP, link	3		
5	09160-05010	WASHER, link	3		
6-1	09306-05001	BUSHING, throttle	2		model G
6-2	09306-05002	BUSHING, throttle	2		for 19181-98102-01J
7-1	19111-98500	LINK, throttle	1		DT5
7-2	19111-98101	LINK, throttle	1		DT8 G/J from 19111-98100
7-3	19111-98102	LINK, throttle	1		DT8 VZ
8-1	19181-98100-01J	LEVER, throttle $\phi 7$	1		to 19181-98101-01J model G
8-2	19181-98101-01J	LEVER, throttle $\phi 7.2$	1		to 19181-98102-01J use to 09306-05002
8-3	19181-98102-01J	LEVER, throttle $\phi 8.2$	1		to 19181-98110-01J
8-4	19181-98110-01J	LEVER, throttle	1		DT8J/VZ, DT5 VZ
9	63225-93200	BUSHING, throttle lever shaft	2		
10-1	19174-98500	SHAFT, throttle lever	1		DT5
10-2	19174-98100	SHAFT, throttle lever	1		DT8
11	19191-98100-01J	ARM, remote control	1		model G
12	19190-98110	ARM SET, remote control	1		CPT, model J/VZ
13	63222-93200	DRUM, throttle	1		
14-1	63227-93200	PIN, throttle lever shaft	3		model G
14-2	63227-93200	PIN, throttle lever shaft	2		model J/VZ

FIG.9

C - 4

12

FIG.9 DT8 CRANKSHAFT

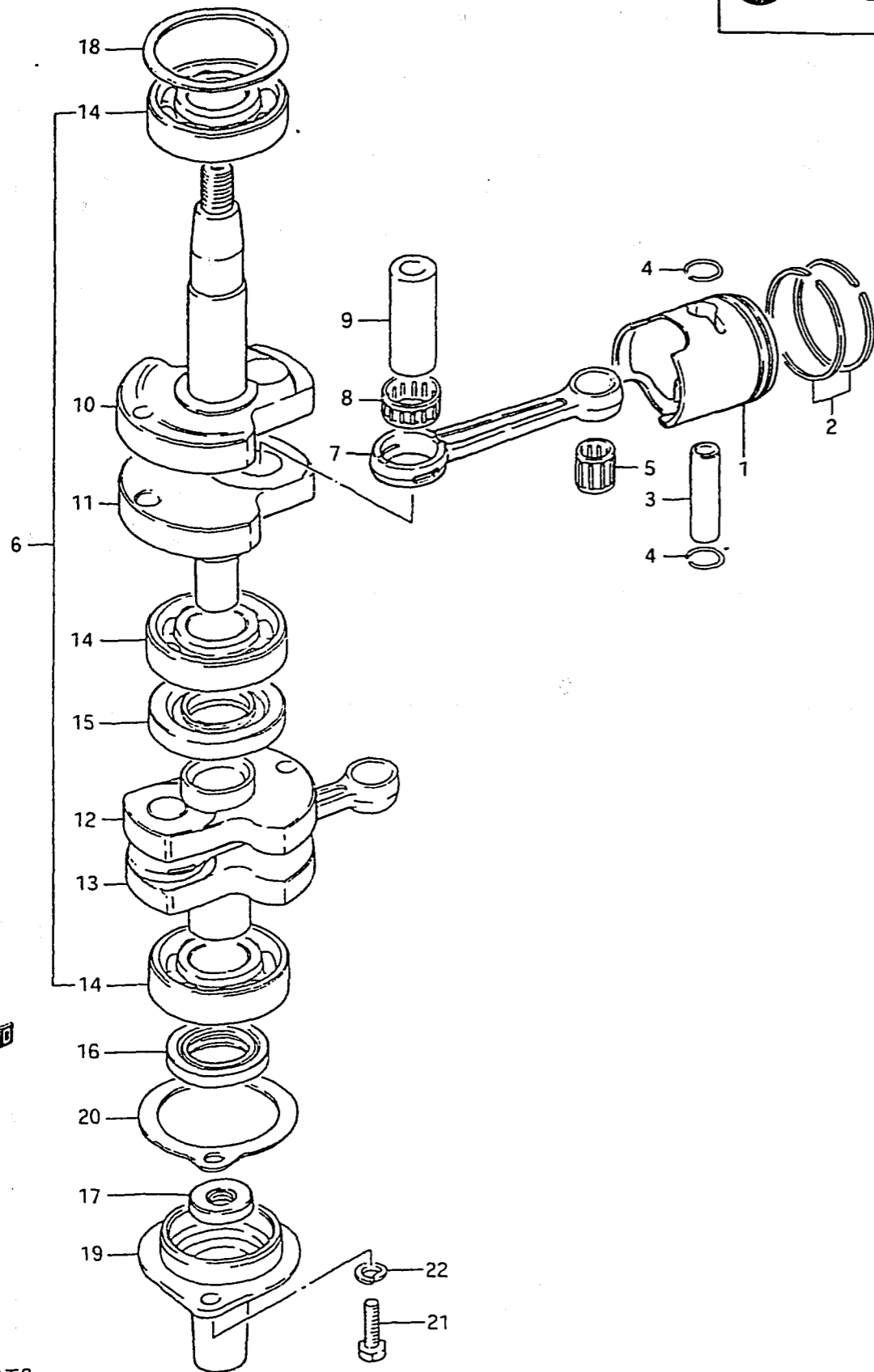

Ref. No.	Part No.	Description	Q'ty	Remarks
1-1	12110-96102	PISTON (STD)	2	
1-2	12110-96102-025	PISTON (OS:0.25)	2	OPT
1-3	12110-96102-050	PISTON (OS:0.5)	2	OPT
2-1	12140-99603	RING SET, piston (STD)	2	
2-2	12140-28630-025	RING SET, piston (OS:0.25)	2	OPT
2-3	12140-28630-050	RING SET, piston (OS:0.5)	2	OPT
3	12151-25000	PIN, piston	2	
4	09381-12001	CIRCLIP, piston pin	4	
5-1	09263-12003	BEARING, piston pin	2	model G/J to 09263-12015
5-2	09263-12015	BEARING, piston pin	2	model VZ
6-1	12200-98860	CRANKSHAFT ASSY	1	model G
6-2	12200-98101	CRANKSHAFT ASSY	1	model J/VZ from 12200-98860
7	12161-96000	•ROD, connecting	2	
8	09263-17005	•BEARING, crank pin	2	
9	12211-96001	•PIN, crank	2	
10	12221-98100	•CRANKSHAFT, upper	1	
11	12231-98100	•WHEEL, upper crankshaft	1	
12	12232-98100	•WHEEL, lower crankshaft	1	
13	12240-98100	•CRANKSHAFT, lower	1	
14	08113-62040	•BEARING	3	
15	09289-22004	•OIL SEAL, middle crankshaft	1	
16-1	09283-20022	OIL SEAL, lower crankshaft	1	to 09283-20035,model G
16-2	09283-20035	OIL SEAL, lower crankshaft	1	
17-1	09283-10002	OIL SEAL, driveshaft upper	1	to 09283-10003,model G
17-2	09283-10003	OIL SEAL, driveshaft upper	1	
18	09160-35001	SHIM, upper crankshaft	0~1	model G
19	11431-98501	HOUSING, lower oil seal	1	
20	11433-98500	GASKET, lower oil seal	1	
21	09100-06020	BOLT	2	
22	09162-06001	LOCK WASHER	2	

FIG.8 (C-2) : DT5

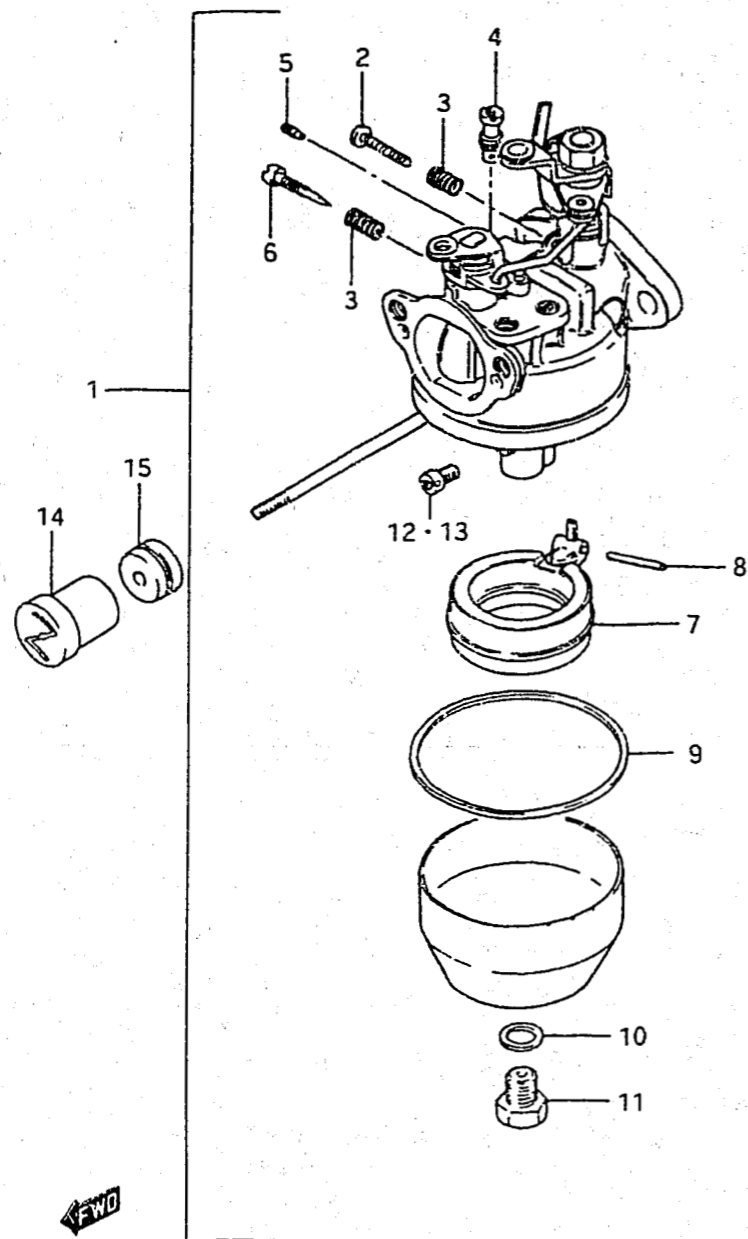

Ref. No.	Part No.	Description	Q'ty	Remarks
1-1	13200-98100	CARBURETOR ASSY (model G)	1	Stamp:98100,L type
1-2	13200-98101	CARBURETOR ASSY (model J)	1	Stamp:98101,L type from 13200-98100 to 13200-98102
1-3	13200-98102	CARBURATOR ASSY (model VZ)	1	Stamp:93102,L type
1-4	13200-98110	CARBURETOR ASSY (model G)	1	Stamp:98110,S type
1-5	13200-98111	CARBURETOR ASSY (model J)	1	Stamp:98111,S type from 13200-98110 to 13200-98112
1-6	13200-98112	CARBURATOR ASSY (model VZ)	1	Stamp:98112,S type
2	13267-98100	•SCREW, throttle stop	1	
3	13268-96110	•SPRING	2	
4	09492-50008	•PILOT JET (#50)	1	
5	09493-24007	•JET, air	1	
6	13269-98100	•SCREW, pilot air	1	
7-1	13250-98100	•FLOAT	1	model G/J to 13250-98110
7-2	13250-98110	•FLOAT	1	model VZ
8	13254-98100	•PIN, float	1	
9	13251-98100	•GASKET, float chamber	1	
10	13343-98100	•GASKET	1	
11	13613-98100	•BOLT	1	
12-1	09491-20010	•JET, main (#100) (L type)	1	for 13200-98101
12-2	09491-95007	•JET, main (#95) (S type)	1	for 13200-98110, 13200-98111, 13200-98112
13-1	09491-90004	JET, main (#90)	1	} OPT
13-2	09491-85007	JET, main (#85)	1	
13-3	09491-21012	JET, main (#105)	1	
14	13631-93500	KNOB, starter	1	
15	09305-04005	BUSHING, starter knob	1	

FIG. 10 (C-6) : DT5

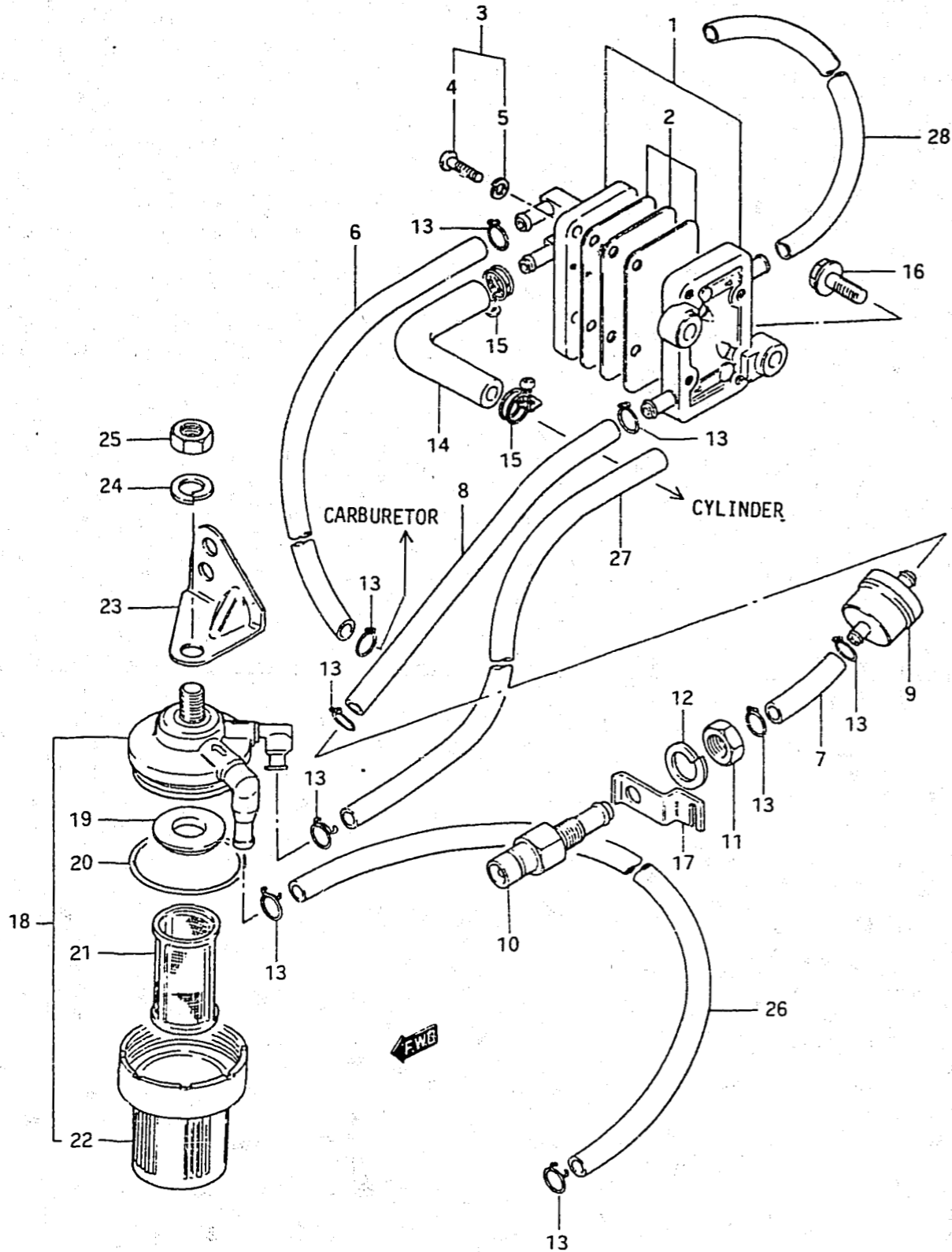

Ref. No.	Part No.	Description	Q'ty		Remarks
			5	8	
1	15100-98100	PUMP ASSY, fuel	1	1	
2-1	15170-98810	•DIAPHRAGM SET	1	1	model G/J
2-2	15170-98100	•DIAPHRAGM SET	1	1	model VZ
3	15251-98101	•SCREW	4	4	
4	15251-98100	••SCREW	4	4	to 15251-98101
5	15252-98100	••LOCK WASHER	4	4	to 15251-98101
6	09343-05137	HOSE, fuel (DT8 : pump to carburetor L:500 → 270) (DT5 : pump to carburetor L:500 → 240)	1	1	
7	09343-05137	HOSE, fuel (connector to filter L:500 → 36)	1	1	
8	09343-05137	HOSE, fuel (filter to pump L:500 → 195)	1	1	
9	15410-98500	FILTER, fuel	1	1	Ref.No.18→DT8 E9,E13
10-1	65720-98501	PLUG, fuel connector	1	-	to 65720-98502,model G
10-2	65720-98502	PLUG, fuel connector	1	1	to 65720-98520
10-3	65720-98520	PLUG, fuel connector	1	1	(SUS)
11	08310-22108	NUT	1	1	
12	08321-21108	LOCK WASHER	1	1	DT5G DT8 (model G,J,VZ)
13	09401-09402	CLIP, fuel hose	6	6	
14	15311-98100	HOSE, vacuum	1	1	
15-1	09400-14301	CLAMP, vacuum hose (14φ)	2	-	DT5G to 09400-13302
15-2	09400-13302	CLAMP, vacuum hose (13φ)	2	2	
16	01517-06208	BOLT	2	2	
17	13635-98500	GUIDE, choke lod	1	-	
18	15410-93400	FILTER, fuel	-	1	E9,E13,E40
19	15416-93400	•PACKING	-	1	
20	15415-93400	•O RING	-	1	
21	15412-93400	•STRAINER	-	1	
22	15413-93400	•CUP	-	1	
23	15421-98100	BRACKET, fuel filter	-	1	
24	08321-21088	LOCK WASHER	-	1	
25	08310-22088	NUT	-	1	

FIG. 12



FIG. 12 FUEL PUMP

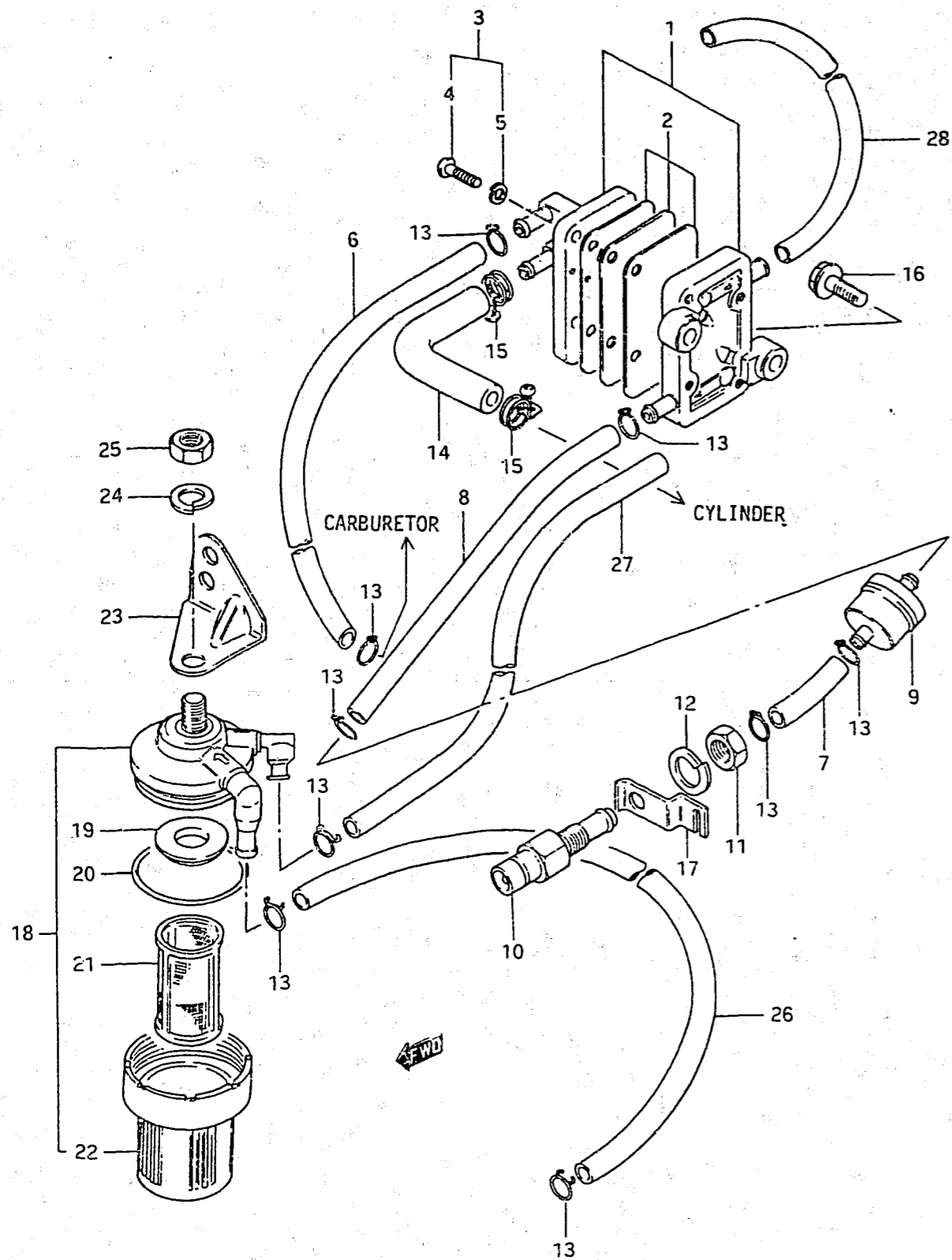

Ref. No.	Part No.	Description	Q'ty		Remarks
			5	8	
26	09343-05137	HOSE, fuel (connector to filter L:500 → 350)	-	1	E9, E13, E40
27	09343-05137	HOSE, fuel (filter to pump L:500 → 270)	-	1	E9
28	09343-05137	HOSE, fuel (pump to carburetor L:500 → 270)	-	1	E13

FIG. 13

C - 10

FIG. 13 WATER PUMP

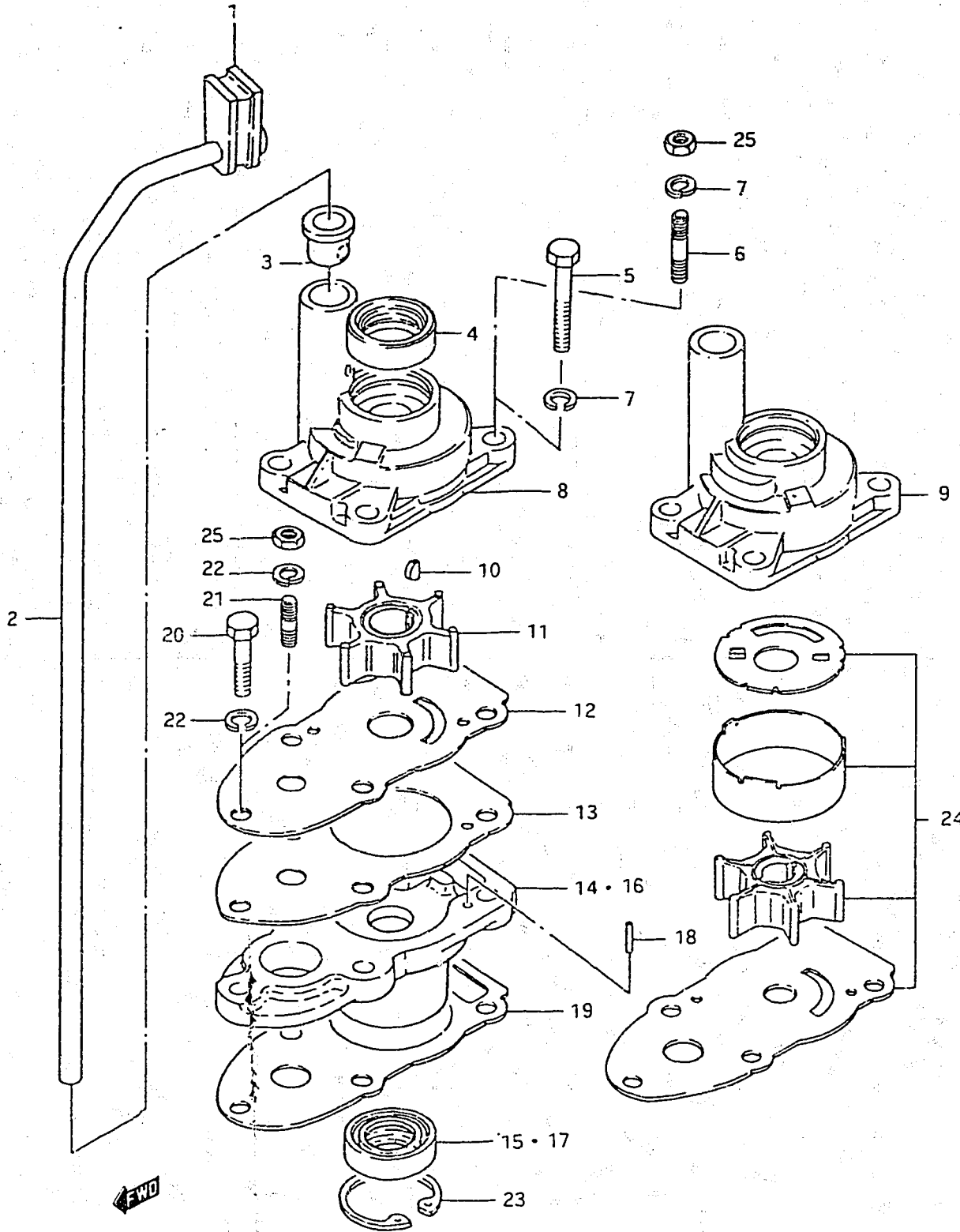

Ref. No.	Part No.	Description	Q'ty	Remarks
1	17563-98500	GROMMET, water tube	1	
2-1	17561-98510	TUBE, water (S type)	1	
2-2	17561-98520	TUBE, water (L type)	1	
3	17415-98500	BUSHING, water pump	1	
4	09289-10002	OIL SEAL, pump case	1	
5	09100-06022	BOLT	4	model G
6	09108-06025	STUD BOLT	4	
7	09162-06001	LOCK WASHER	4	
8-1	17411-98503	CASE, water pump	1	model G/J
8-2	17411-98504	CASE, water pump	1	model VZ
9	17411-98100	CASE, water pump	1	E9, E40
10	09420-03002	KEY, pump impeller	1	
11-1	17461-98401	IMPELLER, water pump	1	model G to 17461-98402
11-2	17461-98402	IMPELLER, water pump	1	model J/VZ
12-1	17471-98501	PLATE, pump case lower	1	to 17471-98502 model G, J
12-2	17471-98502	PLATE, pump case lower	1	have drain hole (φ2.5) model J, VZ
13	17472-98501	GASKET, pump plate	1	
14	56131-98501	HOUSING, driveshaft bearing	1	to 56130-98501
15	09289-10005	OIL SEAL, driveshaft lower	1	model G
16	56130-98501	HOUSING, drive shaft	1	S, L type
17	09289-10005	OIL SEAL, driveshaft lower	1	model J/VZ
18	09202-04008	DOWEL PIN	2	
19	56132-98500	GASKET, bearing housing	1	
20	09100-06047	BOLT	1	model G
21	09108-06032	STUD BOLT	1	
22	09162-06001	LOCK WASHER	1	
23	08331-41309	CIRCLIP, bearing housing	1	
24-1	17400-98850	WATER PUMP REPAIR KIT	1	G E9, to 17400-98851
24-2	17400-98851	WATER PUMP REPAIR KIT	1	G E9
24-3	17400-98853	WATER PUMP REPAIR KIT	1	J E9
24-4	17400-98100	WATER PUMP REPAIR KIT	1	VZ E-10
25	09140-06004	NUT, water pump case	5	

FIG. 14

D - 2

FIG. 14 STARTER DT5 (G/J/VZ), DT8 (G/J)

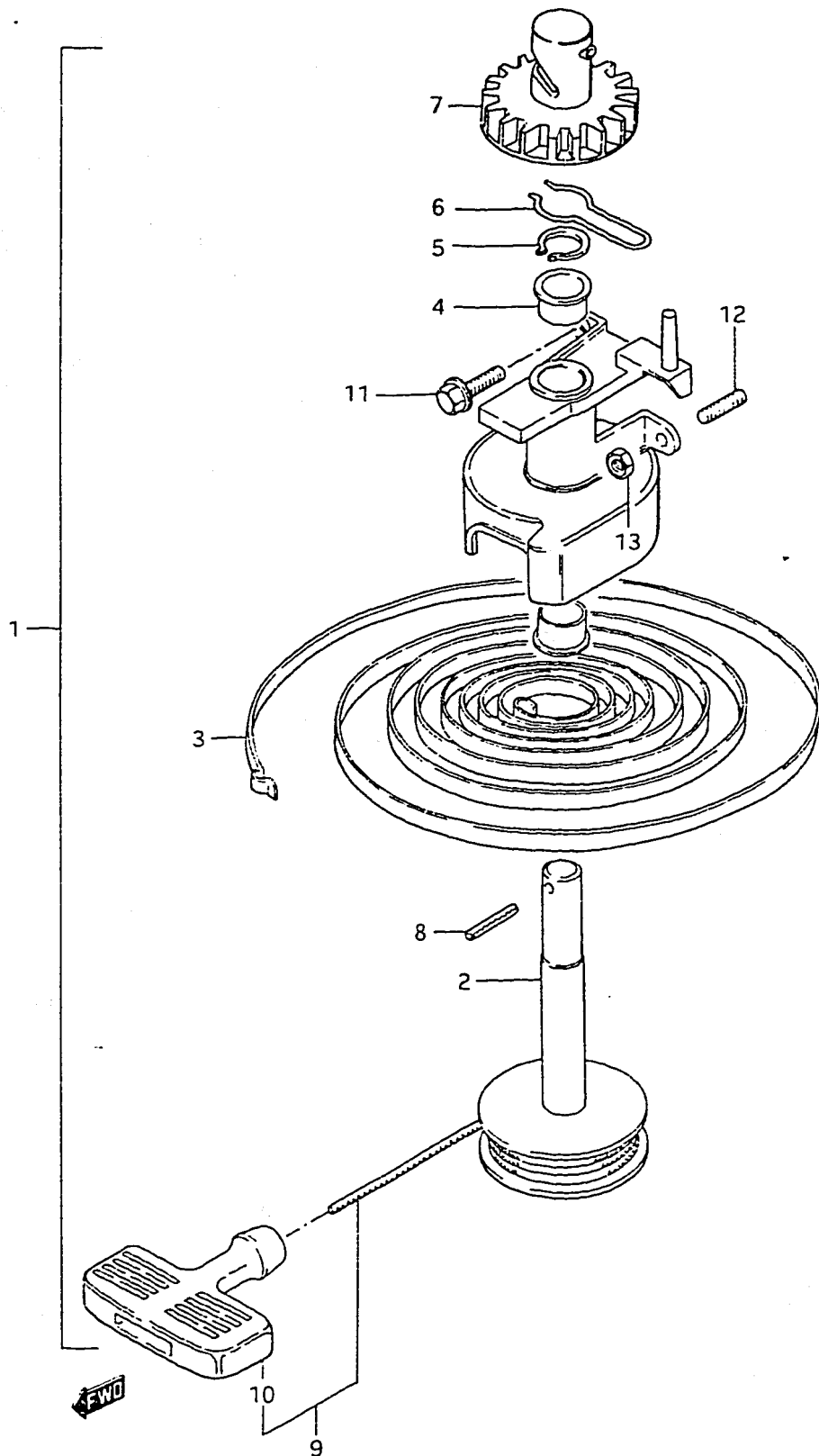

Ref. No.	Part No.	Description	Q'ty		Remarks
			5	8	
1	18100-98100-291	STARTER ASSY, recoil	1	1	
2	18121-98100	•REEL, starter	1	1	
3	18142-98300	•SPRING, recoil	1	1	
4-1	18522-98300	•BUSH, starter	2	2	model G
4-2	18253-98300	•BUSH, starter	2	2	from 18522-98300
5-1	18524-98301	•CIRCLIP, starter	1	1	
5-2	18255-98301	•CIRCLIP, starter	1	1	from 18524-98301
6-1	18541-98100	•SPRING, friction	1	1	
6-2	18271-98100	•SPRING, friction	1	1	
7-1	18531-98100	•PINION, starter	1	1	
7-2	18261-98100	•PINION, starter	1	1	from 18531-98100
8-1	18525-98100	•PIN, starter	1	1	
8-2	18344-98100	•PIN, starter	1	1	from 18525-98100
9-1	18170-98100	•GRIP ASSY, starter	1	1	
9-2	18200-98100	•GRIP ASSY, starter	1	1	from 18170-98100
10-1	18210-98001	••GRIP	1	1	
10-2	18210-93001	••GRIP	1	1	from 18210-98001
11-1	01517-06168	BOLT	3	2	
11-2	01517-06168	BOLT	2	1	
12	01421-06128	STUD BOLT	1	1	model J, DT5VZ
13	08316-26068	NUT	1	1	

FIG. 15 (D-3, 4) : DT8G (E3, E28), DT8J E28, DT8VZ
 FIG. 16 (D-5) : VZ (E13, E40)

FIG. 15

D - 3

FIG. 15 STARTER (DT8G (E3, E28), DT8J E28, DT8VZ)
Q'ty

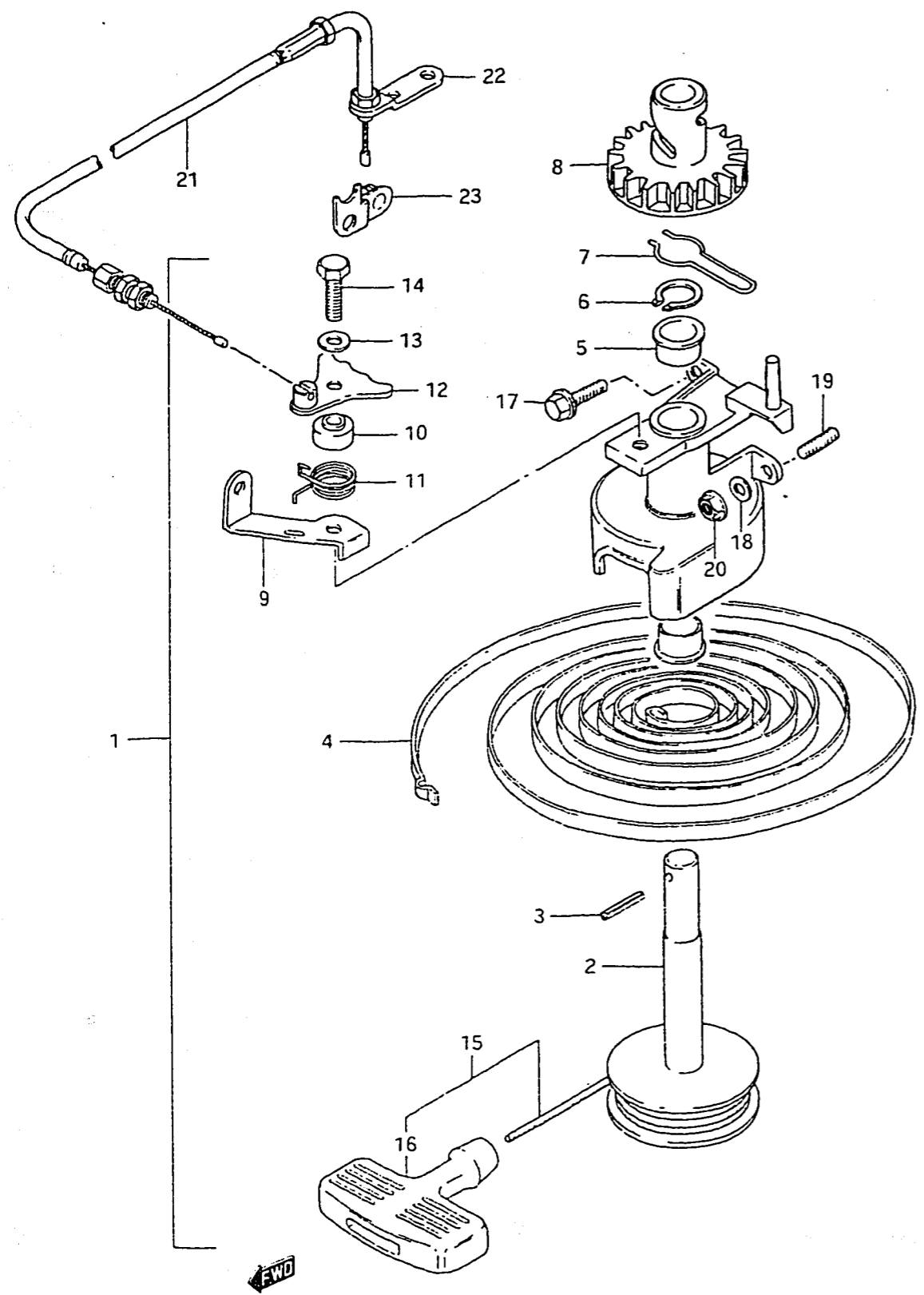

Ref. No.	Part No.	Description	Q'ty	Remarks
1	18100-98110-291	STARTER ASSY, recoil	1	
2	18121-98100	•REEL, starter	1	
3-1	18525-98100	•PIN, starter	1	model G
3-2	18344-98100	•PIN, starter	1	from 18525-98100
4	18142-98300	•SPRING, recoil	1	
5-1	18522-98300	•BUSHING, starter	2	
5-2	18253-98300	•BUSHING, starter	2	from 18522-98300
6-1	18524-98301	•CIRCLIP, starter	1	
6-2	18255-98301	•CIRCLIP, starter	1	from 18524-98301
7-1	18541-98100	•SPRING, friction	1	
7-2	18271-98100	•SPRING, friction	1	from 18541-98100
8-1	18531-98100	•PINION, starter	1	
8-2	18261-98100	•PINION, starter	1	from 18531-98100
9-1	18641-98101	•HOLDER, cable	1	
9-2	18291-98101	•HOLDER, cable	1	from 18641-98101
10-1	18553-98100	•SPACER	1	
10-2	18283-98100	•SPACER	1	from 18553-98100
11-1	18554-98100	•SPRING, return	1	
11-2	18284-98100	•SPRING, return	1	from 18554-98100
12-1	18550-98101	•STOPPER	1	
12-2	18280-98101	•STOPPER	1	from 18550-98101
13-1	18154-98100	•WASHER	1	
13-2	18335-98100	•WASHER	1	from 18154-98100
14-1	18153-98100	•BOLT	1	
14-2	18332-98100	•BOLT	1	from 18153-98100
15-1	18170-98100	•GRIP ASSY, starter	1	
15-2	18200-98100	•GRIP ASSY, starter	1	from 18170-98100
16-1	18210-98001	•GRIP	1	
16-2	18210-93001	•GRIP	1	from 18210-98001
17-1	01517-06168	BOLT	2	
17-2	01517-06168	BOLT	1	

FIG. 14 (D-2) : DT5 (G/J/VZ), DT8 (G/J)
FIG. 16 (D-5) : VZ (E13, E40)

FIG.15

D - 4

FIG.15 STARTER (DT8G (E3, E28), DT8J E28, DT8VZ)
Q'ty

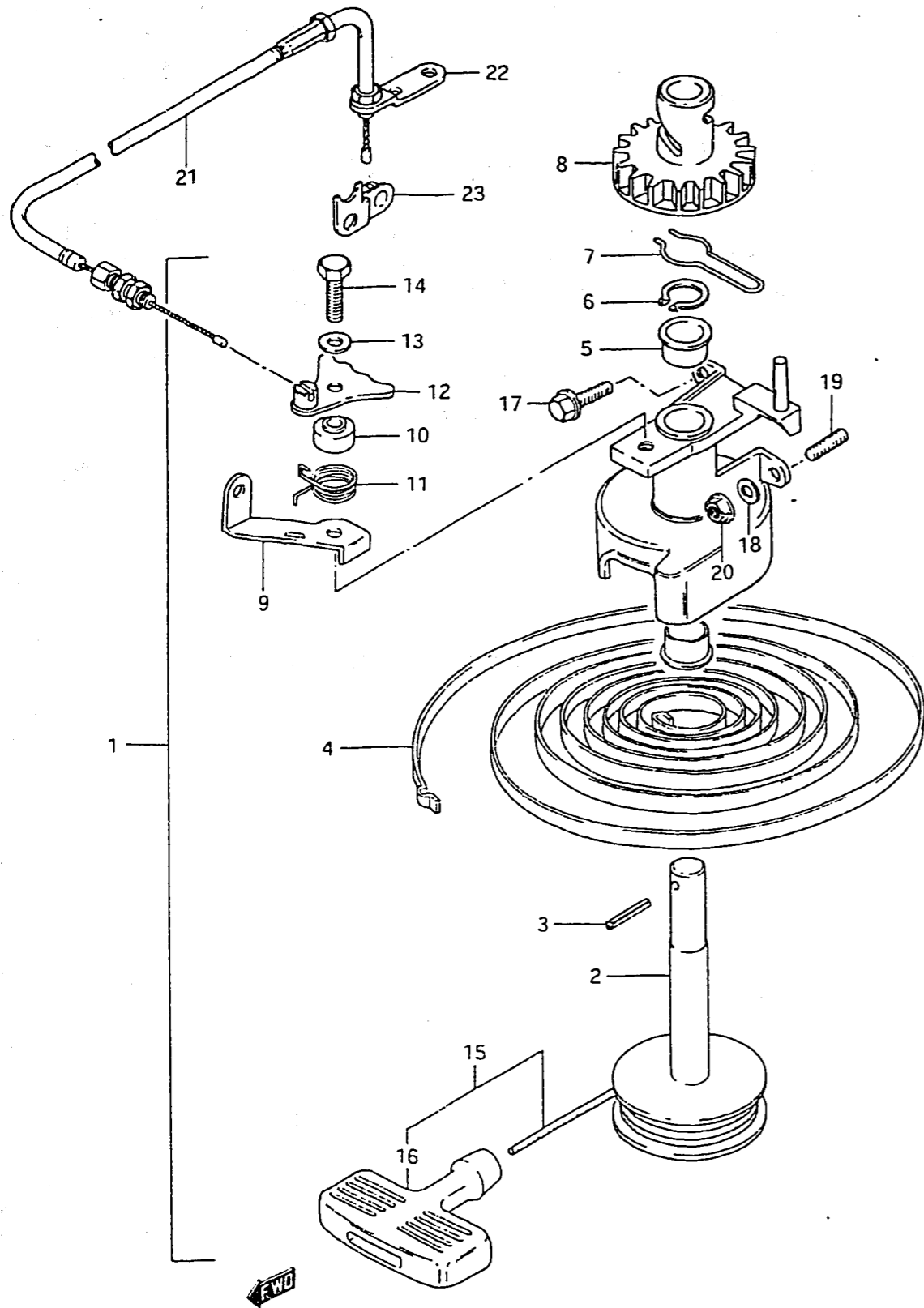

Ref. No.	Part No.	Description	Q'ty	Remarks
18	09160-05010	WASGER	1	model VZ
19	01421-06128	STUD BOLT	1	
20	08316-26068	NUT	1	
21	18630-98100	CABLE ASSY, inter lock	1	
22	13642-98100	HOLDER, cable	1	
23	18650-98100	ARM, inter lock	1	

FIG.14 (D-2) : DT5 (G/J/VZ), DT8 (G/J)
FIG.16 (D-5) : VZ (E13, E40)

FIG.16

D - 5

21

FIG.16 STARTER, model VZ (E13, E40)

Q'ty

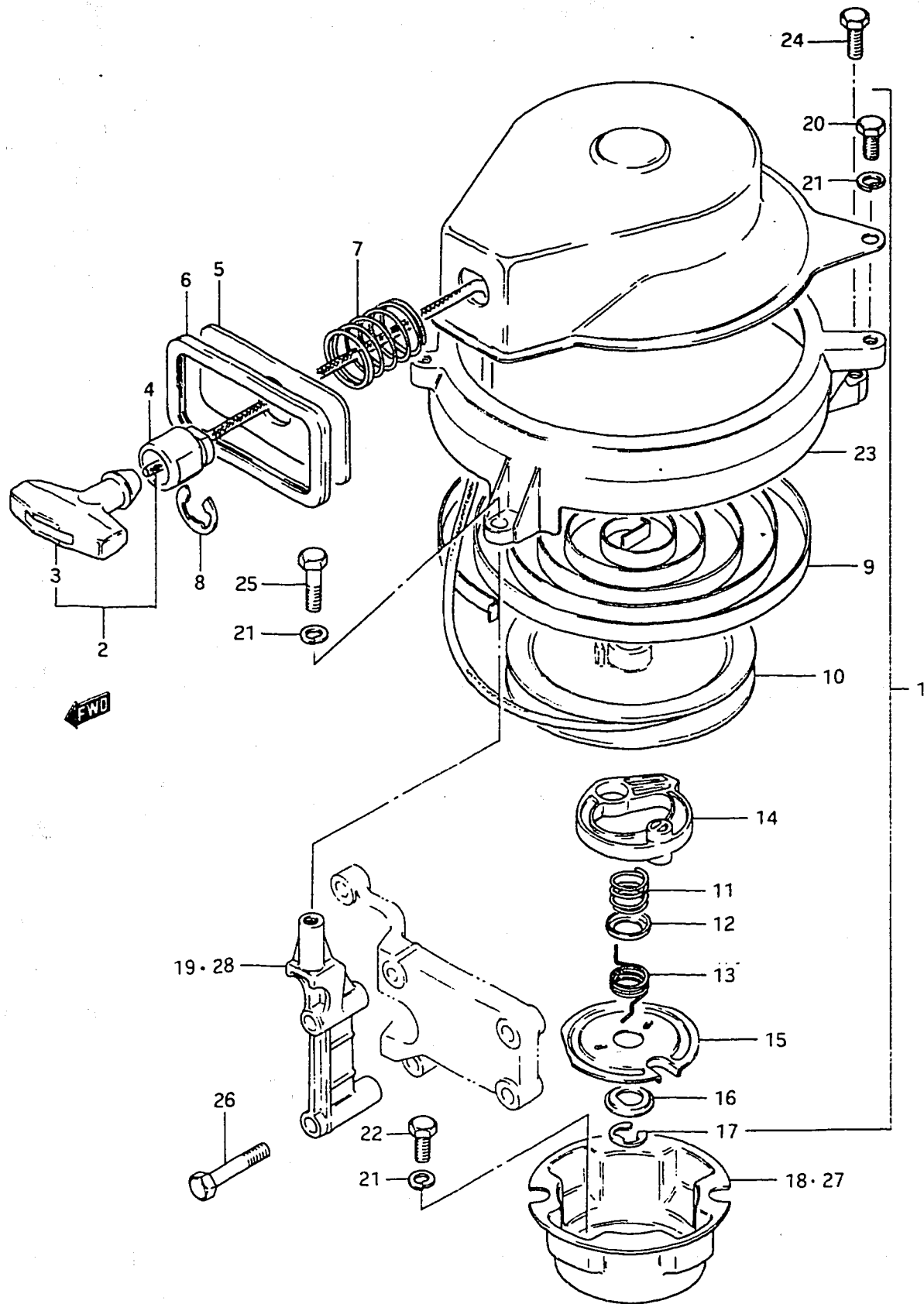

Ref. No.	Part No.	Description	5/8	Remarks
1	18100-98120-291	STARTER ASSY, recoil	1	
2	18200-98310	GRIP ASSY, starter	1	
3	18210-93500	GRIP	1	
4	18181-98310	GUIDE, rope	1	
5	18191-98120	DEFINER	1	
6	18192-93000	SEAL RUBBER, defencer	1	
7	18196-98120	SPRING	1	
8	18183-93400	CIRCLIP	1	
9	18142-98310	SPRING, recoil	1	
10	18121-98310	REEL	1	
11	18153-98310	SPRING, friction	1	
12	18157-98320	COVER, spring	1	
13	18155-98310	SPRING, return	1	
14	18131-98310	RATCHET	1	
15	18151-98320	PLATE, friction	1	
16	18335-98310	WASHER	1	
17	18178-98310	CIRCLIP	1	
18	18411-98100	CUP, starter	1	DT8VZ
19	18711-98100-01J	BRACE, recoil starter	1	
20	01107-06128	BOLT, recoil starter	3	
21	08321-21068	LOCK WASHER	9	
22	01107-06128	BOLT, starter cup	3	
23	14312-98100-01J	COVER, magneto	1	
24	01107-06208	BOLT	1	
25	01107-06358	BOLT	2	
26	01517-06458	BOLT, brace	1	DT5VZ
27	18411-98500	CUP, starter	1	DT5VZ
28	18711-98500-01J	BRACE, recoil starter	1	

FIG.14 (D-2) : DT5 (G/J/VZ), DT8 (G/J)
 FIG.15 (D-3, 4) :DT8G (E3, E28), DT8J (E28), DT8VZ

FIG. 17

D - 6

FIG. 17 CLUTCH LEVER

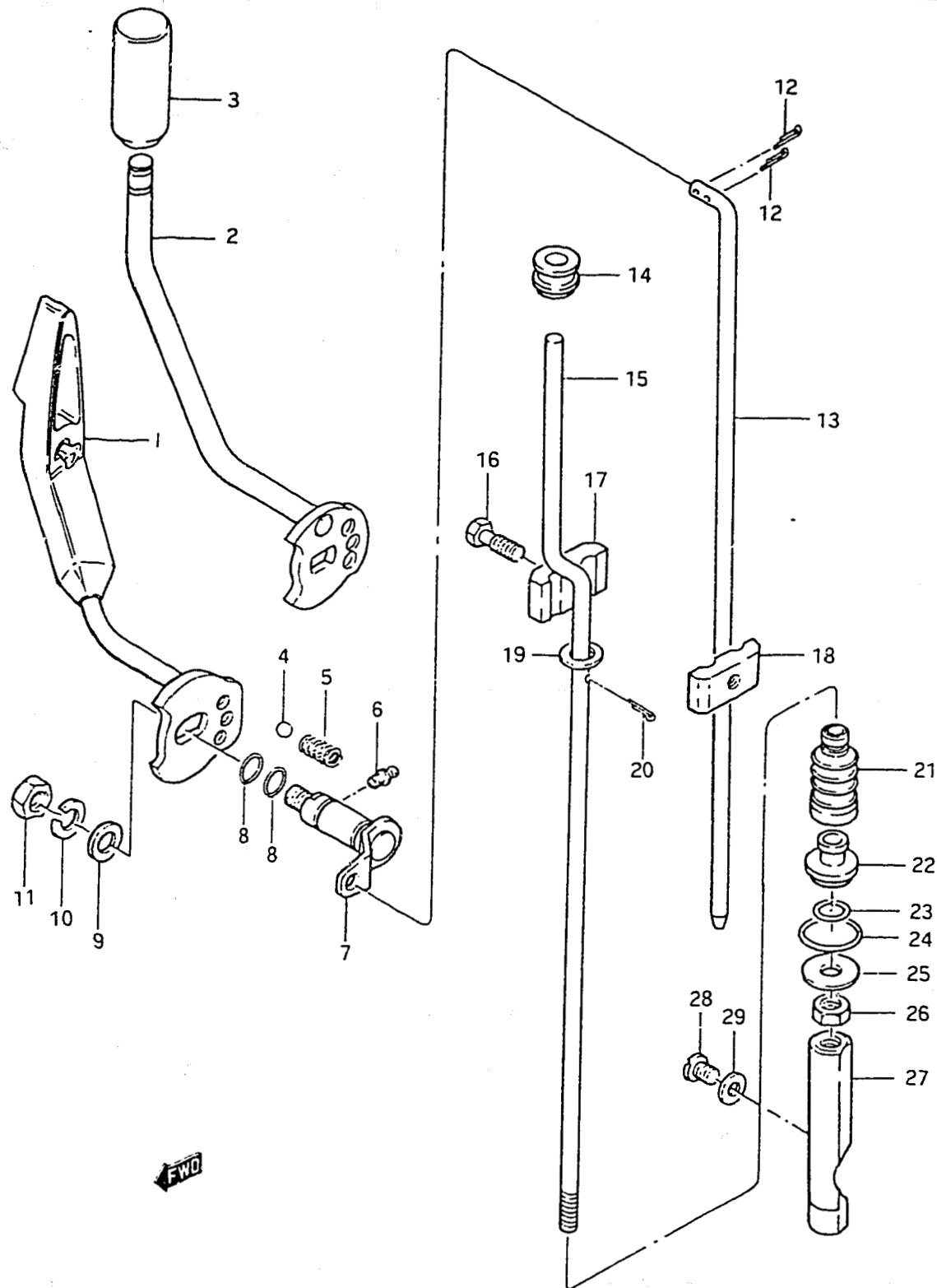

Ref. No.	Part No.	Description	Q'ty	Remarks
			5/8	
1	21110-98101-01J	LEVER, clutch	1	
2	21110-98502	LEVER, clutch	1	E9, E13, E40
3	21141-98500	KNOB	1	E9, E13, E40
4	09260-10003	BALL, clutch notch	1	
5	09440-07021	SPRING, clutch notch	1	
6	22511-99000	GREASE NIPPLE, clutch	1	
7-1	21210-98501	SHAFT, clutch lever	1	model G to 21210-98502
7-2	21210-98502	SHAFT, clutch lever	1	
8	09280-09003	O RING, clutch lever shaft	2	
9	09160-08015	WASHER	1	
10	09162-08003	LOCK WASHER	1	
11	09140-08003	NUT	1	
12	09204-01001	COTTER PIN, clutch rod	2	
13-1	23111-98510	ROD, clutch (S type)	1	
13-2	23111-98520	ROD, clutch (L type)	1	
14-1	09305-06006	BUSHING, shifting rod	1	to 09305-06008, model G
14-2	09305-06008	BUSHING, shifting rod	1	
15-1	25111-98510	ROD, shifting (S type)	1	
15-2	25111-98520	ROD, shifting (L type)	1	
16	09128-06014	BOLT, clutch rod	1	
17	23311-99001	CONNECTOR, clutch rod 1	1	
18	23321-99001	CONNECTOR, clutch rod 2	1	
19	09160-06015	WASHER, shifting rod	1	
20	09204-01001	COTTER PIN, shifting rod	1	
21	25222-93000	BOOT, shifting rod	1	
22	25211-98501	GUIDE, shifting rod	1	
23	09280-06004	O RING, shifting rod	1	
24	09280-16005	O RING, shifting rod guide	1	
25	08212-06201	WASHER, shifting rod guide	1	
26	08310-11068	NUT	1	
27	25311-93100	CAM, shifting	1	
28	09139-06003	SCREW, shifting cam stop	1	
29	09168-06002	GASKET, cam stop screw	1	

FIG. 20

D - 10

FIG. 20 DT8G MAGNETO

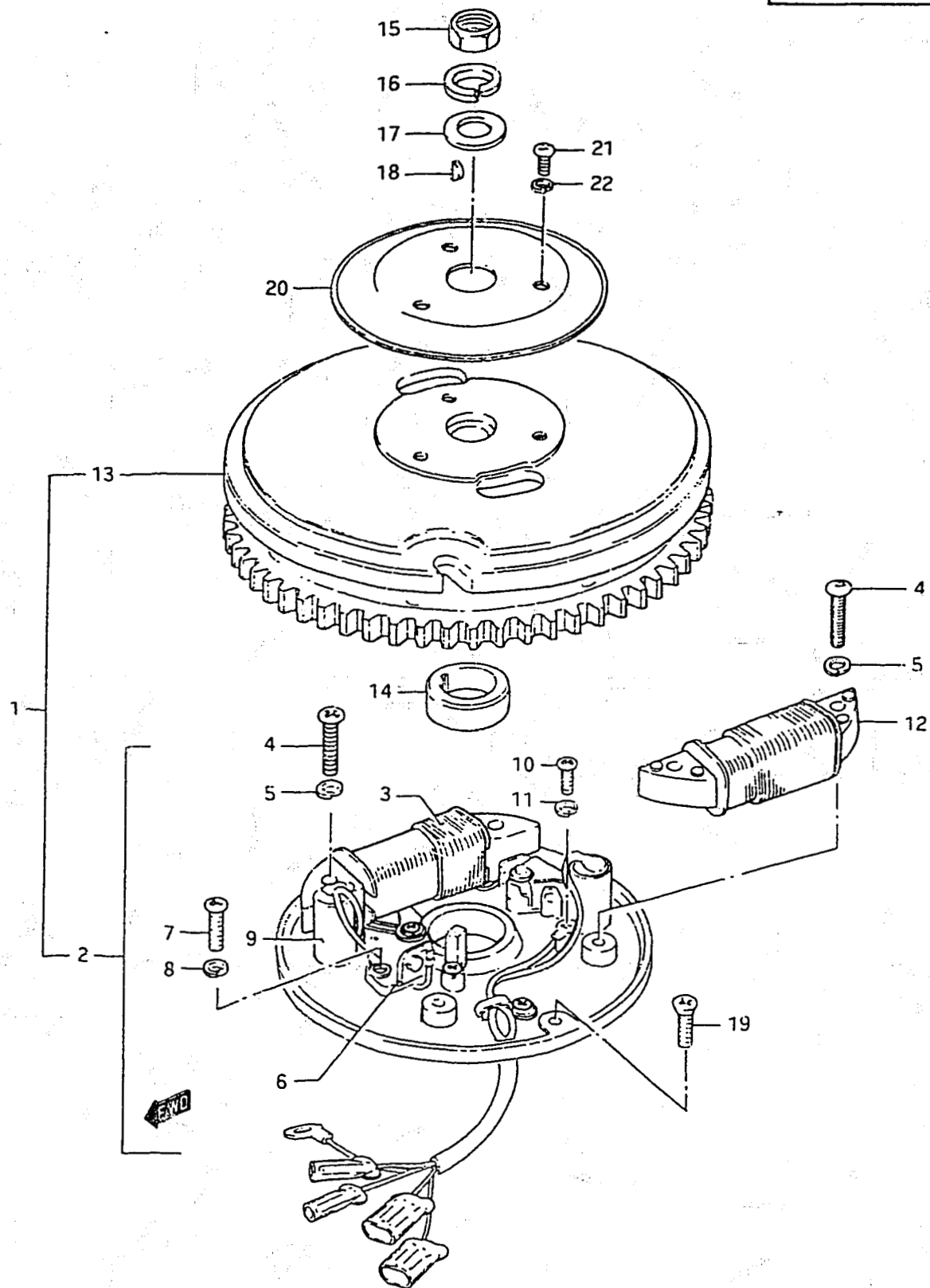

Ref. No.	Part No.	Description	Q'ty	Remarks
1	32100-98110	MAGNETO ASSY	1	
2-1	32101-98110	•STATER ASSY	1	
2-2	32101-98111	•STATER ASSY	1	from 32101-98110
3-1	32140-98100	••COIL ASSY, ignition	1	
3-2	32140-98101	••COIL ASSY, ignition	1	from 32140-98100
4	02112-05308	••SCREW	4	
5	08321-21058	••LOCK WASHER	4	
6	32240-98520	••POINT ASSY, contact	2	
7	02112-05168	••SCREW	2	
8	08321-21058	••LOCK WASHER	2	
9	32341-98520	••CONDENSER	2	
10	02112-04108	••SCREW	2	
11	08321-21048	••LOCK WASHER	2	
12	32120-98111	••COIL ASSY, lighting (12V,80W) (COIL ASSY, battery charging)	1	from 32120-98110
13	32102-98100	•ROTOR	1	
14-1	32490-98520	•CAM, contact	1	
14-2	32490-98521	•CAM, contact	1	from 32490-98520
15	08310-22128	NUT, magneto rotor	1	
16	08321-31128	LOCK WASHER, magneto rotor	1	
17	08322-11128	WASHER, magneto rotor	1	
18	08341-31039	KEY	1	
19	02122-05128	SCREW	2	
20	32725-98500	INSULATOR, magneto	1	
21	02112-06088	SCREW	3	
22	08321-21068	LOCK WASHER	3	

FIG. 18 (D-8) : DT5G
 FIG. 19 (D-9) : DT5 (J/VZ)
 FIG. 21 (D-12) : DT8J
 FIG. 23 (D-13) : DT8VZ

FIG. 21

D - 12

FIG. 21 DT8J MAGNETO

Q'ty

Ref. No.	Part No.	Description	Q'ty	Remarks
1	32100-98130	MAGNETO ASSY to (32101-98130)+(32102-98110)	1	
2	32101-98131	•STATER ASSY	1	from 32101-98130
3	32140-98110	••COIL ASSY, ignition	1	
4	02112-05308	••SCREW	2	
5	02112-05258	••SCREW	2	
6	08321-21058	••LOCK WASHER	4	
7	32150-98101	••SENSOR	1	from 32150-98100
8	02112-04108	••SCREW	2	
9	08321-21048	••LOCK WASHER	2	
10	32120-98111	••COIL ASSY, lighting (12V,80W)	1	COIL ASSY, battery charging
11-1	32102-98110	•ROTOR	1	
11-2	32102-98111	•ROTOR	1	from 32102-98110
12	08310-22128	NUT, magneto rotor	1	
13	08321-31128	LOCK WASHER	1	
14	08322-11128	WASHER	1	
15	08341-31039	KEY	1	
16	02122-05128	SCREW	2	
17	32725-98500	INSULATOR, magneto	1	
18	02112-06088	SCREW	3	
19	08321-21068	LOCK WASHER	3	

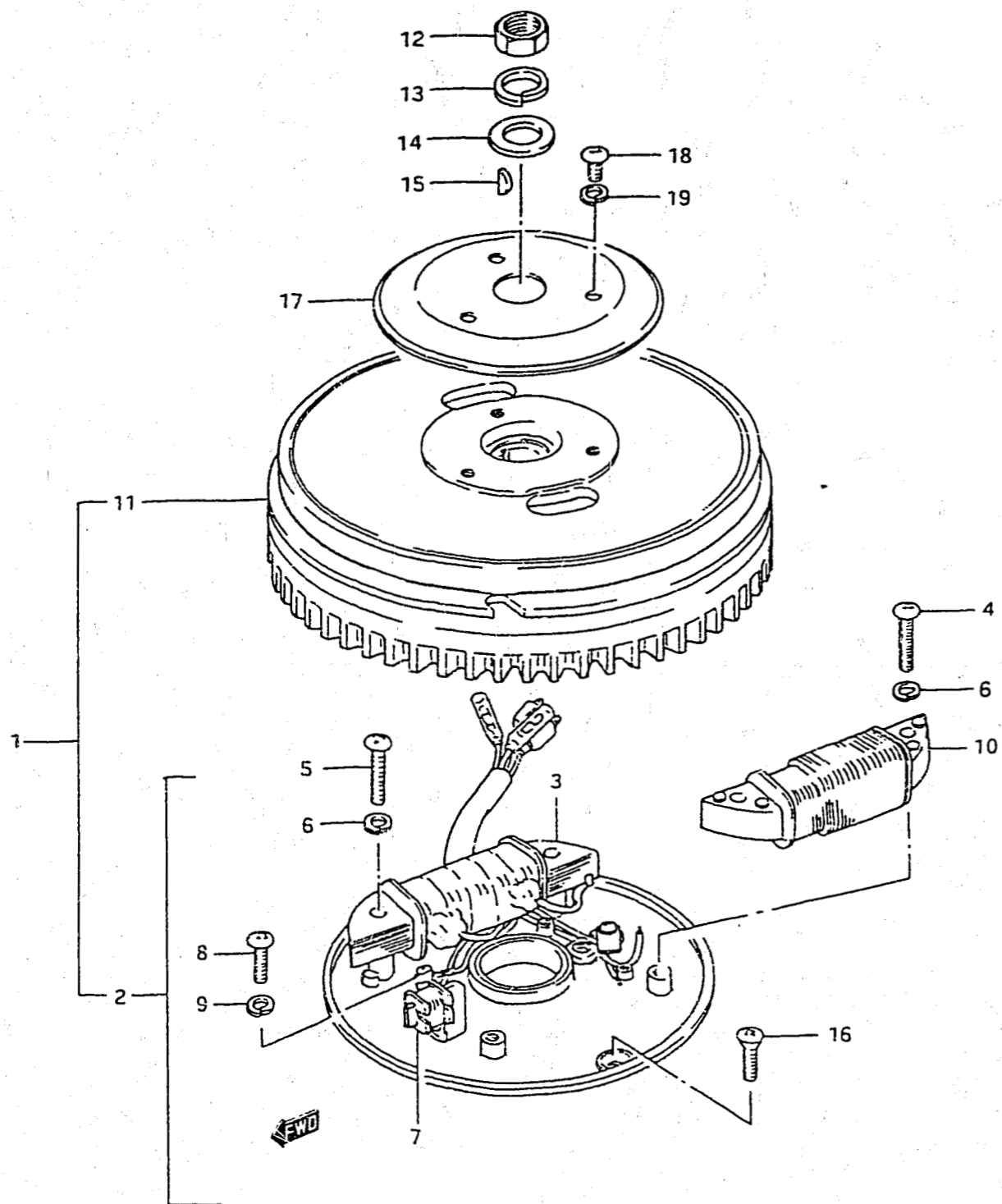
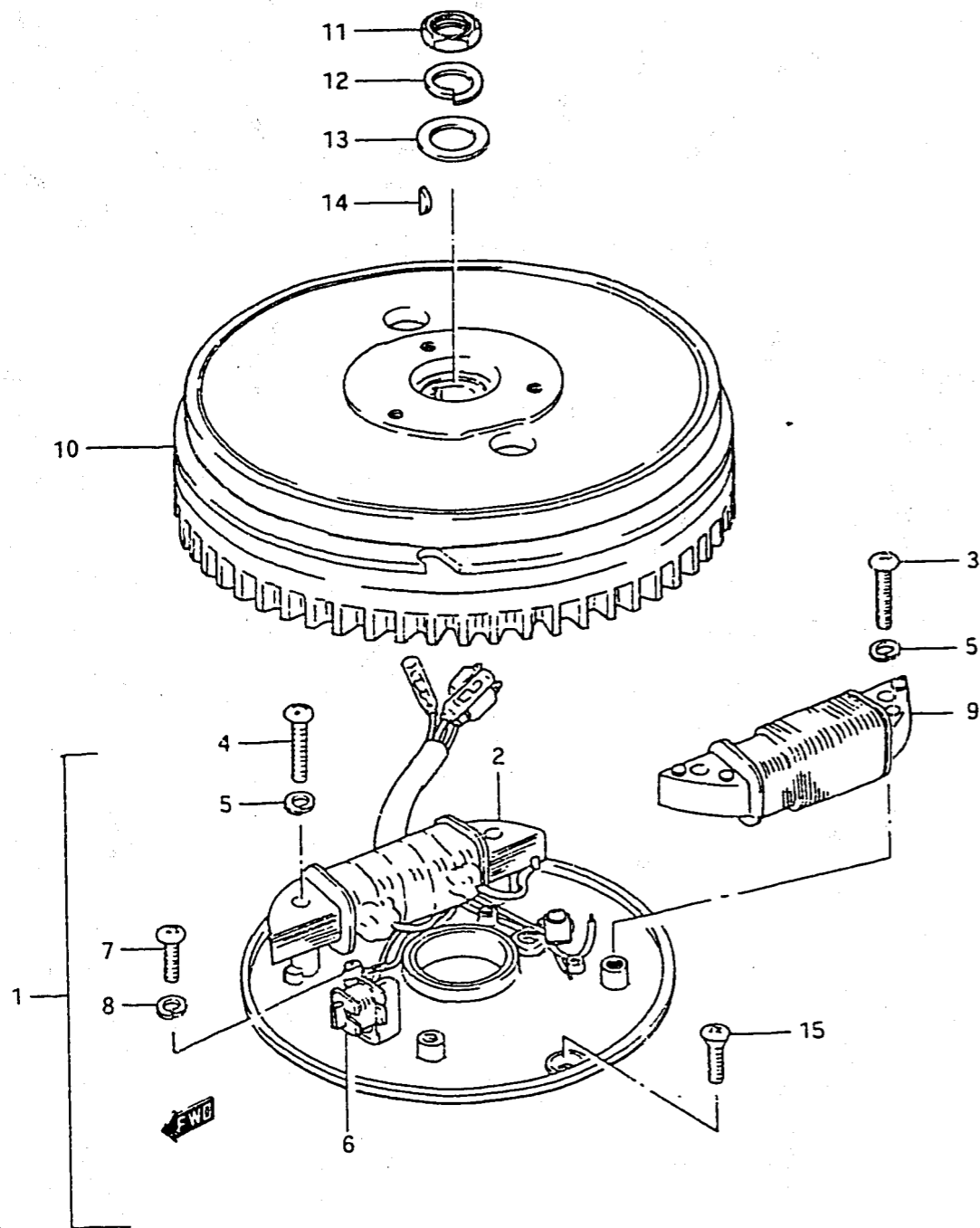

FIG. 18 (D-8) : DT5G
 FIG. 19 (D-9) : DT5 (J/VZ)
 FIG. 20 (D-10): DT8G
 FIG. 22 (D-13): DT8VZ

FIG. 22

D - 13

FIG. 22 DT8VZ MAGNETO



Ref. No.	Part No.	Description	Q'ty	Remarks
1	32101-98131	STATOR ASSY	1	from 32101-98130
2	32140-98110	·COIL ASSY, ignition	1	
3	02112-05308	·SCREW	2	
4	02112-05258	·SCREW	2	
5	08321-21058	·LOCK WASHER	4	
6	32150-98101	·SENCOR	1	from 32150-98100
7	02112-04108	·SCREW	2	
8	08321-21048	·LOCK WASHER	2	
9	32120-98111	·COIL ASSY, lighting (12V, 80W)	1	COIL ASSY, battery charging.
10	32102-98112	ROTOR	1	
11	08310-22128	NUT, magneto rotor	1	
12	08321-31128	LOCK WASHER	1	
13	08322-11128	WASHER	1	
14	08341-31039	KEY	1	
15	02122-05128	SCREW	2	

FIG. 18 (D-8) : DT5G
 FIG. 19 (D-9) : DT5J/VZ
 FIG. 20 (D-10): DT8G
 FIG. 21 (D-12): DT8J

FIG. 23

FIG. 23 ELECTRICAL

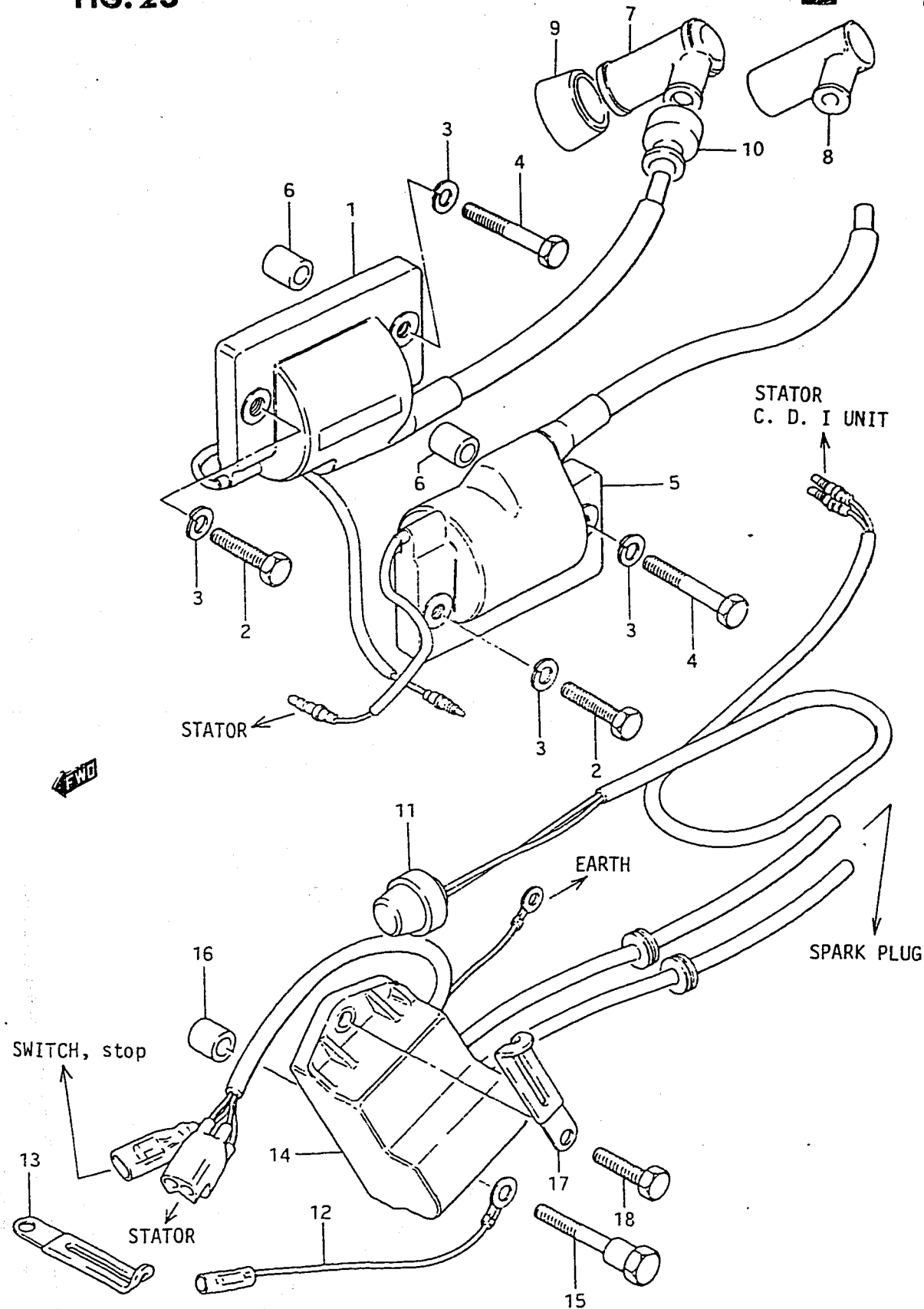

Ref. No.	Part No.	Description	Q'ty		Remarks
			5	8	
1	33410-98100	COIL ASSY, ignition upper	1	1	model G
2	01107-06308	BOLT, ignition coil LH	2	2	
3	08321-21068	LOCK WASHER	4	4	
4	01107-06458	BOLT, ignition coil RH	2	2	
5	33420-98100	COIL ASSY, ignition lower	1	1	
6	09180-06079	SPACER, ignition coil RH	2	2	
7	33510-22010	CAP, spark plug	2	2	G(E9, E13), J(E3, E9, E13) VZ(E13, E40)
8	33510-95510	CAP, spark plug	2	2	
9	33541-93310	SEAL, spark plug	2	2	
10	33542-98000	SEAL, high tension cord	2	2	
11	37800-93150	SWITCH ASSY, engine stop	1	1	
12	37801-98351	LEAD, stop switch	1	1	to 32900-98101 model J/VZ
13	09404-06401	CLAMP, switch wire	1	1	
14-1	32900-98100	CDI UNIT & IGNITION COIL	-	1	
14-2	32900-98101	CDI UNIT & IGNITION COIL	1	1	
15	09111-06030	BOLT, lower	1	1	
16	09180-06079	SPACER	1	1	
17	09404-06412	CLAMP, lead wire	1	1	
18	01107-06208	BOLT, upper	1	1	

FIG. 24

E - 3

29

FIG.24 CLAMP BRACKET (model G/J)

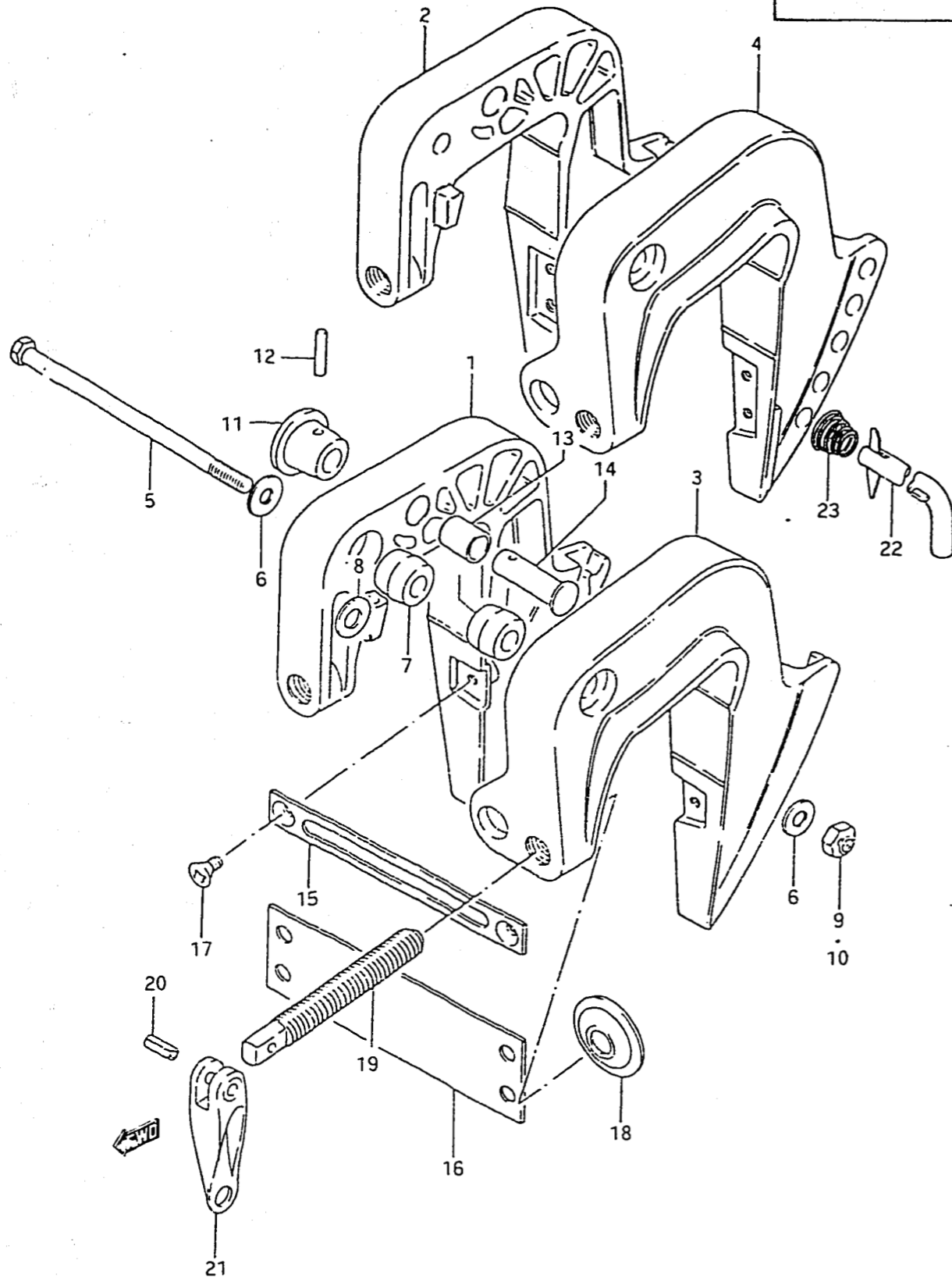

Ref. No.	Part No.	Description	Q'ty	Remarks
1-1	41111-98502-01J	BRACKET, clamp RH	1	to 41111-98503-01J model G
1-2	41111-98503-01J	BRACKET, clamp RH to (41111-98504-01J)+(41121-98503-01J)+(43111-98102-01J)+(09100-10148)+ (09160-10040) 2pcs + (09140-10015)+(09160-10050) 2pcs	1	
1-3	41111-98504-01J	BRACKET, clamp RH	1	to 41111-98505-01J model J
1-4	41111-98505-01J	BRACKET, clamp RH	1	
2-1	41111-98510-01J	BRACKET, clamp RH to (41111-98511-01J)+(41121-98511-01J)+(43111-98102-01J)+(09100-10148)+ (09160-10040) 2pcs + (09140-10015)+(09160-10050) 2pcs	1	G(E9, E13) E9, E13 from 41111-98511-01J
2-2	41111-98512-01J	BRACKET, clamp RH	1	
3-1	41121-98501-01J	BRACKET, clamp LH	1	to 41121-98502-01J model G
3-2	41121-98502-01J	BRACKET, clamp LH to (41121-98503-01J)+(41111-98504-01J)+(43111-98102-01J)+(09100-10148)+ (09160-10040) 2pcs + (09140-10015)+(09160-10050) 2pcs	1	
3-3	41121-98503-01J	BRACKET, clamp LH	1	to 41121-98504-01J model J
3-4	41121-98505-01J	BRACKET, clamp LH	1	
4-1	41121-98510-01J	BRACKET, clamp LH to (41121-98511-01J)+(41111-98511-01J)+(43111-98102-01J)+(09100-10148)+ (09160-10040) 2pcs + (09140-10015)+(09160-10050) 2pcs	1	G(E9, E13) E9, E13 from 41121-98511-01J
4-2	41121-98512-01J	BRACKET, clamp LH	1	
5-1	09100-08144	BOLT, swivel shaft (8x145)	1	model G for 41111-98502-01J, 41111-98503-01J, 41121-98501-01J, 41121-98502-01J, 41111-98510-01J, 41121-98510-01J
5-2	09100-10148	BOLT, swivel shaft (10x145)	1	
6-1	09160-08015	WASHER	2	for 41111-98504-01J, 41111-98505-01J, 41121-98503-01J, 41121-98505-01J, 41111-98511-01J & 41121-98511-01J
6-2	09160-10040	WASHER	2	
7	43321-96000	BUSHING, tilt friction	2	
8	09160-10050	WASHER, tilt friction	2	
9-1	09159-08018	NUT	1	
9-2	09140-10015	NUT (to 09159-10032)	1	
10	09159-10032	NUT	1	

FIG.25 (E-5) : model VZ

FIG. 24

E - 4

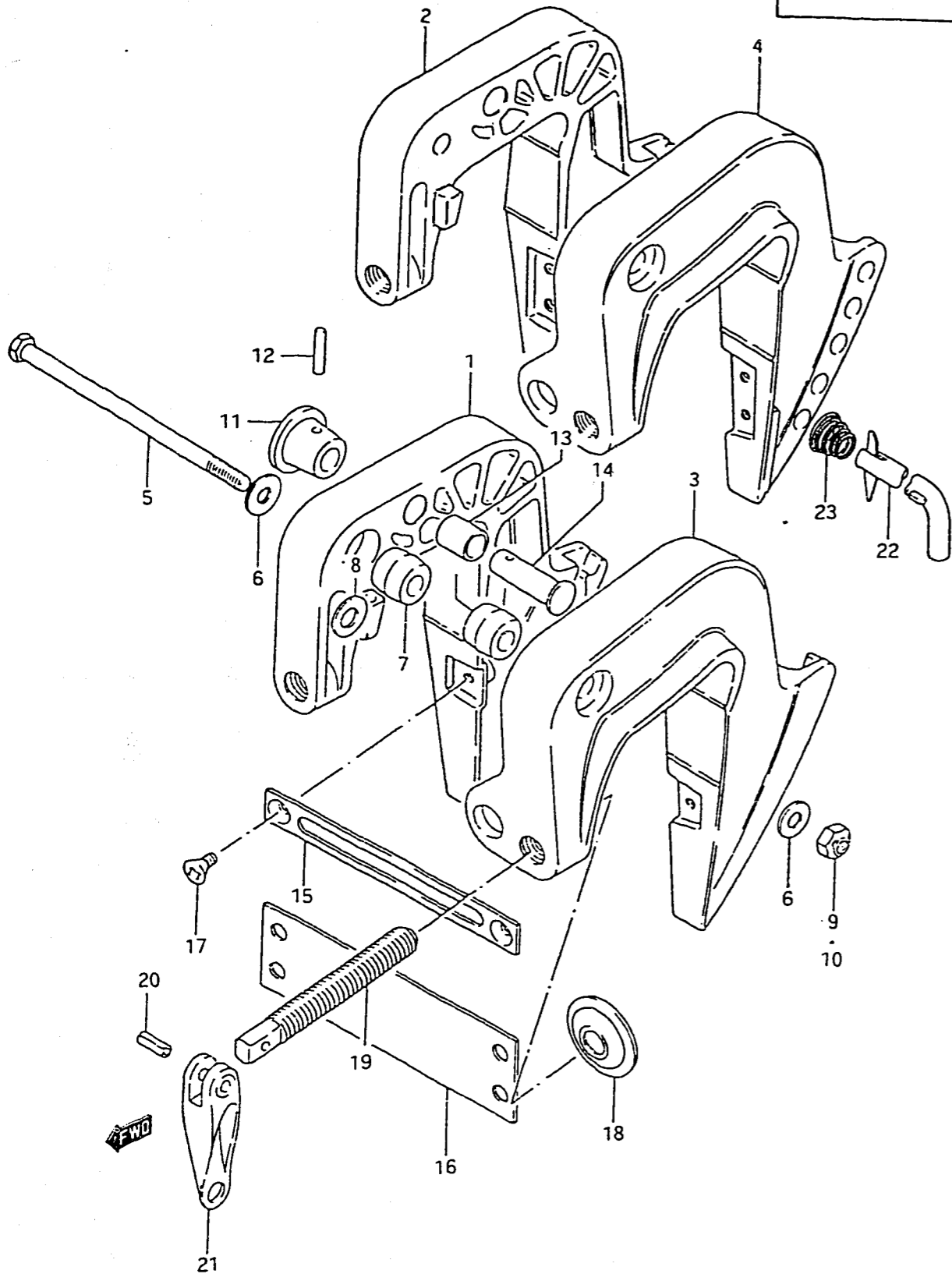

30

FIG.24 CLAMP BRACKET (model G/J)

Ref. No.	Part No.	Description	Q'ty		Remarks
			5/8		
11	41221-93001	KNOB, tilt stopper	1		
12	09205-03015	PIN, tilt stopper knob	1		
13	09300-12009	BUSHING, tilt stopper pin	1		
14	09200-12001	PIN, tilt stopper	1		
15	41311-98500	PLATE, clamp bracket	1		model G
16	41311-98100	PLATE, clamp bracket	1		
17-1	09125-06020	SCREW, clamp bracket	2		for 41311-98500
17-2	09125-06020	SCREW, clamp bracket	4		for 41311-98100
18	41213-98100	PLATE, clamp	2		
19	41211-98500	SCREW, clamp	2		
20	09205-05001	PIN, clamp handle	2		
21	41212-99000-01J	HANDLE, clamp	2		
22	45420-98100	PIN, tilt lock	1		E9, E13
23	09441-17001	SPRING, tilt lock pin	1		E9, E13

FIG.25 (E-5) : model VZ

FIG. 25

E - 5

31

FIG.25 CLAMP BRACKET (model VZ)

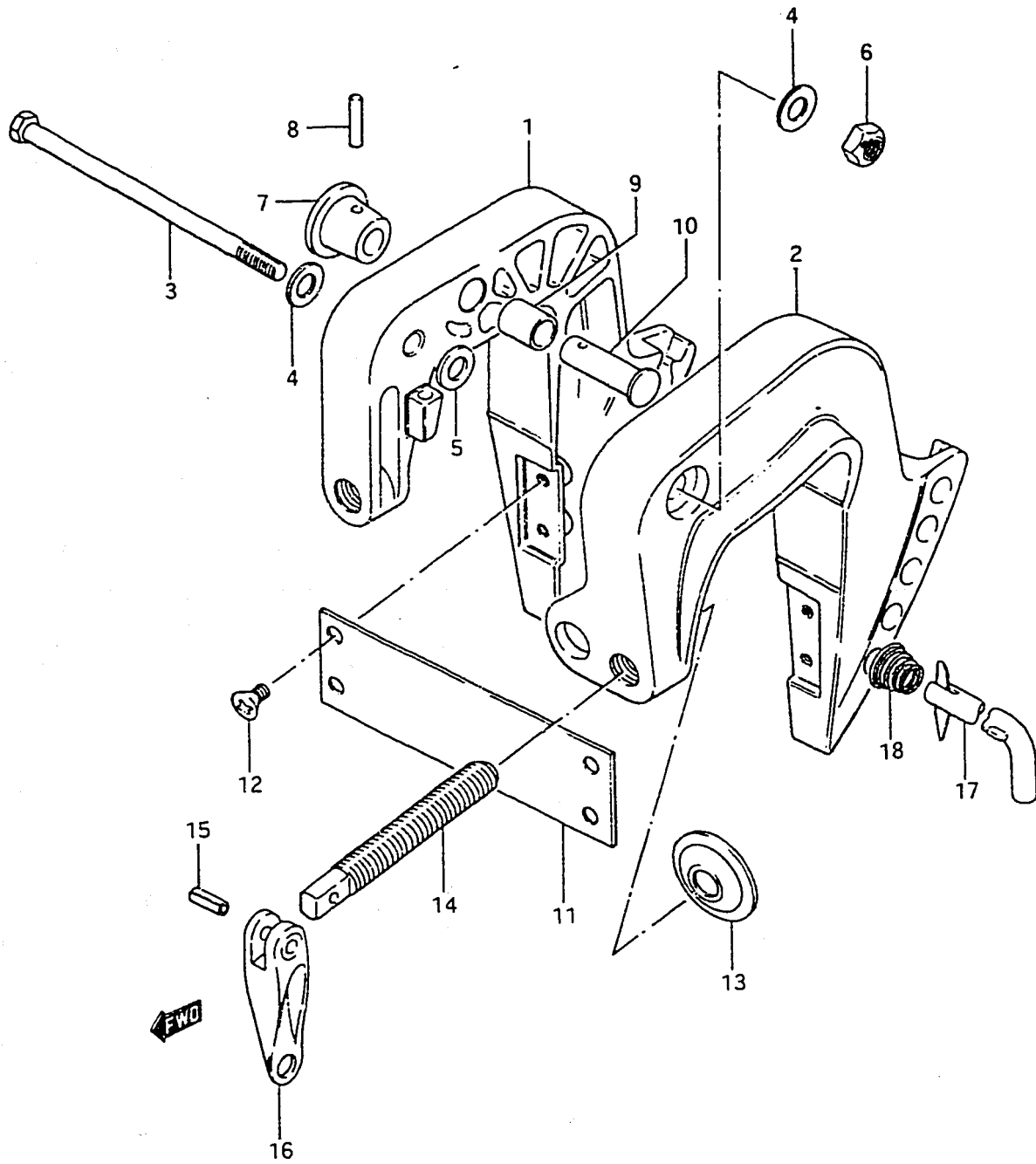

Ref. No.	Part No.	Description	Q'ty	Remarks
1	41111-98512-01J	BRACKET, clamp RH	1	
2	41121-98513-01J	BRACKET, clamp LH	1	
3	09100-10148	BOLT, swivel shaft (10x145)	1	
4	09160-10040	WASHER	1	
5	09160-10050	WASHER, tilt friction	2	
6	09159-10032	NUT	1	
7	41221-93001	KNOB, tilt stopper	1	
8	09205-03015	PIN, tilt stopper knob	1	
9	09300-12009	BUSHING, tilt stopper pin	1	
10	09200-12001	PIN, tilt stopper	1	
11	41311-98100	PLATE, clamp bracket	1	
12	09125-06020	SCREW, clamp bracket	4	
13	41213-98100	PLATE, clamp	2	
14	41211-98500	SCREW, clamp	2	
15	09205-05001	PIN, clamp handle	2	
16	41212-99000-01J	HANDLE, clamp	2	
17	45420-98100	PIN, tilt lock	1	E40
18	09441-17001	SPRING, tilt lock pin	1	E40

FIG.24 (E-3, 4) : model G/J

FIG.26

E - 6

FIG.26 SWIVEL BRACKET

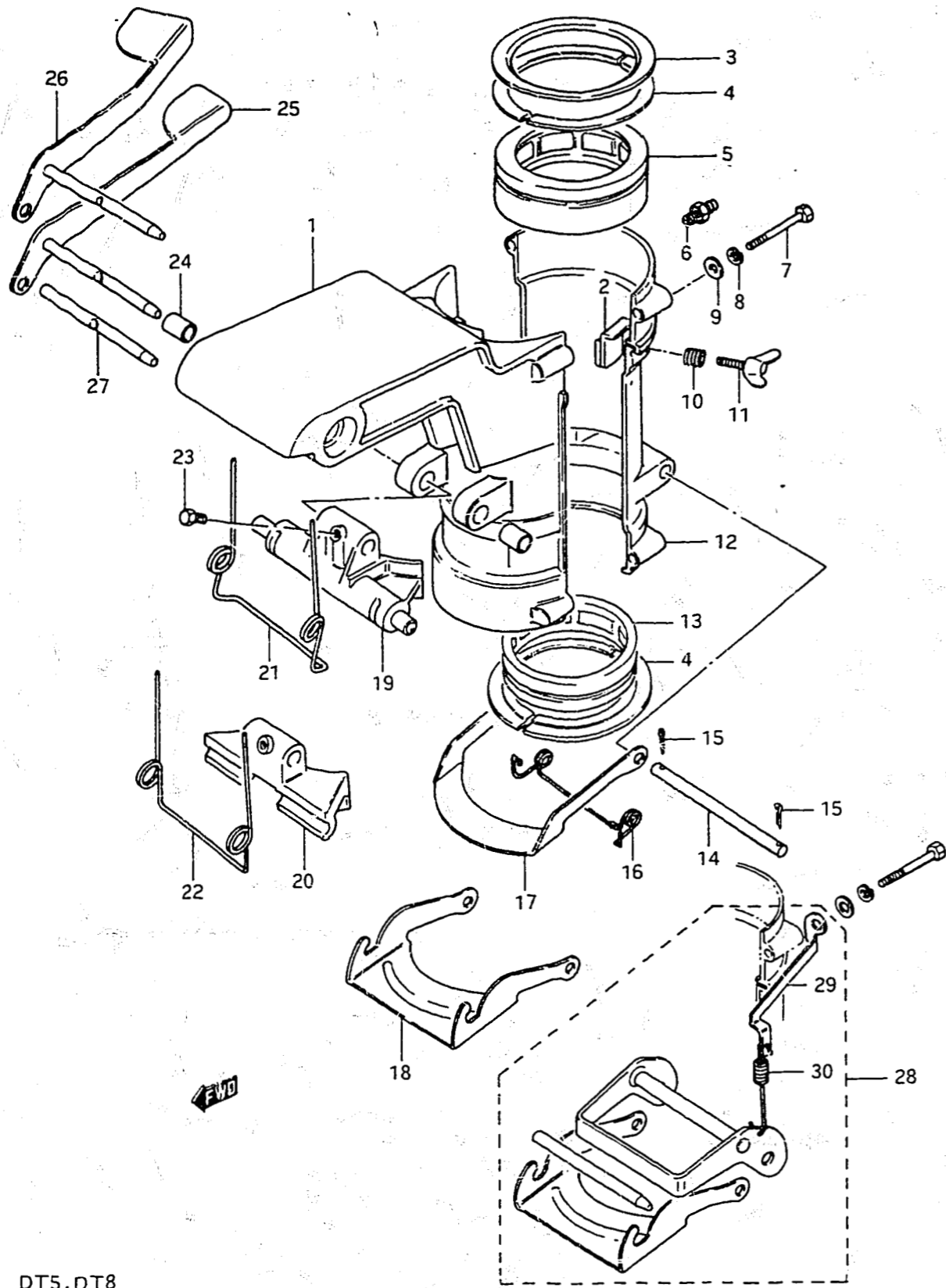

Q'ty

Ref. No.	Part No.	Description	5/8	Remarks
1-1	43111-98100-01J	BRACKET, swivel	1	to 43111-98101-01J model G
1-2	43111-98101-01J	BRACKET, swivel	1	
	to (43111-98102-01J)+(41111-98504-01J)+(41121-98503-01J)+ (09100-10148)+(09160-10040...2pcs)+(09140-10015)+(09160-10050...2pcs) (E9, E13).....to (43111-98102-01J)+(41111-98511-01J)+(41121-98511-01J)+ (09100-10148)+(09160-10040...2pcs)+(09140-10015)+ (09160-10050...2pcs)			
1-3	43111-98102-01J	BRACKET, swivel	1	
2-1	43410-98100	ADJUSTER, steering	1	DT5G
2-2	43410-98101	ADJUSTER, steering	1	
3-1	43712-98500	PLATE, steering upper	1	model G/J
3-2	43712-98501	PLATE, steering upper	1	model VZ
4	43713-98500	PIECE, steering bush	4	
5	43711-98100	BUSHING, steering upper	1	
6	22511-99000	GREASE NIPPLE	2	
7-1	09100-06035	BOLT, swivel bracket	4	model G/J
7-2	09100-06097	BOLT, swivel bracket	4	model VZ
8	09162-06001	LOCK WASHER	4	
9	09160-06015	WASHER	4	
10-1	09440-09009	SPRING, steering adjuster	1	L:13,model G
10-2	09440-09012	SPRING, steering adjuster	1	L:15
11	09119-06040	BOLT, steering adjuster	1	
12-1	43121-98100-01J	COVER, swivel bracket	1	model G/J
12-2	43121-98101-01J	COVER, swivel bracket	1	model VZ from 43121-98100-01J
13-1	43721-98502	BUSHING, steering lower	1	model G to 43721-98503
13-2	43721-98503	BUSHING, steering lower	1	
14	09200-08026	PIN, reverse lock arm	1	
15	09204-01001	COTTER PIN	2	
16	45212-98500	SPRING, reverse lock arm	1	
17	45231-98501	ARM, reverse lock arm	1	
18	45231-98100	ARM, reverse lock arm	1	E9,E13,E40

FIG. 26

E - 7

33

FIG. 26 SWIVEL BRACKET

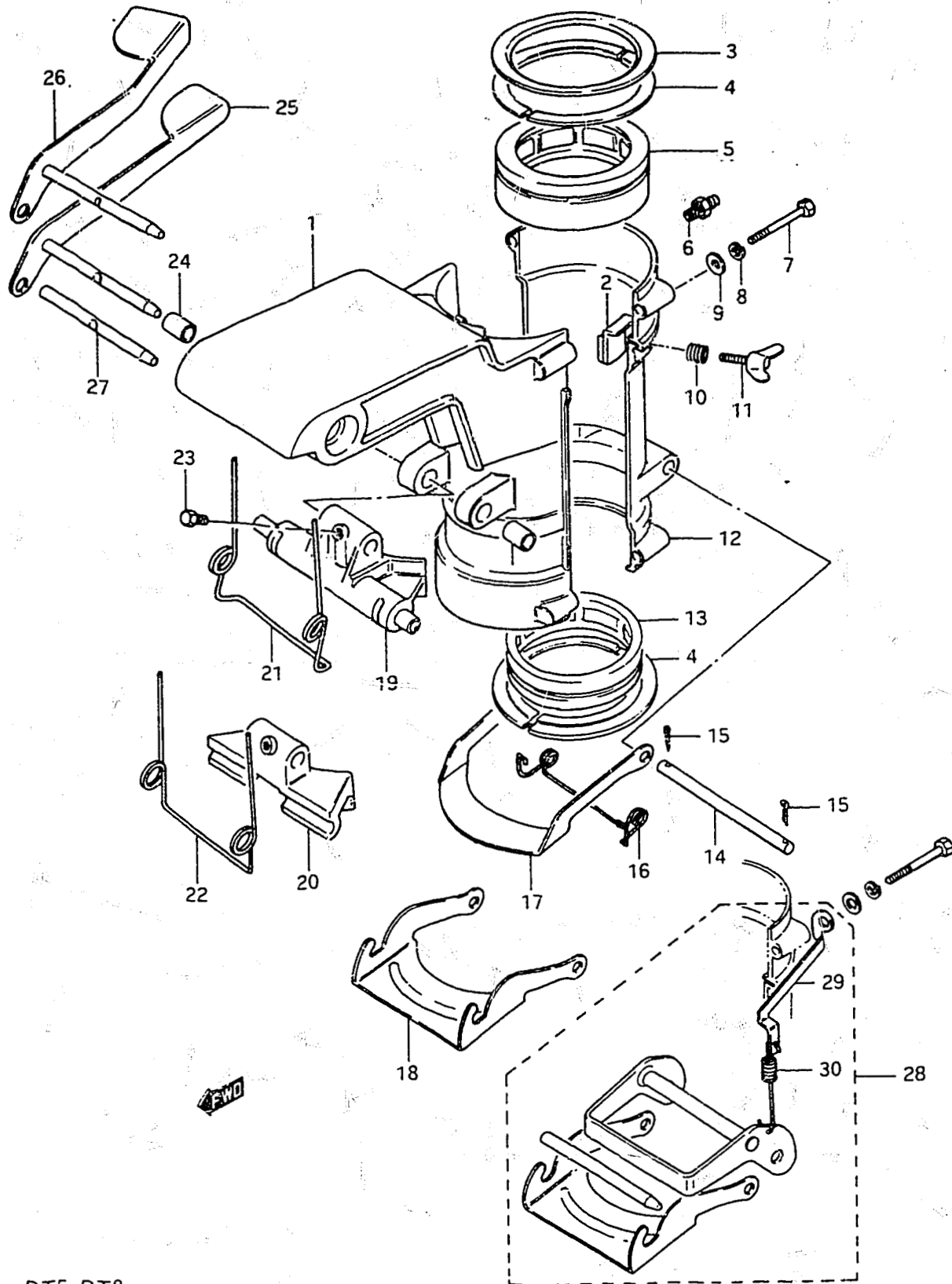

Ref. No.	Part No.	Description	Q'ty	5/8	Remarks
19-1	45411-98500-01J	BLOCK, thrust	1		model G to 45411-98501-01J
19-2	45411-98501-01J	BLOCK, thrust	1		model J/VZ
20	45411-98100-01J	BLOCK, thrust	1		E9, E13, E40
21	45211-98502	SPRING, rack lever	1		
22	45211-98100	SPRING, rack lever	1		E9, E13, E40
23	09139-05003	SCREW, rack lever	1		
24	09300-08005	BUSHING, rack lever	2		
25	45110-98500	LEVER, rack	1		model G to 45110-98501
26	45110-98501	LEVER, rack	1		
27	45112-98100	SHAFT, rack	1		E9, E13, E40
28	45700-98500	SHALLOW DRIVE ASSY	1	} OPT	
29	45713-98500	·HOOK	1		
30	09443-06038	·SPRING	1		

FIG. 27

E - 8

FIG. 27 DRIVESHAFT HOUSING

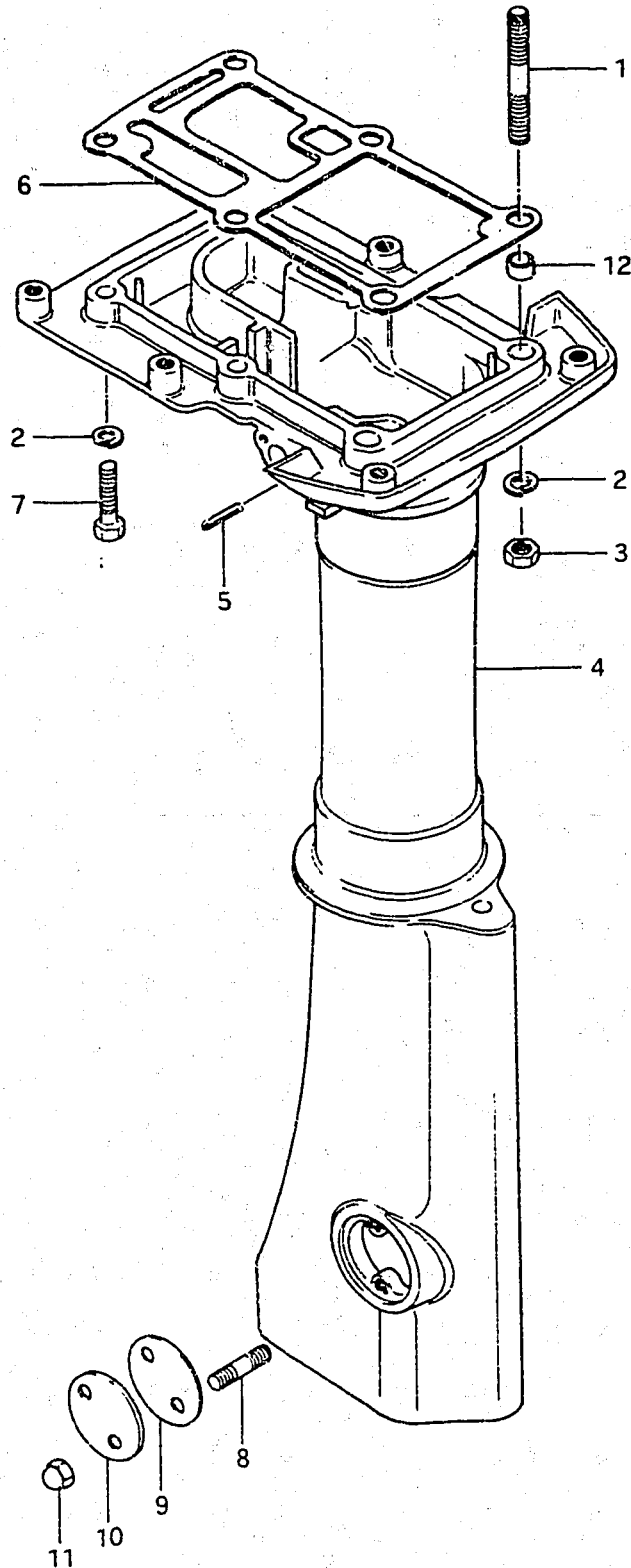

Ref. No.	Part No.	Description	Q'ty	Remarks
			5/8	
1	09108-08036	STUD BOLT	2	
2	09162-08003	LOCK WASHER	6	
3	09140-08003	NUT, drive shaft housing	2	
4-1	52110-98511-01J	HOUSING, drive shaft	1	S type, model G/J to 52110-98512-01J
4-2	52110-98512-01J	HOUSING, drive shaft	1	S type model VZ
4-3	52110-98521-01J	HOUSING, drive shaft	1	L type, model G to 52110-98522-01J
4-4	52110-98522-01J	HOUSING, drive shaft	1	DT5 L type, DT8G(L type), DT8J(L type)
4-5	52110-98523-01J	HOUSING, drive shaft	1	DT8VZ(L type)
5	09205-05001	DOWEL PIN, clutch lever	1	
6	52113-98500	GASKET, drive shaft housing	1	
7	09100-08112	BOLT	4	
8	09108-05002	STUD BOLT, clutch adjusting hole	2	
9	52116-98500	GASKET, clutch adjusting hole	1	
10	52115-98500-01J	COVER, clutch adjusting hole	1	
11	09145-05001	NUT, clutch adjusting hole	2	
12	09206-11006	SPACER, drive shaft housing	2	for 52110-98512-01J 52110-98523-01J model VZ

FIG. 28

E - 9

FIG. 28 GEAR CASE

Q'ty

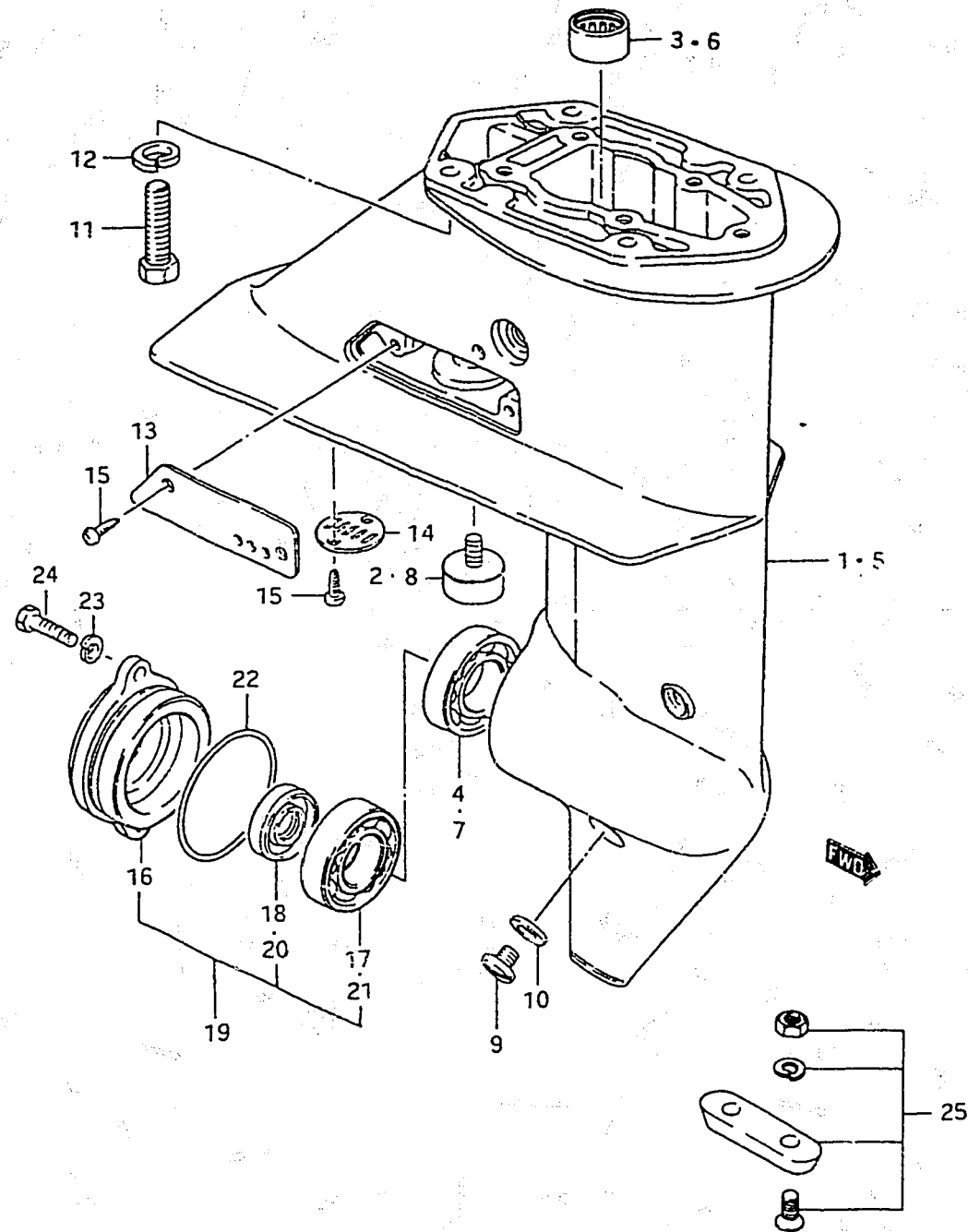

Ref. No.	Part No.	Description	5	8	Remarks
1-1	55100-98821-01J	CASE ASSY, gear	1	1	to 55100-98822-01J
1-2	55100-98822-01J	CASE ASSY, gear to (55110-98502-01J)+(55321-93141)	1	1	
2	55321-93141	·ZINC, protection	1	1	model G
3	09263-14010	·BEARING, pinion	1	1	
4	08113-60040	·BEARING, gear	1	1	model J/VZ
5	55110-98502-01J	CASE, gear	1	1	
6	09263-14010	·BEARING, pinion	1	1	model J/VZ
7	08113-60040	·BEARING, gear	1	1	
8	55321-93141	ZINC, protection	1	1	model G
9-1	09248-10003	PLUG, drain	3	3	
9-2	09248-10004	PLUG, drain	3	3	model J/VZ from 09248-10003
10-1	09168-10004	GASKET, drain plug	3	3	model G to 09168-10022
10-2	09168-10022	GASKET, drain plug	3	3	model J/VZ
11	09100-08112	BOLT, gear case	4	4	model G/J
12	09162-08003	LOCK WASHER, gear case	4	4	
13	55112-98500-01J	COVER, gear case side	1	1	model VZ from 55114-98500
14-1	55114-98500	COVER, gear case lower	1	1	
14-2	55114-98502	COVER, gear case lower	1	1	model J
15	03112-04109	SCREW, gear case	4	4	
16	56111-98501-01J	HOUSING, reverse gear bearing	1	1	to 56110-98501-01J
17	08113-60040	BEARING, gear	1	1	model G
18	09289-14002	OIL SEAL, bearing housing	1	1	
19-1	56110-98501-01J	HOUSING, reverse gear bearing	1	1	to 56110-98502-01J model J
19-2	56110-98502-01J	HOUSING, reverse gear bearing	1	1	model VZ
20	09289-14002	·OIL SEAL	1	1	model J/VZ
21	08113-60040	·BEARING, reverse gear	1	1	
22	09280-48003	O RING, bearing housing	1	1	OPT
23	09162-06001	LOCK WASHER	2	2	
24	09100-06020	BOLT, bearing housing	2	2	OPT
25	55300-95500	ZINC ASSY	1	1	

FIG. 29

E - 11

FIG. 29 PROPELLER

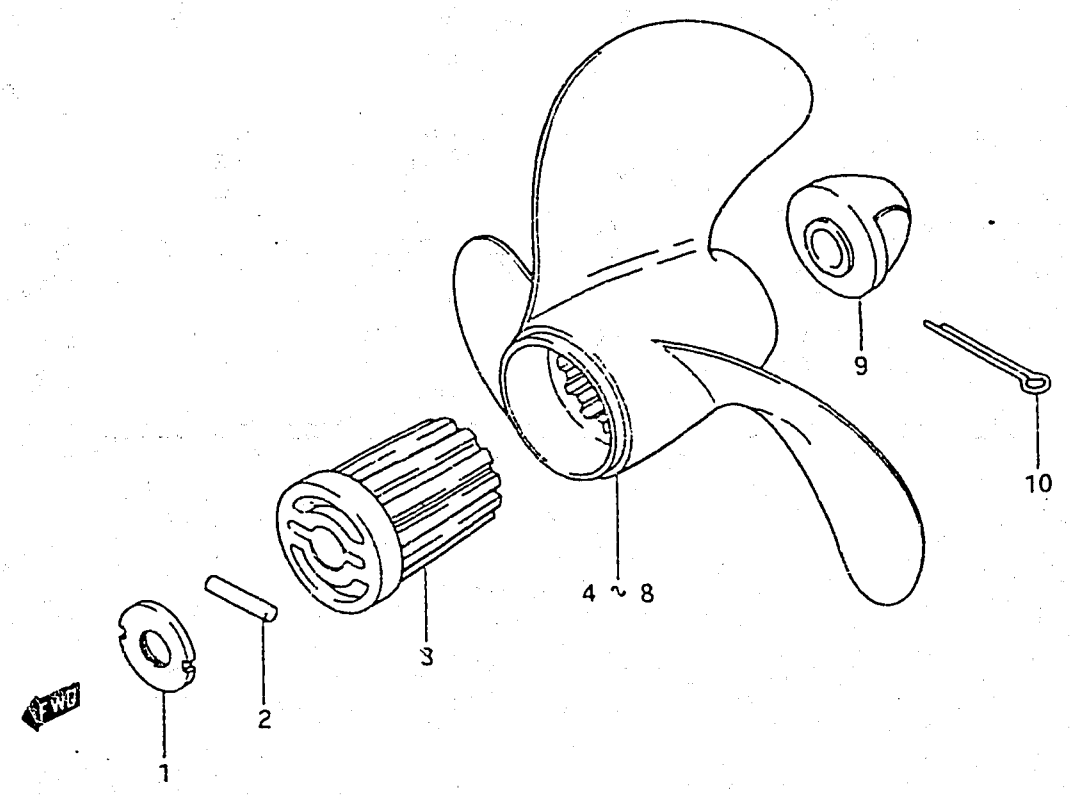

Ref. No.	Part No.	Description	Q'ty		Remarks
			5	8	
1	56115-98100	BUSHING, bearing housing	1	1	model G, J
2-1	09202-05013	SHEAR PIN	1	1	model G, to 09202-05020
2-2	09202-05020	SHEAR PIN	1	1	model J/VZ
3	58120-98511	BUSH, propeller	1	1	
4-1	58111-98721-01T	PROPELLER	1	-	3x200x130, F500
4-2	58111-98722-01T	PROPELLER	1	-	from 58111-98721-01T
5-1	58111-99721-01T	PROPELLER	1	-	3x200x150, F600
5-2	58111-99722-01T	PROPELLER	1	-	from 58111-99721-01T
6	58111-98502-01T	PROPELLER	1	1	3x200x170, F610 from 58111-98501-01T
7-1	58111-96001-01T	PROPELLER	-	1	3x215x180, F700
7-2	58111-96002-01T	PROPELLER	-	1	from 58111-96001-01T
8	58111-98101-01T	PROPELLER	-	1	3x200x190, F710 from 58111-98100-01T
9-1	58130-98100	NUT, propeller (model G, J)	1	1	from 58131-98500 to 58130-98101
9-2	58130-98101	NUT, propeller (model VZ)	1	1	
10	09204-03001	COTTER PIN	1	1	

FIG. 30

E - 12

FIG. 30 TRANSMISSION

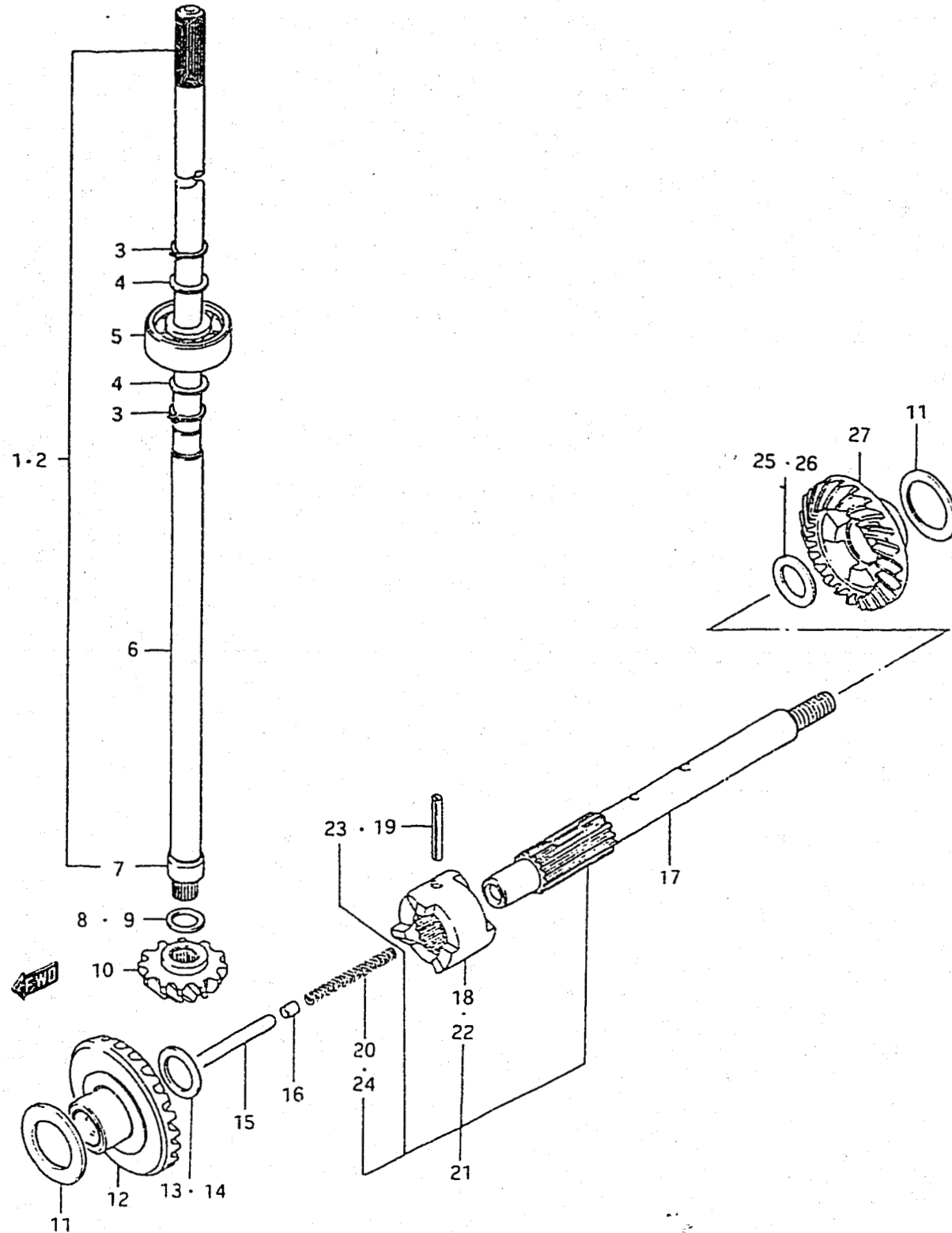

Ref. No.	Part No.	Description	Q'ty	Remarks
1-1	57110-98512	SHAFT, drive (S type)	1	model G, to 57110-98513
1-2	57110-98513	SHAFT, drive (S type)	1	
2-1	57110-98522	SHAFT, drive (L type)	1	model G, to 57110-98523
2-2	57110-98523	SHAFT, drive (L type)	1	
3	08331-31109	·CIRCLIP	2	
4	08211-10161	·THRUST WASHER	2	
5-1	09262-10002	·BEARING (model G)	1	to 09262-10003
5-2	09262-10003	·BEARING (S,L type)	1	
6	57116-98500	·SPACER (S,L type)	1	L:156
7	57117-98501	·INNER RACE, pinion bearing	1	
8	08211-10141	THRUST WASHER, pinion bearing	0~1	T:1.0
9-1	08221-10143	SHIM, pinion adjusting	0~2	T:0.1
9-2	08221-10144	SHIM, pinion adjusting	0~2	T:0.2
9-3	08221-10145	SHIM, pinion adjusting	0~1	T:0.5
10	57311-98500	PINION	1	
11-1	08221-20303	SHIM, gear back	0~2	T:0.1
11-2	08221-20304	SHIM, gear back	0~4	T:0.2
11-3	08221-20305	SHIM, gear back	0~2	T:0.5
12	57510-98500	GEAR, foward	1	
13	09160-12041	THRUST WASHER, forward gear	0~1	T:1.0
14	09181-12007	SHIM, forward gear	0~1	T:0.5
15	57631-98500	ROD, push	1	
16	57632-98500	PIN, push	1	

FIG. 30

E - 13

FIG. 30 TRANSMISSION

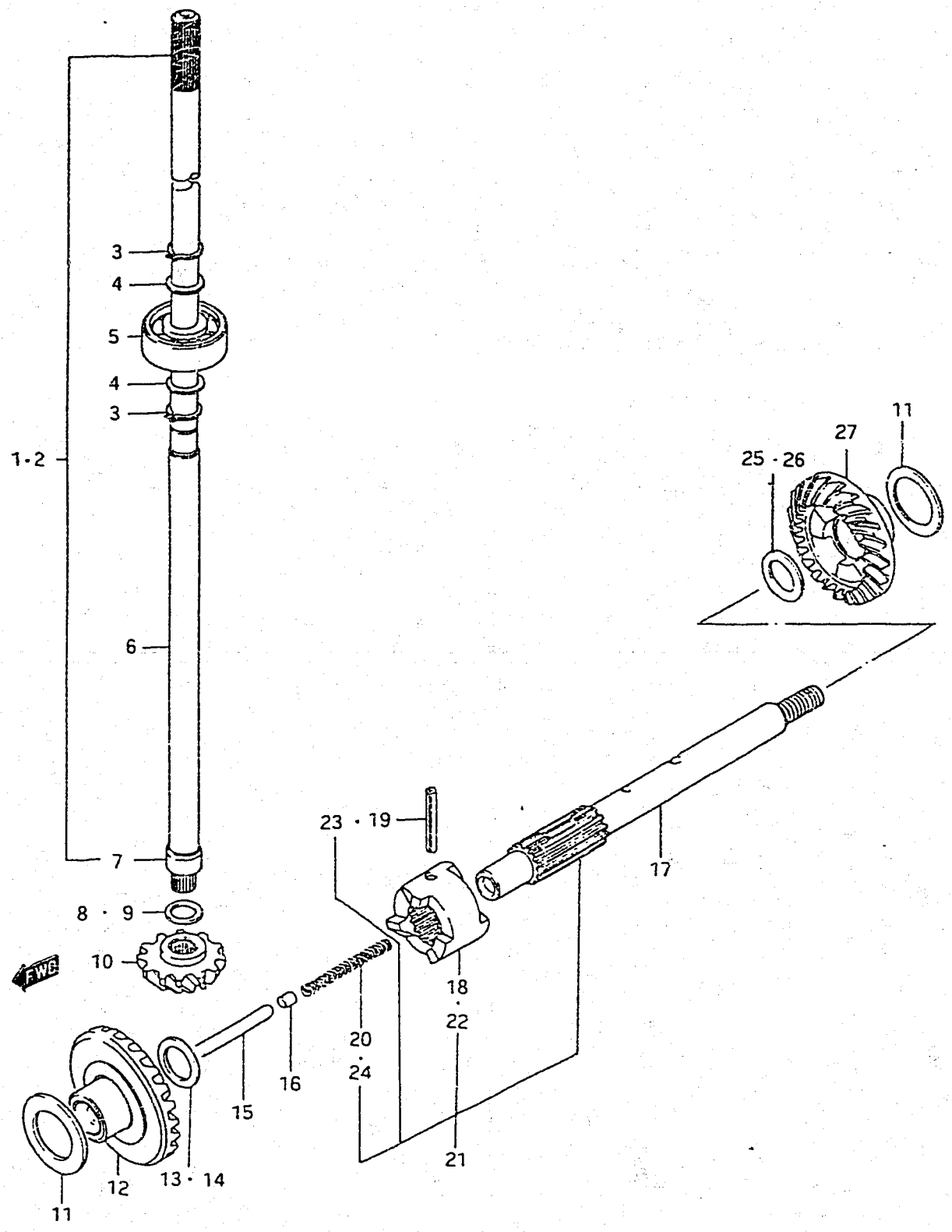

Ref. No.	Part No.	Description	Q'ty	Remarks
17	57611-98501	SHAFT, propeller	1	to 57600-98501 model G
18	57621-98500	SHIFTER, clutch dog	1	
19	09209-04017	PIN, clutch dog shifter	1	
20	09440-05019	SPRING, return	1	model J/VZ
21	57600-98501	SHAFT, propeller	1	
22	57621-98501	SHIFTER, clutch dog from 57621-98500	1	
23	09209-04017	PIN, shifter	1	T:1.5
24	09440-05019	SPRING, return	1	
25	09160-14022	THRUST WASHER, reverse gear	0~1	T:0.5
26	09181-14001	SHIM, reverse gear	0~1	
27	57520-98510	GEAR, reverse	1	

FIG.31

F - 2

FIG.31 LOWER COVER

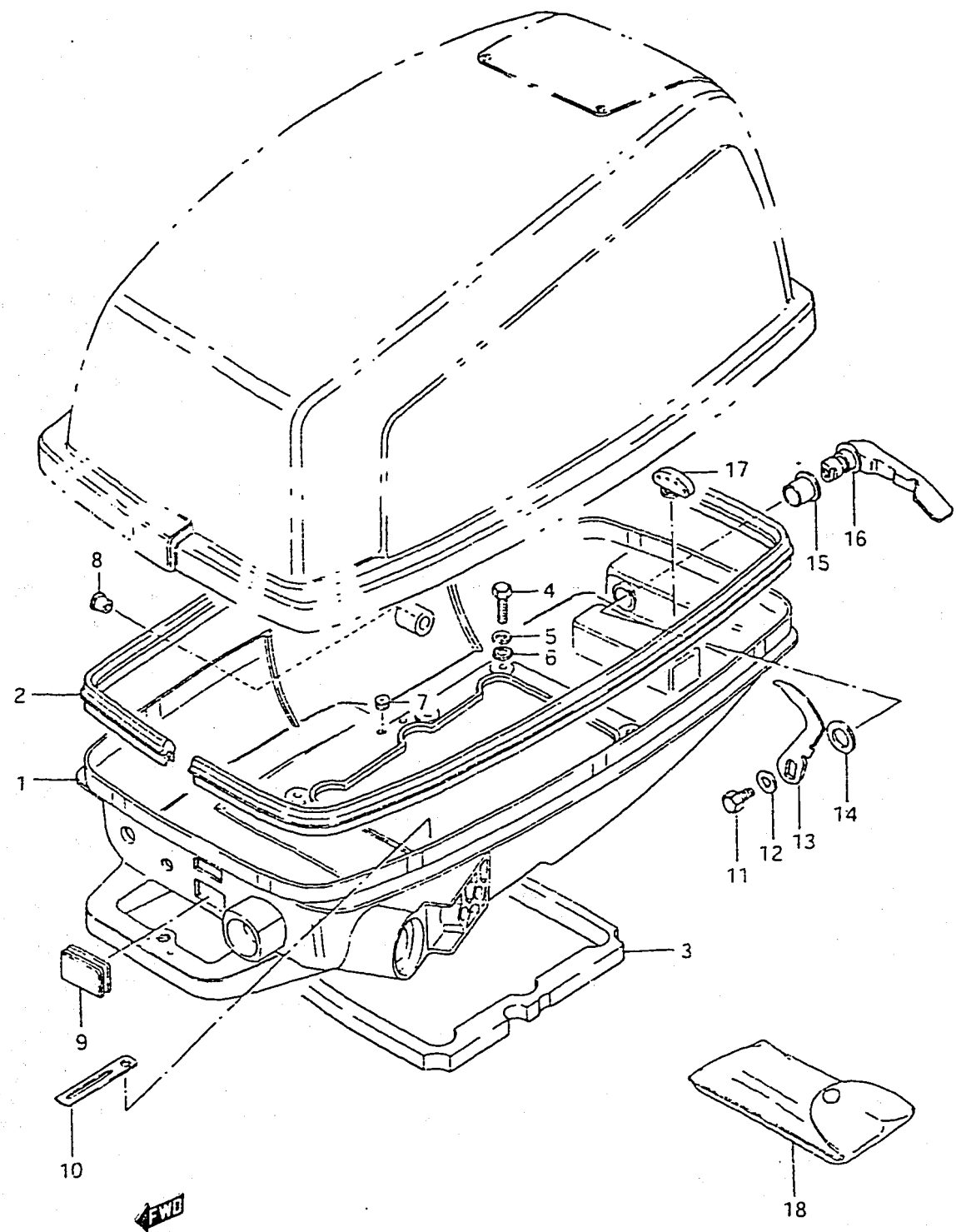

Ref. No.	Part No.	Description	Q'ty		Remarks
			5	8	
1-1	61111-98100-01J	COVER, engine lower	1	1	model G to 61111-98101-01J
1-2	61111-98101-01J	COVER, engine lower	1	1	L:30
1-3	61111-98102-01J	COVER, engine lower	1	1	L:79
2-1	61112-98100	RUBBER, engine lower	1	1	model G
2-2	61112-98101	RUBBER, engine lower	1	1	model J/VZ from 61112-98100
3	61113-98500	SEAL, engine lower	1	1	
4	09100-06020	BOLT, engine lower	6	6	
5	09162-06001	LOCK WASHER	6	6	model G
6	09160-06015	WASHER	6	6	model J/VZ
7	09250-08008	PLUG, inter lock hole	1	1	
8	09250-10001	PLUG, remocon shaft hole	1	1	
9-1	39669-93500	CAP, socket (model G)	1	1	from 39669-93300 to 39669-93501
9-2	39669-93501	CAP, socket	1	1	model J
9-3	39669-93502	CAP, socket	1	1	model VZ
10	09404-06401	CLAMP, stop switch	1	1	
11-1	01107-06108	BOLT	1	1	model G/J
11-2	01907-06108	BOLT (to 01107-06108)	1	1	model VZ
12	08322-21068	WASHER	1	1	
13	61631-98100	HOOK, lower cover	1	1	
14-1	09164-13001	WASHER, wave	1	1	model G
14-2	09164-13005	WASHER, wave	1	1	model J/VZ (SUS)

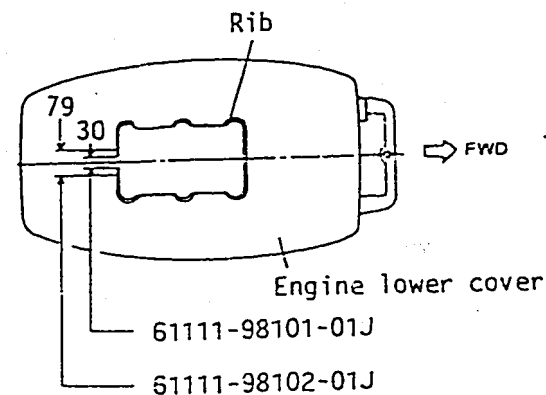
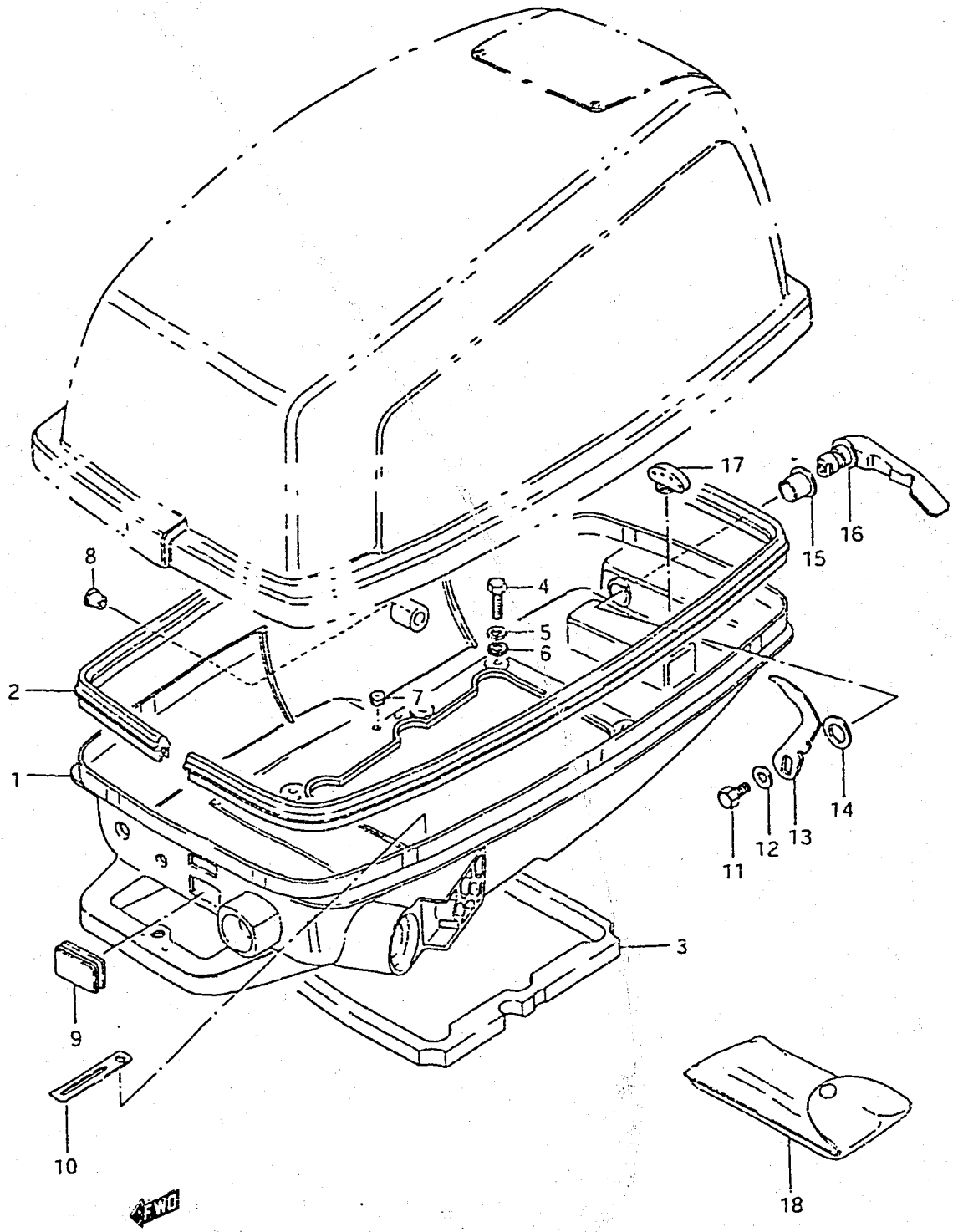

FIG.31

F - 3

FIG.31 LOWER COVER



Ref. No.	Part No.	Description	Q'ty		Remarks
			5	8	
15	09306-13002	BUSHING, hook lever	1	1	
16	61633-96002-01J	LEVER, hook	1	1	
17-1	61521-98400	HOLDER, shear pin	1	-	DT5G
17-2	61521-96000	HOLDER, shear pin	1	1	
18-1	09800-00128	TOOL SET	1	1	to 09800-00805,model G
18-2	09800-00805	TOOL SET	1	1	model J,to 09800-81800
18-3	09800-81800	TOOL SET	1	1	model VZ

FIG.32

F - 4

FIG.32 ENGINE COVER 1

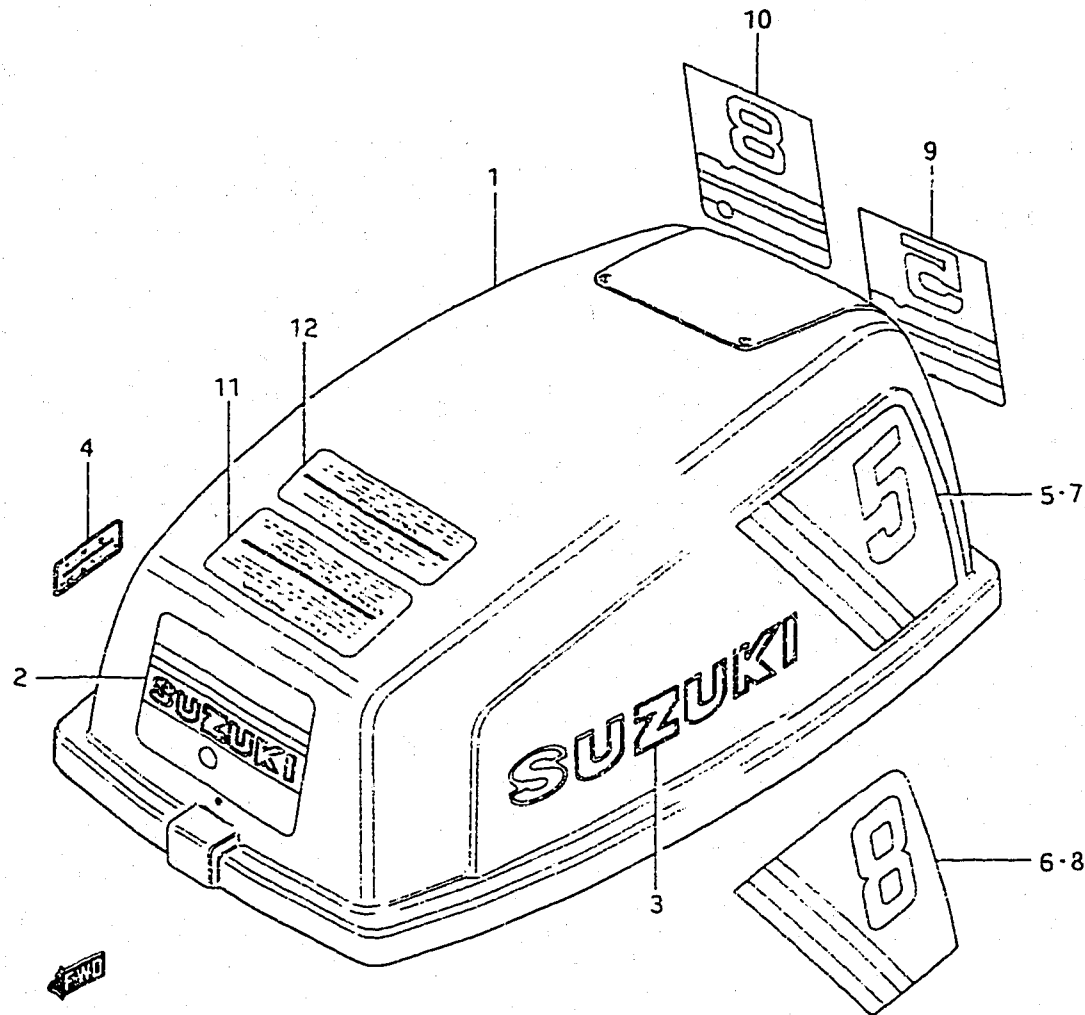

Ref. No.	Part No.	Description	Q'ty		Remarks
			5	8	
1-1	61400-98880-01T	COVER SET, engine-	1	-	to 61400-98881-01T
1-2	61400-98881-01T	COVER SET, engine-(model G)	1	-	to 61400-98882-01T
1-3	61400-98883-01T	COVER SET, engine-	1	1	from 61400-98882-01T to 61400-98884-01T
1-4	61400-98884-01T	COVER SET, engine-(model J)	1	1	to 61400-98885-01T
1-5	61400-98885-01T	COVER SET, engine-	1	1	
1-6	61400-98886-01T	COVER SET, engine (model VZ)	1	1	
2-1	61422-98100	·EMBLEM, front "SUZUKI"	1	-	to 61422-98101, model G
2-2	61422-98101	·EMBLEM, front "SUZUKI"	1	1	
3-1	61441-98500	·EMBLEM, cover side "SUZUKI"	2	2	model G
3-2	61441-98511	·EMBLEM, cover side "SUZUKI"	2	2	model J/VZ
4-1	21131-96001	·MARK, clutch shifting	1	1	to 21131-96002
4-2	21131-96002	·MARK, clutch shifting	1	1	
5	61443-98510	DICURL, cover side RH "5"	1	-	
6	61443-98100	DICURL, cover side RH "8"	-	1	
7	61453-98510	DICURL, cover side LH "5"	1	-	
8	61453-98100	DICURL, cover side LH "8"	-	1	
9-1	61435-98510	EMBLEM, rear "5" (model G)	1	-	to 61435-98511
9-2	61435-98511	EMBLEM, rear "5"	1	-	for 61400-98882-01T for 61400-98884-01T
10-1	61435-98100	EMBLEM, rear "8" (model G)	1	-	to 61435-98101
10-2	61435-98101	EMBLEM, rear "8"	-	1	for 61400-98882-01T for 61400-98884-01T
11	61458-95201	MARK, safety warning	1	1	
12-1	61457-93001	MARK, warning	1	1	model G/J
12-2	61457-93002	MARK, warning	1	1	model VZ

FIG.33 (F-6) : VZ (E13, E40)
 FIG.34 (F-7) : DT5W (J/VZ)

FIG. 33

F - 6

FIG.33 ENGINE COVER 2 model VZ (E13, E40)
Q'ty

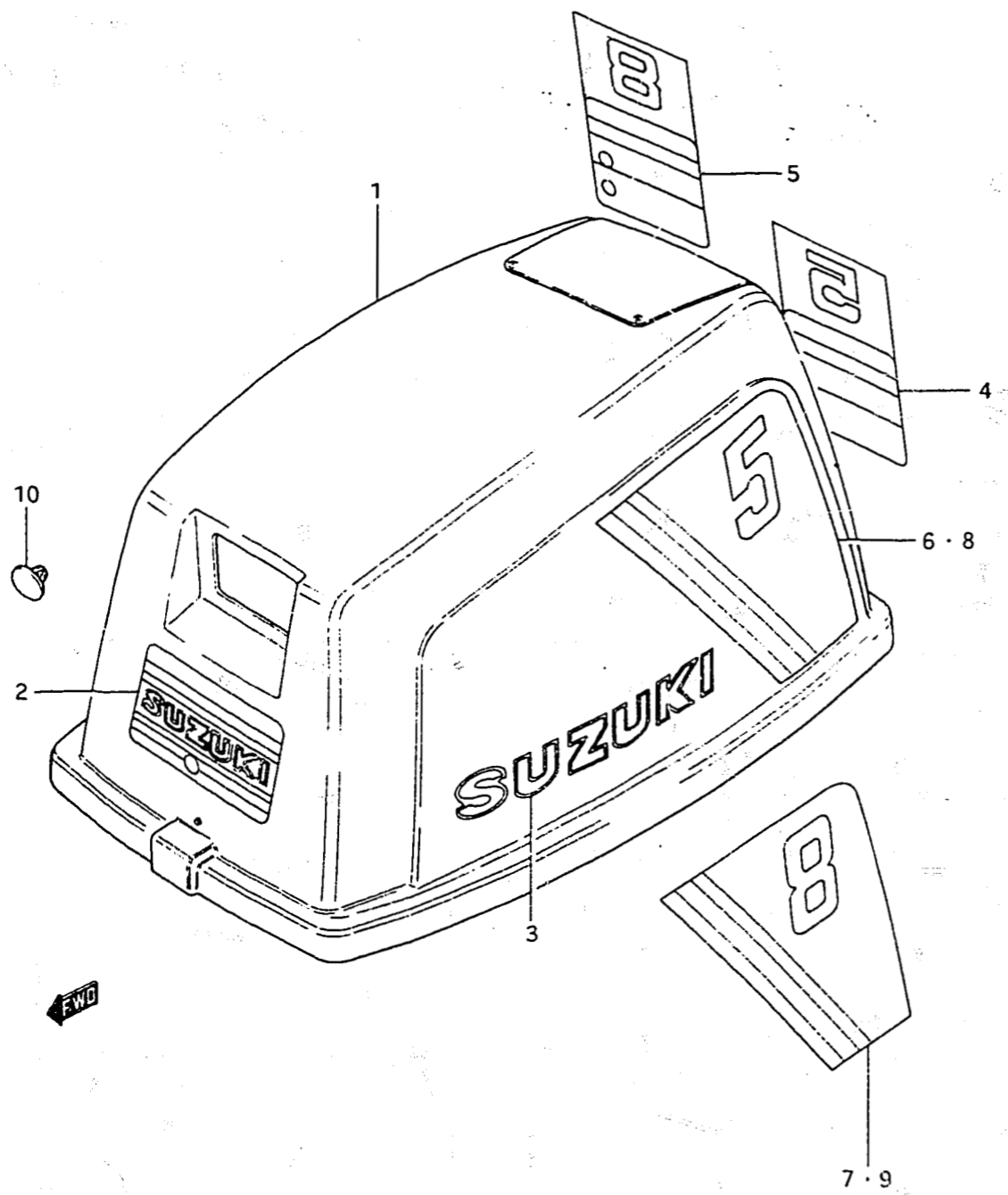

Ref. No.	Part No.	Description	5	8	Remarks
1	61401-98630-01T	COVER SET, engine	1	1	
2	61422-98511	•EMBLEM, front	1	1	
3	61441-98511	•EMBLEM, cover side "SUZUKI"	1	1	
4	61435-98530	EMBLEM, rear "5"	1	-	
5	61435-98110	EMBLEM, rear "8"	-	1	
6	61443-98520	DICURL, cover side RH "5"	1	-	
7	61443-98110	DICURL, cover side RH "8"	-	1	
8	61453-98520	DICURL, cover side LH "5"	1	-	
9	61453-98110	DICURL, cover side LH "8"	-	1	
10	09250-08005	CAP, starter rope hole	1	1	

FIG.32 (F-4) : DT5 (G/J/VZ)/DT8 (G/J/VZ) E1
FIG.34 (F-7) :DT5W (J/VZ)

FIG. 35

F - 8

FIG. 35 HANDLE

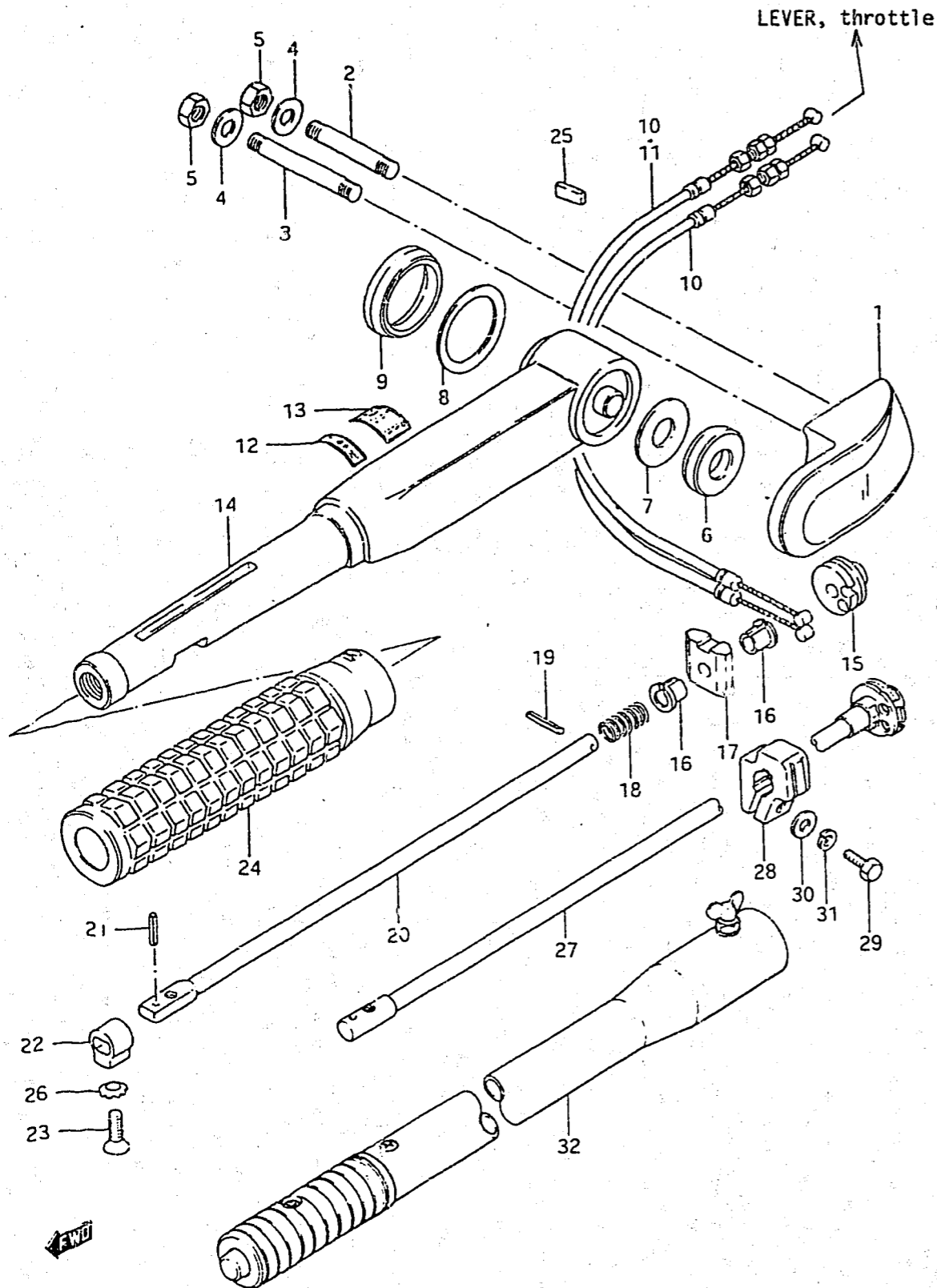

Ref. No.	Part No.	Description	Q'ty	Remarks
1	63113-98100-01J	COVER, tiller handle	1	
2	01421-08508	STUD BOLT	1	
3	01421-08608	STUD BOLT	1	
4	08322-11088	WASHER	2	
5	08310-12088	NUT	2	
6	63115-98100	BUSHING, tiller handle cover	1	
7	09160-13008	WASHER (13.5x31.5x0.5)	1	
8	09160-32004	WASHER (32.5x42x0.5)	1	
9	63116-98100	BUSHING, tiller handle	1	
10-1	63610-98100	CABLE ASSY, throttle	2	DT5G
10-2	63610-98100	CABLE ASSY, throttle (1)	1	L:240, for Ref.No.11
11	63610-98110	CABLE ASSY, throttle (2)	1	L:210, for Ref.No.10-2
12	63215-93101	MARK, handle grip	1	model G
13	63215-93400	MARK, handle grip	1	
14-1	63111-93202-01J	HANDLE, tiller (model G)	1	to 63111-93203-01J
14-2	63111-93203-01J	HANDLE, tiller	1	to 63111-93204-01J
14-3	63111-93204-01J	HANDLE, tiller	1	
15	63222-93200	DRUM, handle rod	1	
16-1	63225-93200	BUSHING, handle rod	2	model G/J
16-2	63225-93200	BUSHING, handle rod	1	model VZ
17	63224-93202	PROTECTOR, stop switch wire	1	model G/J
18	63226-93200	SPRING, handle rod	1	
19	09205-03004	PIN	1	model G/J
20	63221-93200	ROD, handle	1	model G/J
21	63227-93200	PIN	1	
22	63223-93200	STOPPER, handle rod	1	
23	09126-06004	SCREW	1	
24	63210-93200	GRIP, handle	1	
25	63117-93400	PROTECTOR, stop switch wire	1	
26	09163-06001	LOCK WASHER	1	

FIG. 35

F - 9

45

FIG. 35 HANDLE

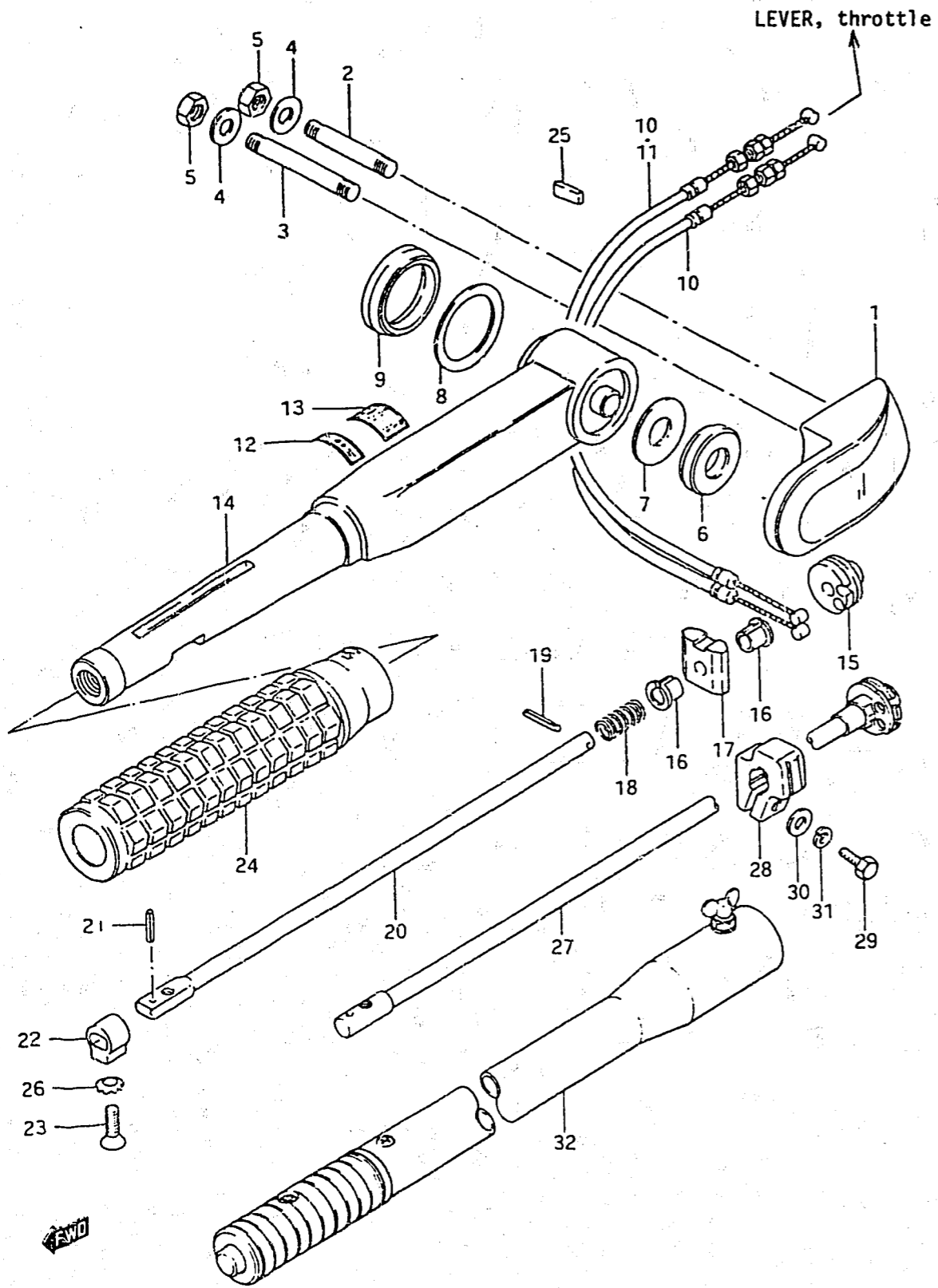

Ref. No.	Part No.	Description	Q'ty	Remarks
			5/8	
27	63220-98500	ROD, handle	1	} model VZ
28	63241-94300	ADJUSTER, grip	1	
29	09100-06019	BOLT (6x16)	1	
30	09160-06015	WASHER (6,5x13x1)	1	
31	09162-06001	LOCK WASHER	1	
32	63300-94300	BAR ASSY, extention	1	OPT

FIG. 36

F - 10

FIG. 36 FUEL TANK 1

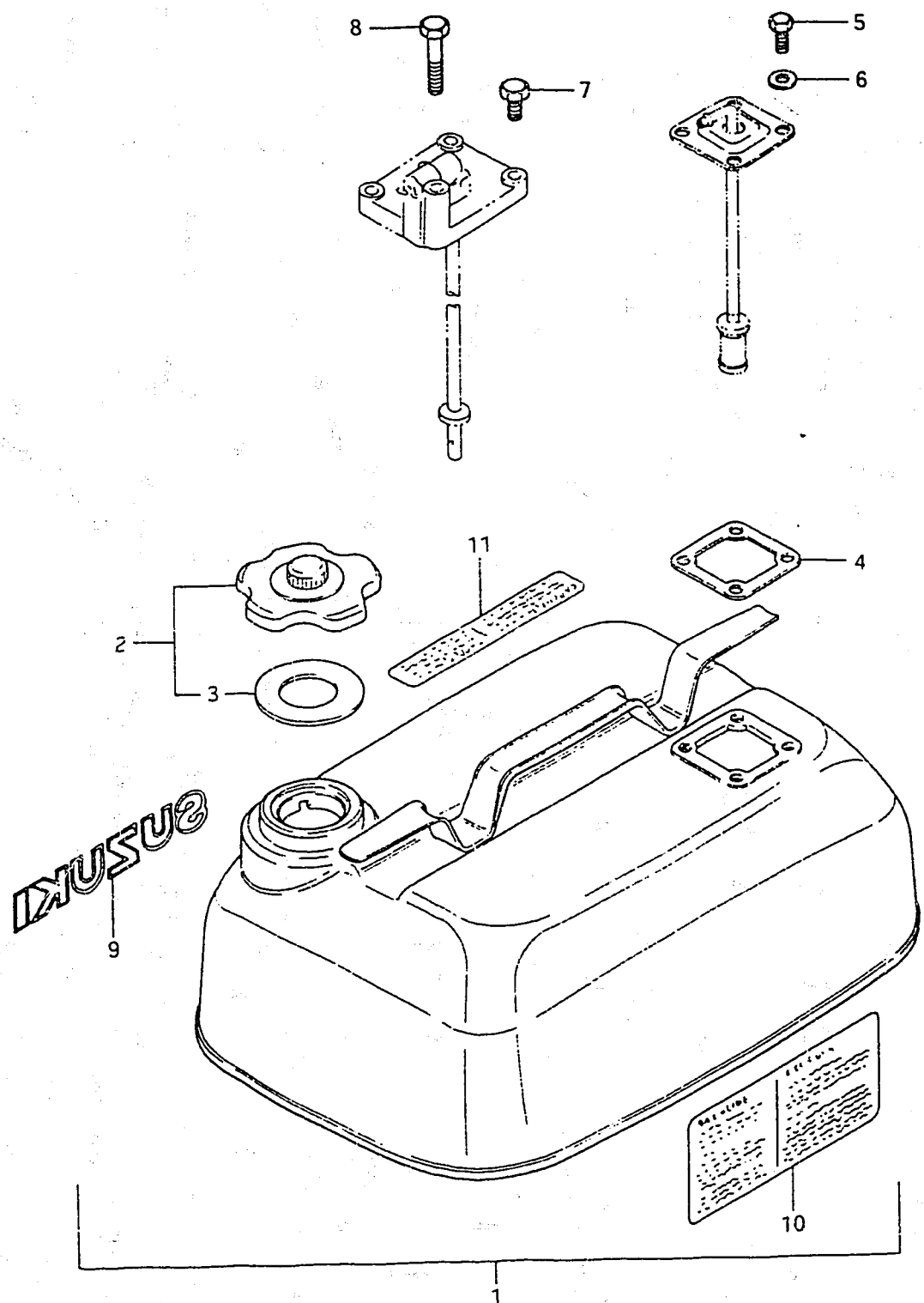

Ref. No.	Part No.	Description	Q'ty	Remarks
			5/8	
1-1	65800-98843	TANK, separate fuel (15ℓ)(4 U.S GAL)(3.3 IMP. GAL)	1	Incl Ref.No.2~6 to 65800-98844 model G
1-2	65800-98844	TANK, separate fuel (15ℓ)(4 U.S GAL)(3.3 IMP. GAL)	1	Incl Ref.No.2~6 model G
1-3	65800-98845	TANK, separate fuel (15ℓ)(4 U.S GAL)(3.3 IMP. GAL) from 65800-98844, to 65800-98846	1	Incl Ref. No.2~6 model J
1-4	65800-98846	TANK, separate fuel (15ℓ)(4 U.S GAL)(3.3 IMP. GAL)	1	Incl Ref.No.2~6 model VZ
2-1	65510-98502	·CAP ASSY, fuel tank	1	model G to 65510-98503
2-2	65510-98503	·CAP ASSY, fuel tank	1	model G
2-3	65510-98504	·CAP ASSY, fuel tank from 65510-98503, to 65510-98505	1	model J
2-4	65510-98505	·CAP ASSY, fuel tank	1	model VZ
3-1	65561-98501	··GASKET, tank cap	1	model G to 65561-98502
3-2	65561-98502	··GASKET, tank cap	1	
4	65871-93001	·GASKET, fuel gauge	1	
5-1	01107-06108	·BOLT	4	model G/J
5-2	01907-06108	·BOLT (to 01107-06108)	4	model VZ
6	08322-21068	·WASHER	4	
7	01107-06168	BOLT	3	DT5G(E9, E13) DT5J(E9, E13)
8	01107-06408	BOLT	1	
9	61441-98500	MARK, ornament	1	
10	65316-93303	MARK, fuel caution	1	
11	65317-98500	MARK, fuel capacity	1	

FIG. 37 (F-11) : DT8 (E9, E13, E40)
 FIG. 38 (F-12) : E28

FIG. 37

F - 11

47

FIG. 37 FUEL TANK 2 : DT8 (E9, E13, E40)

Q'ty

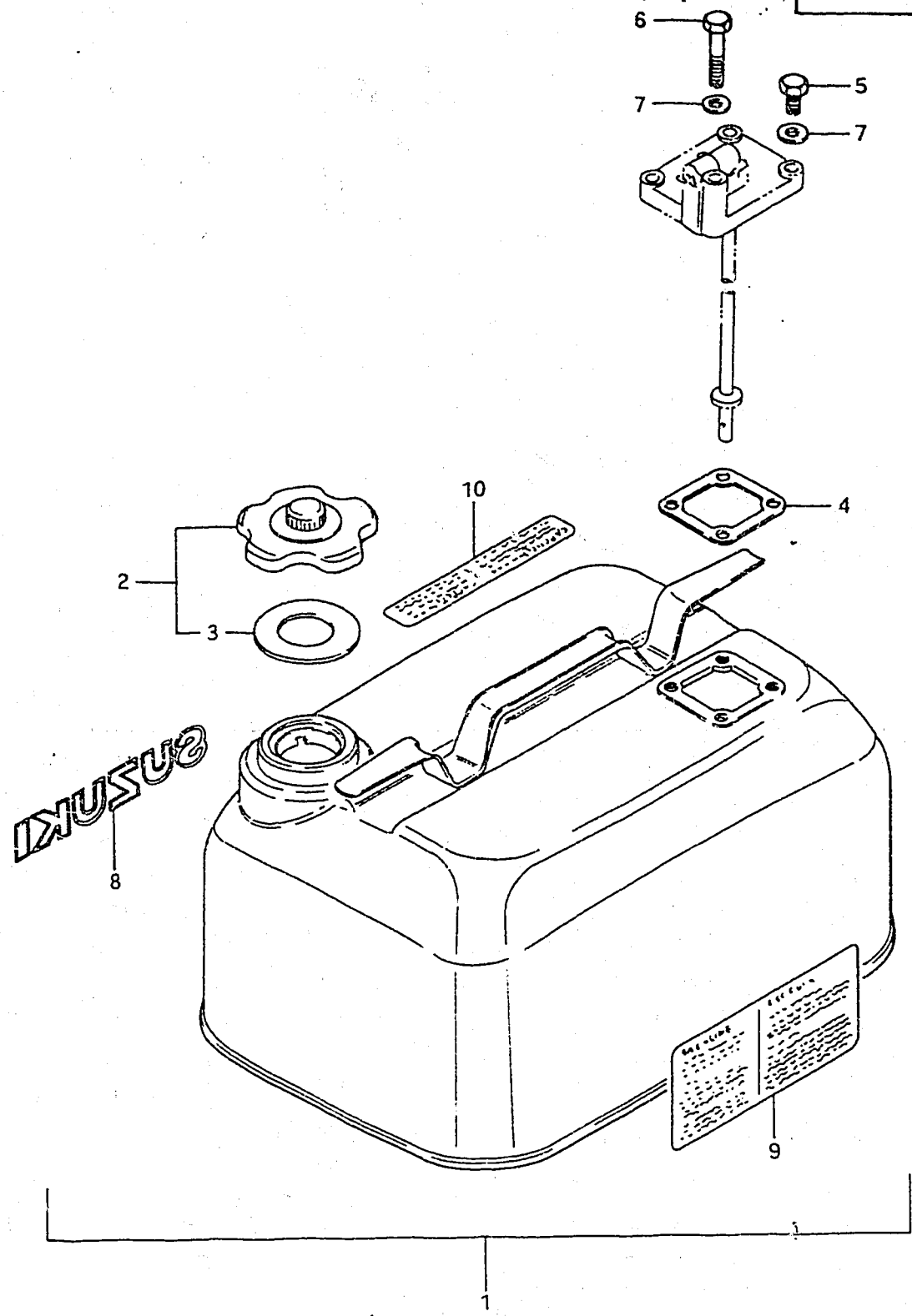

Ref. No.	Part No.	Description	8	Remarks
1-1	65800-95813	TANK SET, fuel (23ℓ)(6 U.S GAL)(5 IMP. GAL)	1	to 65800-95814 model G
1-2	65800-95814	TANK SET, fuel (23ℓ)(6 U.S GAL)(5 IMP. GAL)	1	
1-3	65800-95815	TANK SET, fuel (23ℓ)(6 U.S GAL)(5 IMP. GAL)	1	model J from 65800-95814 to 65800-95816
1-4	65800-95816	TANK SET, fuel (23ℓ)(6 U.S GAL)(5 IMP. GAL)	1	model VZ
2-1	65510-98502	•CAP ASSY, tank	1	to 65510-98503 model G
2-2	65510-98503	•CAP ASSY, tank	1	
2-3	65510-98504	•CAP ASSY, tank	1	model J from 65510-98503
2-4	65510-98505	•CAP ASSY, tank	1	model VZ
3-1	65561-98501	••GASKET, tank cap	1	to 65561-98502, model G
3-2	65561-98502	••GASKET, tank cap	1	
4	65871-93001	•GASKET, fuel gauge	1	
5	01107-06168	•BOLT	3	
6	01107-06408	•BOLT	1	
7	08322-21068	•WASHER	4	
8	61441-98500	MARK, ornament	1	
9	65316-93303	MARK, fuel caution	1	
10	65317-95200	MARK, fuel capacity	1	

FIG.38

F - 12

FIG.38 FUEL TANK 3 (E28)

Q'ty

Ref. No.	Part No.	Description	Q'ty	Remarks	
(E28)					
1-1	65800-98850	TANK SET, separate fuel (15ℓ)(4U.S GAL.)(3.3 IMP. GAL)	1	Incl. Ref.No.2~15 to 65800-98851 model G	
1-2	65800-98851	TANK SET, separate fuel (15ℓ)(4U.S GAL)(3.3 IMP.GAL)	1		
1-3	65800-98852	TANK SET, separate fuel. (15ℓ)(4U.S GAL)(3.3 IMP.GAL)	1		model J from 65800-98851 to 65800-98853
1-4	65800-98853	TANK SET, separate fuel (15ℓ)(4U.S GAL)(3.3 IMP.GAL)	1		model VZ
2-1	65510-98502	•CAP ASSY, fuel tank	1	to 65510-98503 model G	
2-2	65510-98503	•CAP ASSY, fuel tank	1		
2-3	65510-98504	•CAP ASSY, fuel tank	1	model J from 65510-98503	
2-4	65510-98505	•CAP ASSY, fuel tank	1	model VZ	
3-1	65561-98501	••GASKET, tank cap	1	to 65561-98502 model G	
3-2	65561-98502	••GASKET, tank cap	1	for 65800-98851 for 65800-98853	
4	65871-93001	•GASKET, fuel gauge	1		
5	65880-98500	•OUTLET ASSY, tank	1		
6	65830-93301	••FILTER	1		
7	08322-21058	••WASHER	1		
8	08321-21058	••LOCK WASHER	1		
9	02112-05088	••SCREW	1		
10	08322-21068	•WASHER	4		
11	01107-06108	•BOLT	4		
12	61441-98500	•MARK, ornament	1		
13	65317-98500	•MARK, fuel capacity	1		
14	65319-98500	•MARK, fuel tank model	1		
15	65316-93303	•MARK, fuel caution	1		

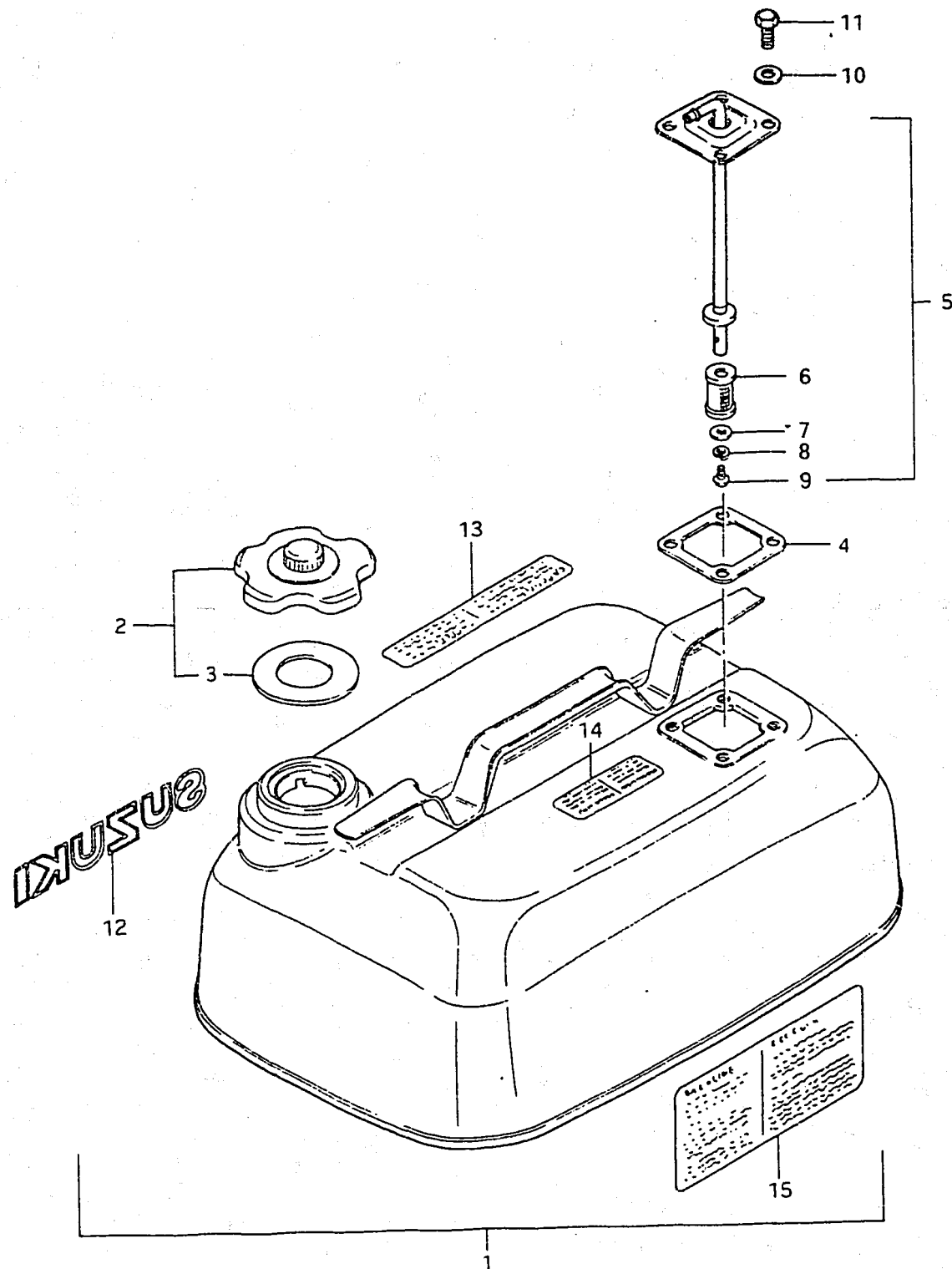
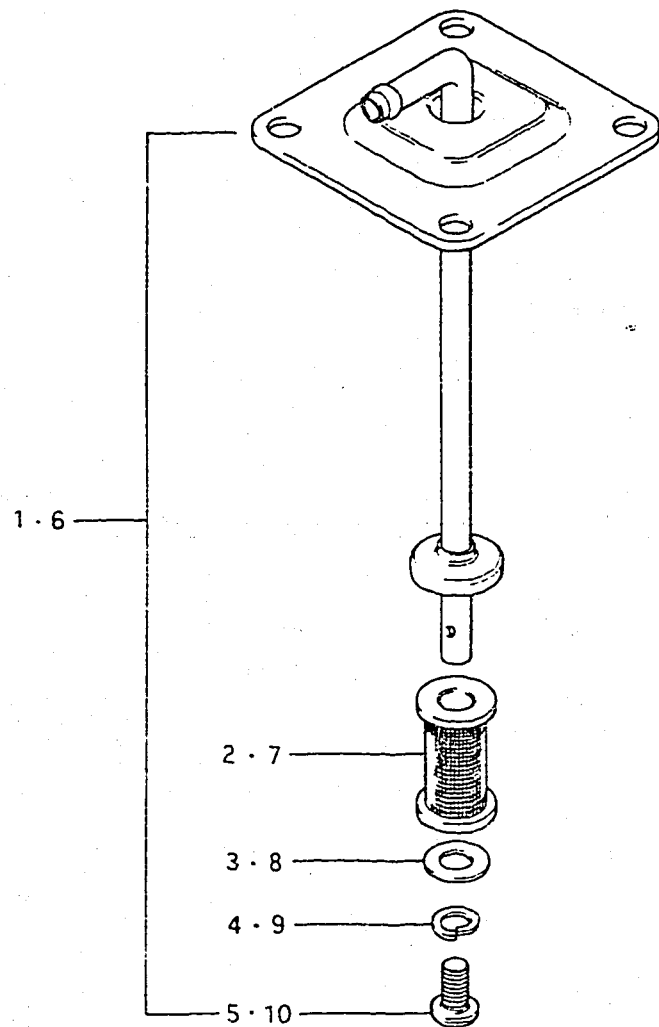

FIG. 39

G - 2

49

FIG. 39 FUEL TANK OUTLET



Ref. No.	Part No.	Description	Q'ty		Remarks
			5	8	
1	65880-98500	OUTLET ASSY, tank	1	1	
2	65830-93301	·FILTER	1	1	
3	08322-21058	·WASHER	1	1	
4	08321-21058	·LOCK WASHER	1	1	
5	02112-05088	·SCREW	1	1	
6	65880-95200	OUTLET ASSY, tank	-	1	} DT8VZ(E13, E40)
7	65830-93301	·FILTER	-	1	
8	08322-21058	·WASHER	-	1	
9	08321-21058	·LOCK WASHER	-	1	
10	02112-05088	·SCREW	-	1	

FIG.41

G - 5

FIG.41 FUEL GAUGE : DT8G (E9, E13), DT8J (E9, E13)
Q'ty

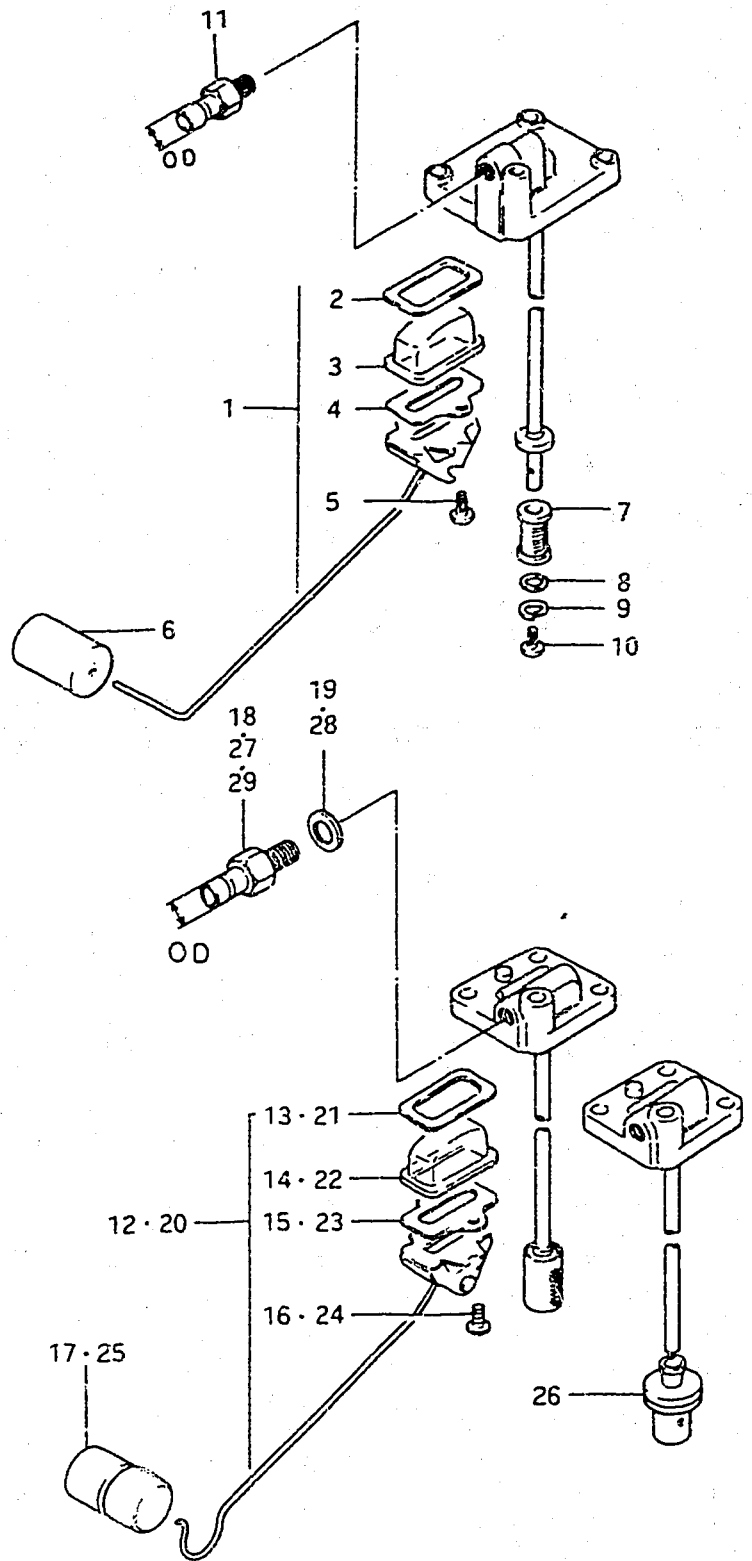

Ref. No.	Part No.	Description	Q'ty	Remarks
1	65850-95212	GAUGE ASSY, fuel	1	~0801-004236
2	65854-93001	·GASKET, strainer	1	
3	65853-93001	·STRAINER	1	
4	65862-93000	·GASKET, arm holder	1	
5	02112-04108	·SCREW	2	
6	65864-93000	·FLOAT	1	model G
7	65830-93301	·FILTER	1	
8	08322-21058	·WASHER	1	
9	08321-21058	·LOCK WASHER	1	
10	02112-05088	·SCREW	1	
11	65720-98511	·PLUG, connector	1	M10,OD:11φ
12	65850-95501	GAUGE ASSY, fuel	1	0801-004237~
13	65854-93001	·GASKET, strainer	1	
14	65853-93001	·STRAINER	1	
15	65862-93000	·GASKET, arm holder	1	
16	02112-04108	·SCREW	2	model G
17	65864-93000	·FLOAT	1	
18	65740-95500	·PLUG, connector	1	M12,OD:13φ
19	09168-12001	·GASKET, plug	1	
20	65850-95503	GAUGE ASSY, fuel	1	from 65850-95501
21	65854-93001	·GASKET, strainer	1	
22	65853-93001	·STRAINER	1	
23	65862-93000	·GASKET, arm holder	1	
24	02112-04108	·SCREW	2	
25	65864-95200	·FLOAT	1	model J
26	65830-95500	·FILTER	1	
27	65740-95500	·PLUG, connector	1	M12,OD:13φ
28	09168-12001	·GASKET, plug	1	
29	65720-98590	PLUG, connector	1	OPT,M12,OD:11φ

FIG.40 (G-3) : DT5G (E9, E13), DT5J (E9, E13)

FIG. 42

G - 7

FIG. 42 FUEL HOSE

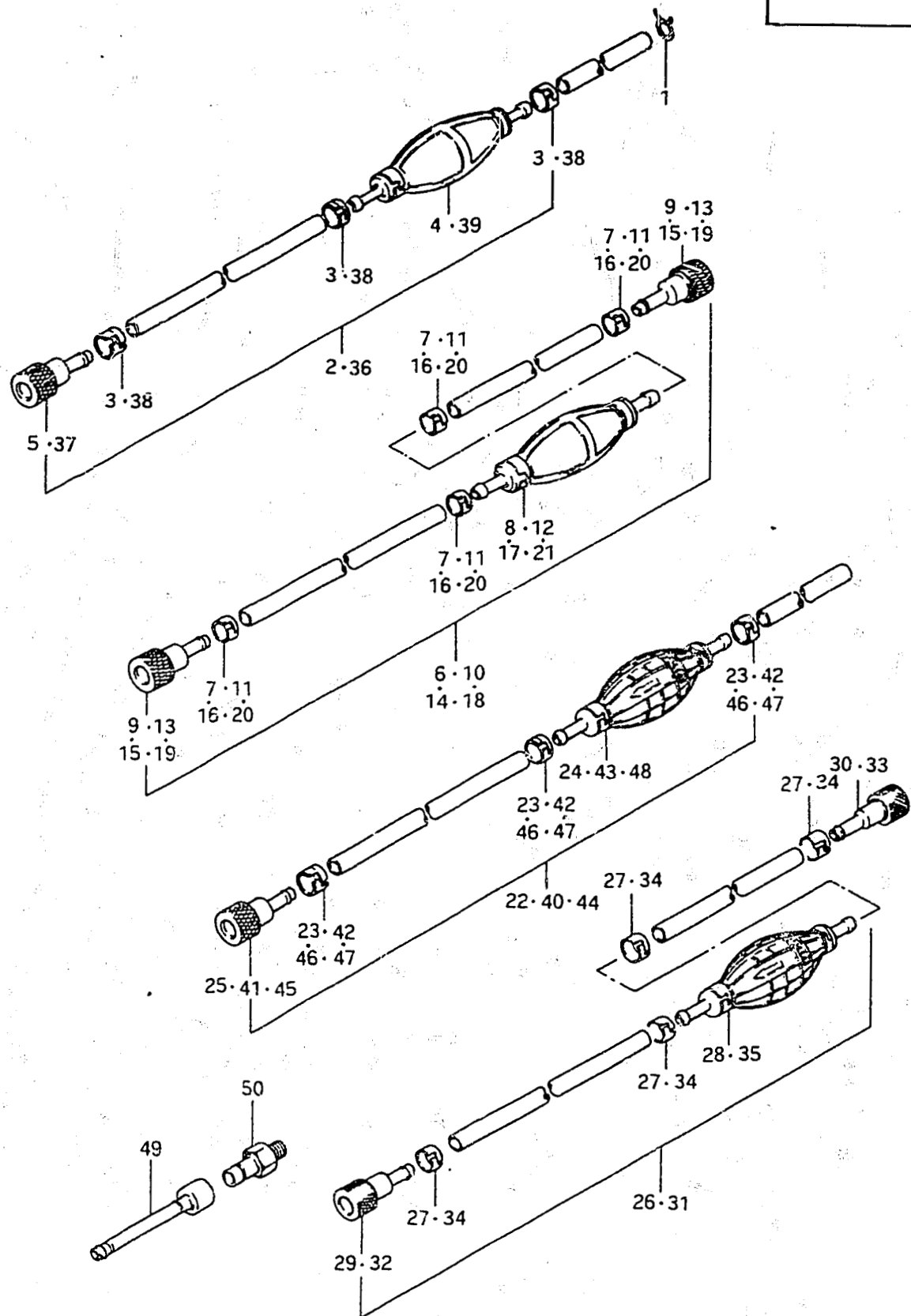

Ref. No.	Part No.	Description	Q'ty		Remarks
			5	8	
1	09401-11402	CLIP	1	1	} model G to 65770-99702
2-1	65700-98503	HOSE ASSY, fuel (L:2520)	1	1	
2-2	65700-98992	HOSE ASSY, fuel (L:2520)	1	1	
3	09401-13402	CLIP	3	3	
4	65770-99701	PUMP, squeeze	1	1	
5-1	65750-98502	SOCKET, fuel hose (ID:11φ)	1	1	
5-2	65750-98990	SOCKET, fuel hose (ID:11φ) from 65750-98502, to 65750-98505	1	1	
6	65700-98514	HOSE ASSY, fuel (L:1953)	1	-	
7	09401-13402	CLIP	4	-	
8	65770-99701	PUMP, squeeze	1	-	
9	65750-98502	SOCKET, fuel hose (ID:11φ)	2	-	
10	65700-95990	HOSE ASSY, fuel to 65700-95202	1	-	
11	09401-13402	CLIP	4	-	} DT5G(E9,E13) to 65770-99702 to 65750-98505 0501-005544~ L:2550→1953
12	65770-99701	PUMP, squeeze	1	-	
13	65750-98502	SOCKET, fuel hose (ID:11φ)	2	-	
14	65700-95202	HOSE ASSY, fuel (L:2550)	-	1	
15	65750-98502	SOCKET, fuel hose (ID:11φ)	-	2	
16	09401-13402	CLIP	-	4	
17	65770-99701	PUMP, squeeze to 65770-99702	-	1	
18	65700-95990	HOSE ASSY, fuel (L:2550)	-	1	
19	65750-98502	SOCKET, fuel hose (ID:11φ)	-	2	
20	09401-13402	CLIP	-	4	
21	65770-99701	PUMP, squeeze	-	1	
22	65700-98505	HOSE ASSY, fuel	1	1	} model J L:2550→1953 to 65700-95205
23	09401-13402	CLIP	3	3	
24	65770-99702	PUMP, squeeze	1	1	
25	65750-98505	SOCKET, fuel hose (ID:11φ)	1	1	
26	65700-95204	HOSE ASSY, fuel	1	-	
27	09401-13402	CLIP	4	-	
28	65770-99702	PUMP, squeeze	1	-	
29	65750-98505	SOCKET, fuel hose (ID:11φ)	1	-	
30	65750-93000	SOCKET, fuel hose (ID:13φ)	1	-	

FIG.42

G - 8

53

FIG.42 FUEL HOSE

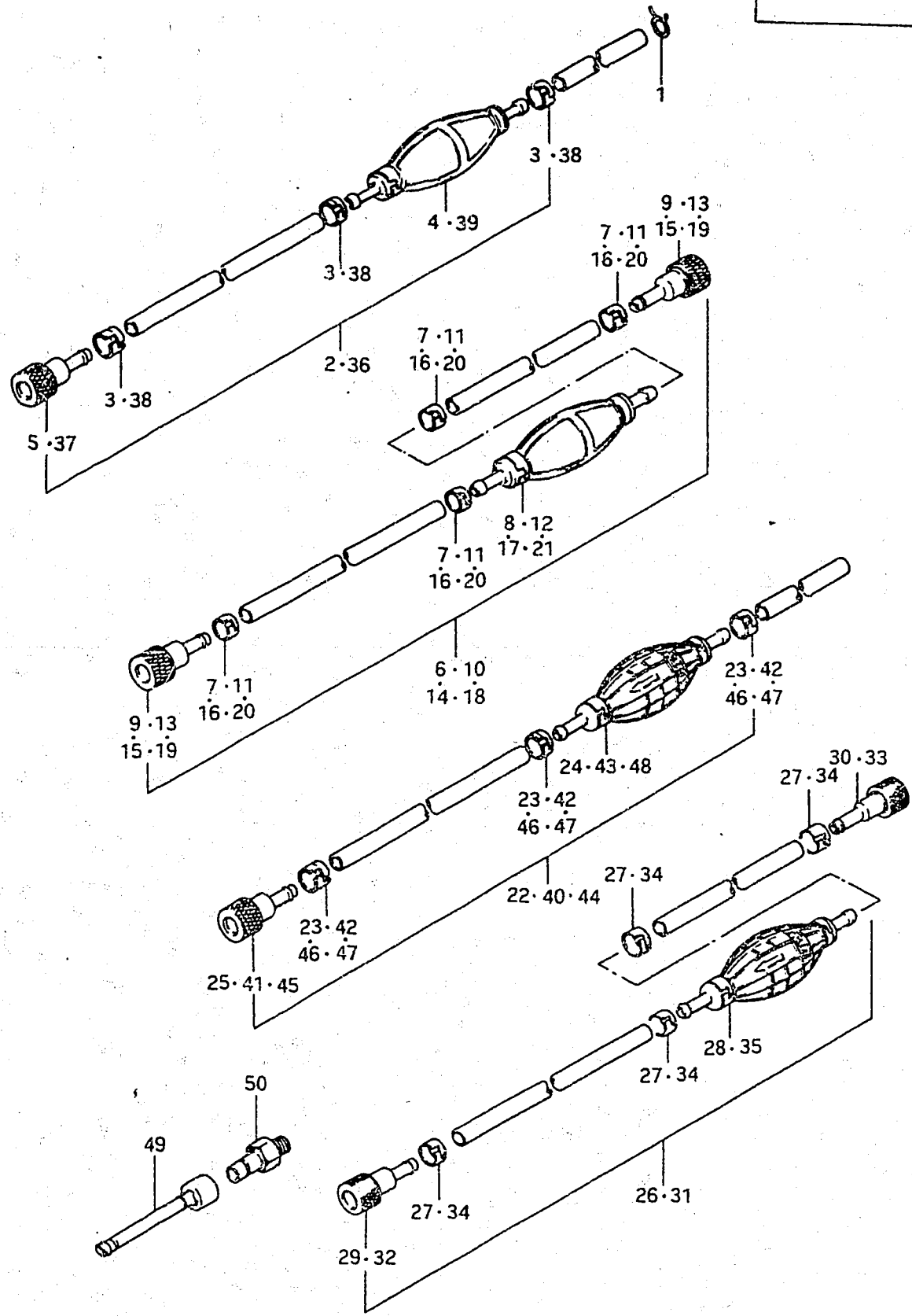

Ref. No.	Part No.	Description	Q'ty		Remarks
			5	8	
31	65700-95204	HOSE ASSY, fuel (L:2550)	-	1	to 65700-95205 DT8J(E9,E13)
32	65750-98505	·SOCKET, fuel hose (ID:11φ)	-	1	
33	65750-93000	·SOCKET, fuel hose (ID:13φ)	-	1	
34	09401-13402	·CLIP	-	4	
35	65770-99702	·PUMP, squeeze	-	1	(J/VZ) E28
36	65700-98520	HOSE ASSY, fuel (L:2550)	1	1	
37	65750-98505	·SOCKET, fuel hose (ID:11φ)	1	1	
38	09401-13402	·CLIP	3	3	L:2520→1953 from 65700-98505
39	65770-98520	·PUMP, squeeze	1	1	
40	65700-98506	HOSE ASSY fuel	1	1	model VZ
41	65750-98505	·SOCKET, fuel hose (ID:11φ)	1	1	
42	65781-98500	·CLIP	3	3	from 65700-98540 DT5W(J/VZ)
43	65770-99702	·PUMP, squeeze	1	1	
44-1	65700-98540	HOSE ASSY, fuel (DT5WJ)	1	-	
44-2	65700-98541	HOSE ASSY, fuel (DT5WVZ)	1	-	DT5W(J/VZ)
45	65750-98505	·SOCKET, fuel hose (ID:11φ)	1	-	
46	09401-13402	·CLIP (DT5WJ)	3	-	OPT
47	65781-98500	·CLIP (DT5WVZ)	3	-	
48	65770-99702	·PUMP, squeeze	1	-	OPT
49	65700-95270	HOSE, fuel joint	1	1	
50	65720-98590	PLAG, fuel connector	1	1	

FIG. 43

G - 9

FIG. 43 OPTIONAL : ELECTRICAL

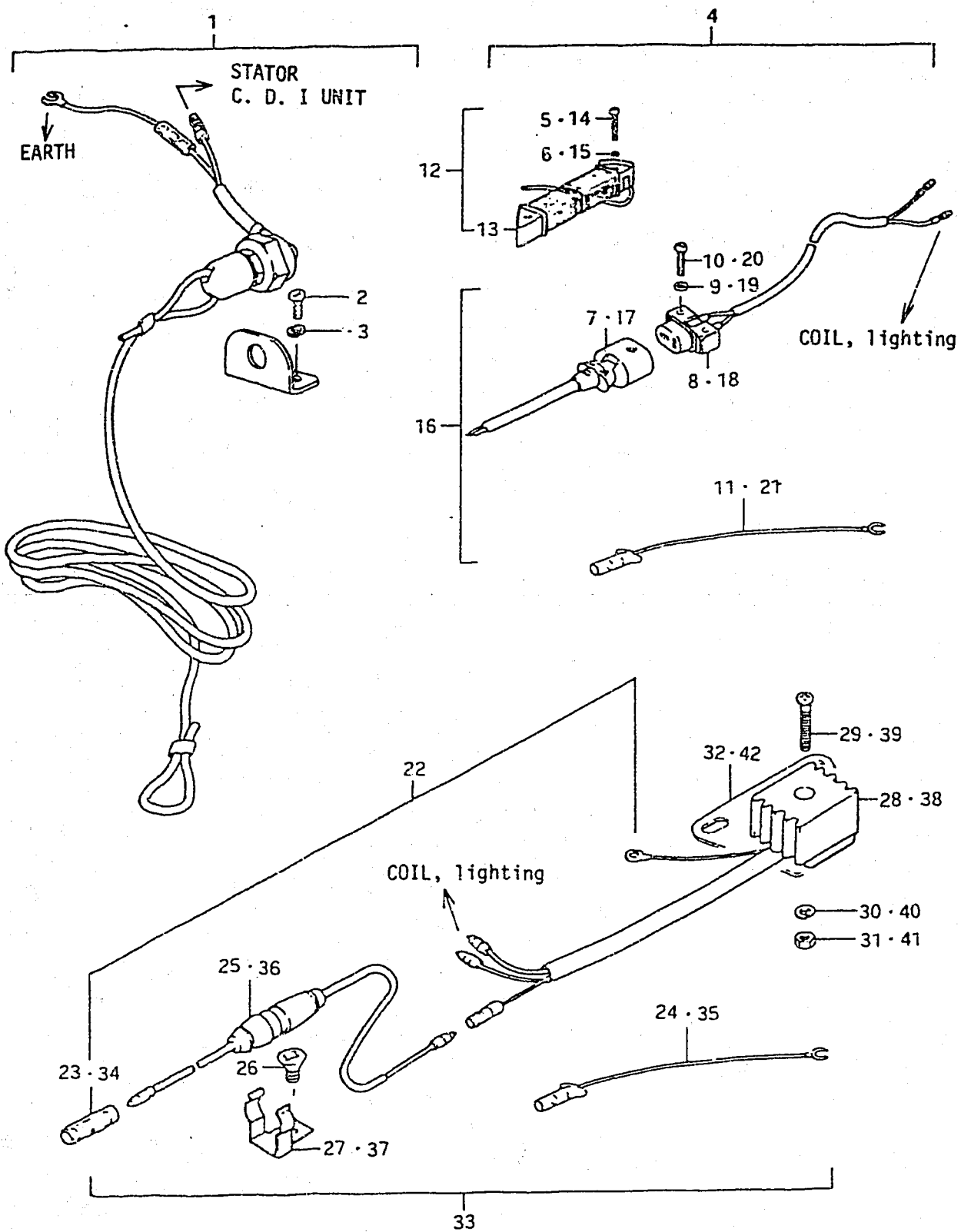

Ref. No.	Part No.	Description	Q'ty	Remarks
1-1	37800-93813	SWITCH SET, emergency	1	model G
1-2	37800-93814	SWITCH SET, emergency	1	from 37800-93813
1-3	37802-98300	SWITCH SET, emergency	1	model J/VZ from 37800-93814
2	09125-04011	•SCREW	2	
3	09162-04002	•LOCK WASHER	2	
4-1	32200-98840	COIL SET, lighting (12V,80W) (COIL SET, battery charging)	1	from 32200-98840
4-2	32200-98841	COIL SET, lighting (12V,80W) (COIL SET, battery charging) to (32200-98100)+(39600-98300)	1	
5	02112-05308	•SCREW	2	
6	08321-21058	•LOCK WASHER	2	
7	39602-99711	•PLUG, lighting	1	model G
8	39601-96712	•SOCKET ASSY, lamp	1	from 39601-96711
9	08322-21048	•WASHER	2	
10	02112-04258	•SCREW	2	
11	36898-93300	•READ WIRE, earth	1	
12	32200-98100	COIL SET, lighting (12V,80W) (COIL SET, battery charging)	1	model J
13	32120-98111	•COIL, lighting (12V,80W) (COIL SET, battery charging)	1	model VZ
14	02112-05308	•SCREW	2	
15	08321-21058	•LOCK WASHER	2	
16	39600-98300	CONSENT ASSY, lamp	1	
17	39602-99711	•PLUG, lighting	1	model J/VZ
18-1	39601-96711	•SOCKET ASSY, lamp	1	model J
18-2	39601-96712	•SOCKET ASSY, lamp	1	model VZ from 39601-96711
19	08322-21048	•WASHER	2	
20	02112-04258	•SCREW	2	
21	36898-93300	•READ WIRE, consent earth	1	

FIG. 43

G - 10

FIG. 43 OPTIONAL : ELECTRICAL

Q'ty

Remarks

Ref. No.	Part No.	Description	Q'ty	Remarks	
22	32800-96811	RECTIFIER SET	1	} model G	
23	37132-93700	•CONNECTOR, read wire	1		
24	36898-93300	•READ WIRE, consent earth	1		
25-1	36740-95251	•CASE ASSY, fuse	1		to 36740-95252
25-2	36740-95252	•CASE ASSY, fuse	1		
26	09125-06020	•SCREW	1		
27	36791-95200	•HOLDER, fuse case	1		
28	32800-95720	•RECTIFIER ASSY	1		
29	02112-05258	•SCREW	1		
30	08321-21058	LOCK WASHER	1		
31	08310-11058	NUT	1	} model J/VZ	
32	32890-98100	STAY, rectifier	1		
33	32801-98100	RECTIFIER SET	1		
34	37132-93700	•CONNECTOR, read wire	1		
35	36898-93300	•READ WIRE, consent earth	1		
36	36740-95252	•CASE ASSY, fuse	1		
37	36791-95200	•HOLDER, fuse case	1		
38	32800-95720	•RECTIFIER ASSY	1		
39	02112-05258	•SCREW	1		
40	08321-21058	•LOCK WASHER	1		
41	08310-11058	•NUT	1		
42	32890-98100	•STAY, rectifier	1		

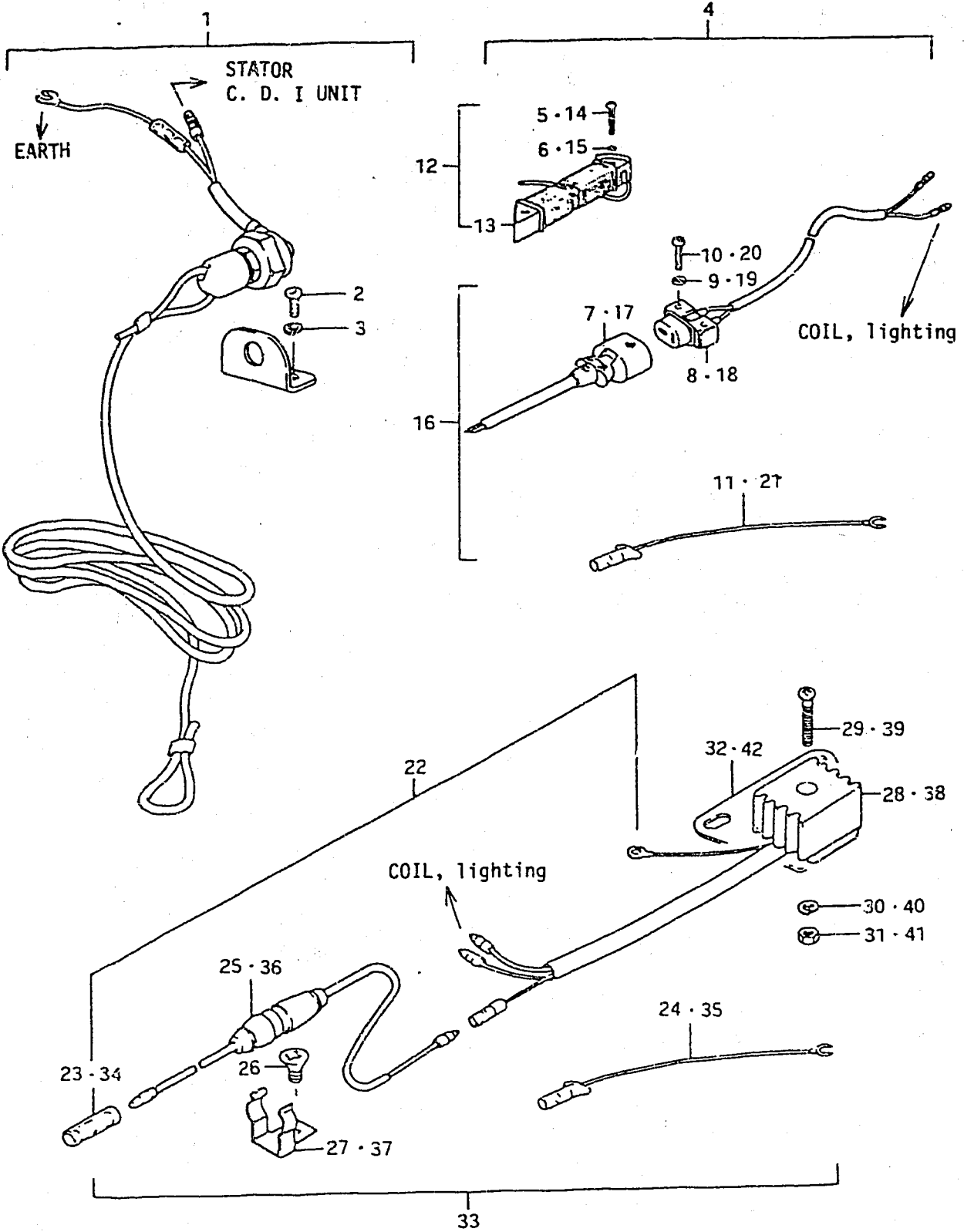
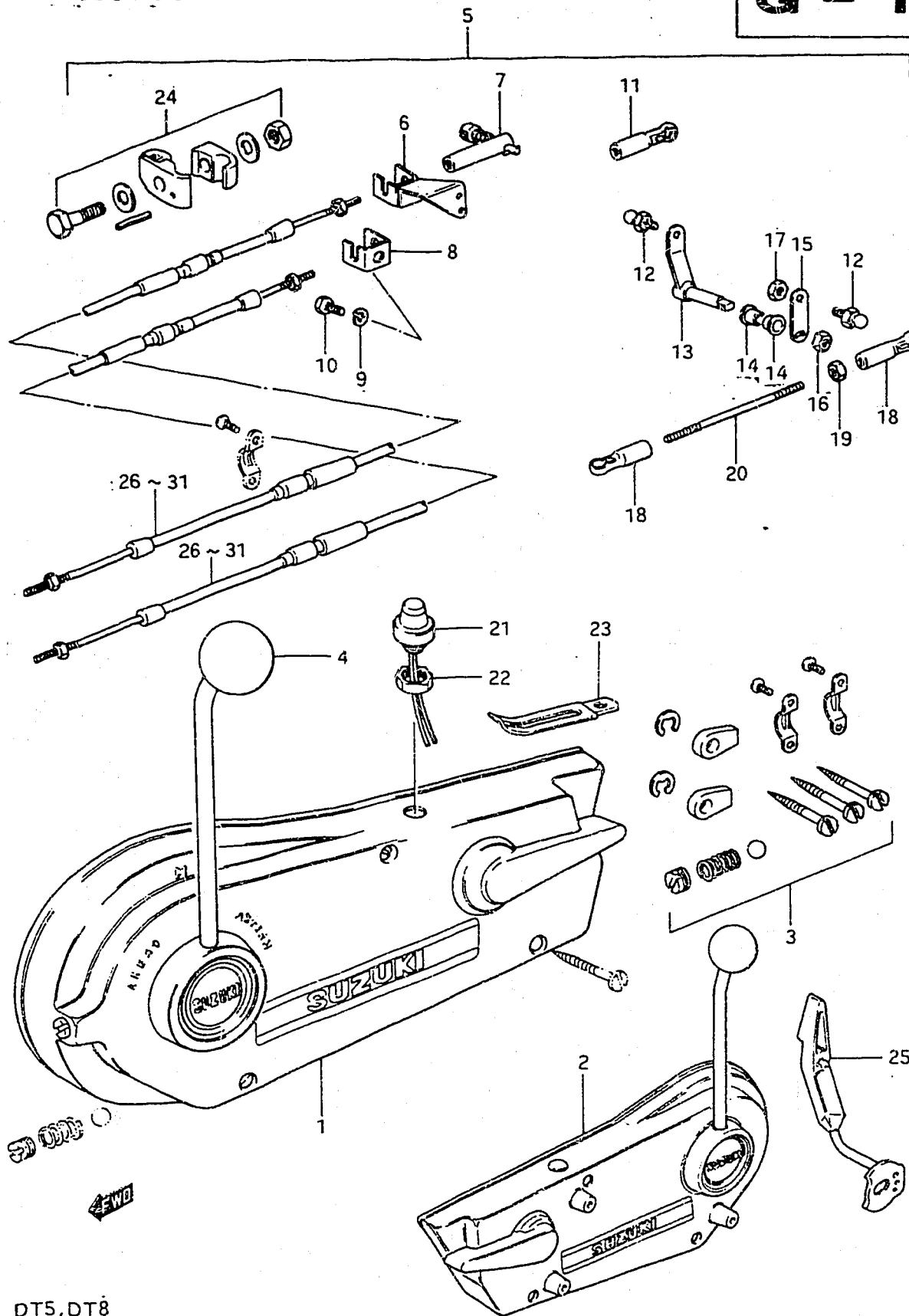

FIG. 44

G - 11

FIG. 44 OPT : REMOTE CONTROL

Q'ty



Ref. No.	Part No.	Description	5/8	Q'ty	Remarks
1	67200-95202	REMOTE CONTROL BOX ASSY	1	1	RH
2	67200-95212	REMOTE CONTROL BOX ASSY	1	1	LH
3	67300-95810	•HOLDER SET	1	1	
4	67214-95200	•KNOB	1	1	
5-1	67130-98100-01J	REMOTE CONTROL PARTS ASSY	1	1	Incl Ref.No.6~23 to 67130-98101-01J
5-2	67130-98101-01J	REMOTE CONTROL PARTS ASSY	1	1	Incl Ref.No.6~24
5-3	67130-98110-01J	REMOTE CONTROL PARTS ASSY	1	1	J(E9,E13) Incl Ref.No.6~23,25
5-4	67130-98111-01J	REMOTE CONTROL PARTS ASSY	1	1	Incl Ref.No.6~25 VZ(E13,E40)
6	67340-98100	•HOLDER, remote control cable	1	1	
7	67440-93701	•GUIDE, clutch cable	1	1	
8	67341-93400	•HOLDER, remote control cable	1	1	
9	09162-06001	•LOCK WASHER	3	3	
10	09100-06019	•BOLT	3	3	
11	67466-95200	•CONNECTOR, cable	1	1	
12	09119-06047	•BALL, pivot	3	3	from 09119-06039
13	67410-98100-01J	•SHAFT, remote control throttle	1	1	
14	63225-93200	•BUSHING	2	2	
15	67417-98100	•ARM, remote control throttle	1	1	
16	09140-08003	•NUT	2	2	
17	09140-06004	•NUT	1	1	
18	67463-95200	•CONNECTOR, throttle control	2	2	
19	09140-05001	•NUT	1	1	
20	67413-98100	•ROD, throttle control	1	1	
21	37800-93750	•SWITCH ASSY, engine stop	1	1	
22	09140-14014	•NUT	1	1	
23	09404-06401	•CLAMP	1	1	
24	19190-98110	•ARM SET	1	1	
25	21110-98101-01J	•LEVER, clutch	1	1	J(E9,E13),VZ(E40)

FIG. 44

G - 12

57

FIG. 44 OPT : REMOTE CONTROL

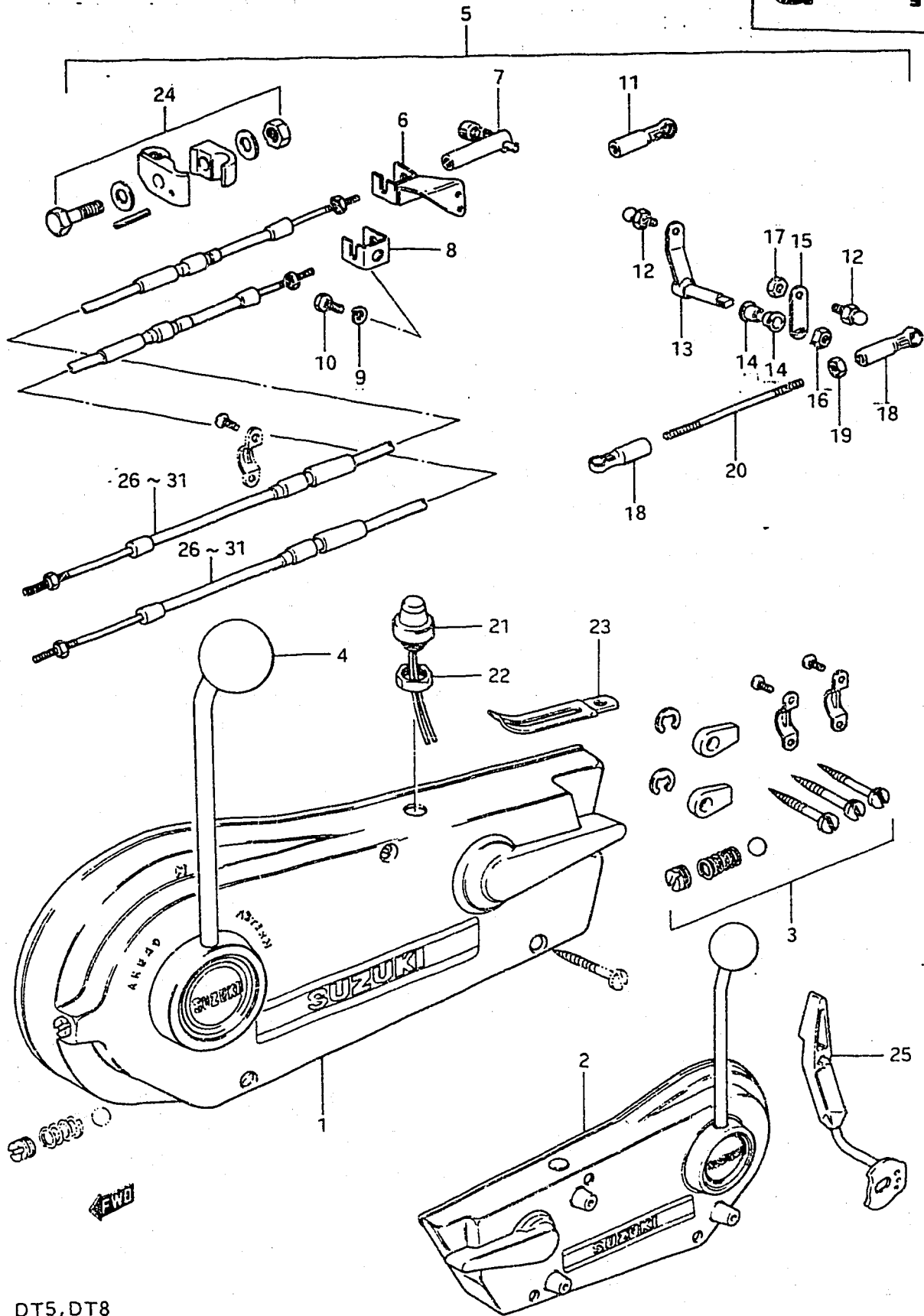

Ref. No.	Part No.	Description	Q'ty	Remarks
26	67320-95750	CABLE ASSY, clutch (L:2500)	2	
27	67320-95740	CABLE ASSY, clutch (L:3000)	2	
28	67320-95730	CABLE ASSY, clutch (L:3500)	2	
29	67320-95720	CABLE ASSY, clutch (L:4000)	2	
30	67320-95710	CABLE ASSY, clutch (L:4500)	2	
31	67320-95200	CABLE ASSY, clutch (L:5000)	2	

FIG. 45

G - 13

FIG. 45 OPTIONAL

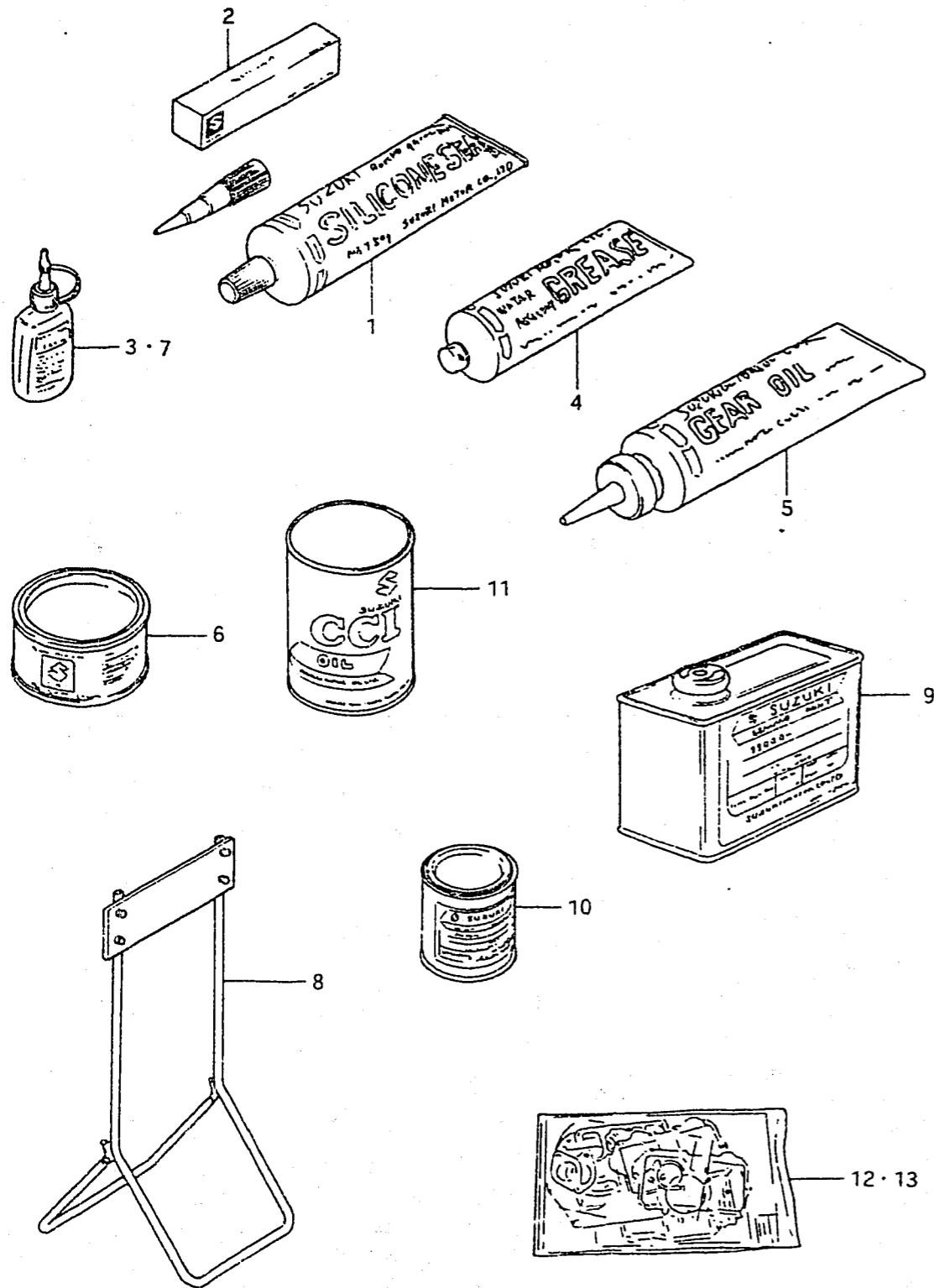

Ref. No.	Part No.	Description	Q'ty		Remarks
			5	8	
1	99000-31120	SUZUKI SILICONE SEAL	1	1	for gear case 50g
2	99000-31050	GASKET, liquid	1	1	for gear case 100g
3	99000-32020	THREAD LOCK SUPER "1333B"	1	1	50g
4-1	99000-25160	GREASE, water resistant	1	1	250g
4-2	99000-25170	GREASE, water resistant	1	1	50g
5	99000-22540	GEAR OIL, outboard motor	1	1	400cc
6	99000-25010	SUZUKI SUPER GREASE A	1	1	450g, for crank oil seal
7	99000-32050	THREAD LOCK "1342"	1	1	50g
8	09914-39911	HANGER, engine	1	1	
9-1	99000-10105-01T	PAINT (Francis White No.2)	1	1	500g
9-2	99000-10205-01J	PAINT (Andes Blue Metallic)	1	1	500g
10-1	99000-10109-01T	PAINT (Francis White No.2)	1	1	90g
10-2	99000-10209-01J	PAINT (Andes Blue Metallic)	1	1	90g
11-1	99000-21460	CCI OIL (12x24)	1	1	Mithubishi
11-2	99000-21145	CCI OIL (12x24)	1	1	Shell
11-3	99000-21021	CCI OIL (42x6)	1	1	
11-4	99000-21150	CCI OIL (2002)	1	1	
11-5	99000-21250	CCI SUPER OIL (12x24)	1	1	
11-6	99000-21260	CCI SUPER OIL (42x6)	1	1	
12-1	11400-98833	ENGINE GASKET SET	1	-	model G to 11400-98834
12-2	11400-98834	GASKET SET (ALL GASKET)	1	-	model J
12-3	11400-98835	GASKET SET (ALL GASKET)	1	-	from 11400-98834 to 11400-98836
12-4	11400-98836	GASKET SET (ALL GASKET)	1	-	
12-5	11400-98837	GASKET SET (ALL GASKET)	1	-	from 11400-98836, model VZ
13-1	11400-98850	ENGINE GASKET SET	-	1	to 11400-98851
13-2	11400-98851	ENGINE GASKET SET	-	1	to 11400-98852
13-3	11400-98852	ENGINE GASKET SET	-	1	model G to 11400-98853
13-4	11400-98853	GASKET SET (ALL GASKET)	-	1	model J/VZ