



SUZUKI MARINE

Parts Book

DT 60 (1983)



1703 Hwy 35 So., Laurence Harbor, NJ 08879

(732) 264-7176

(800) 338-0645 FAX (732) 264-2472

www.brownspoint.com

PREFACE

When it becomes necessary to replace parts on SUZUKI OUTBOARD MOTORS, always use SUZUKI GENUINE PARTS which have passed a strict inspection which guarantees quality and performance.

This parts catalogue covers the list of all service parts for SUZUKI DT60 QD. The basic model of this parts catalogue is DT60 O/I QD.

INSTRUCTIONS FOR QUOTING THE CATALOGUE

1. DIMENSIONS

Dimensions of the parts in this catalogue are indicated in unit millimeters.

2. ABBREVIATIONS

Abbreviations used in this catalogue are as follows:

AR	: As required	NT	: Number of teeth
ASSY	: Assembly	OPT	: Optional
E.No.	: Engine number	OS	: Over size
F.No.	: Frame number	STD	: Standard
d	: Diameter of material	T	: Thickness
ID	: Inside diameter	US	: Under size
OD	: Outside diameter	W	: Width
L	: Length	S,L,UL,LL	: Transom type
LH	: Left hand side		
RH	: Right hand side		

$\frac{12}{\text{ID}} \times \frac{34}{\text{OD}} \times \frac{5.6}{\text{T(or W,L)}}$ Figures in the description column show the dimensions of parts.

ID OD T(or W,L)

3. INNER PARTS OF ASSEMBLY

Part name with a dot (.) in front as shown in the description column indicates the component of the assembly also available individually.

4. MODIFICATION NOTICE

A parts bulletin will be sent to you on all occasions when changes in parts occur, including interchangeable modifications between new parts and old ones.

5. NOTE

5-1. There are some different parts from those of production models among spare parts for the administrative reasons and common use of them with other models.

5-2. In respect of rubber hoses and vinyl tubes, please be sure to use them by cutting off according to the length mentioned on parts catalogue or what is actually required on the vehicle.

5-3. Note that the drawings on the illustration page are for ready reference of spare parts number, not to be used as an assembly manual. When assembling, use "SUZUKI SERVICE MANUAL".

6. ENGINE NUMBER

DT60 O/I QD : 06001-301001-

FIG.1 (B- 2) CYLINDER

FIG.1

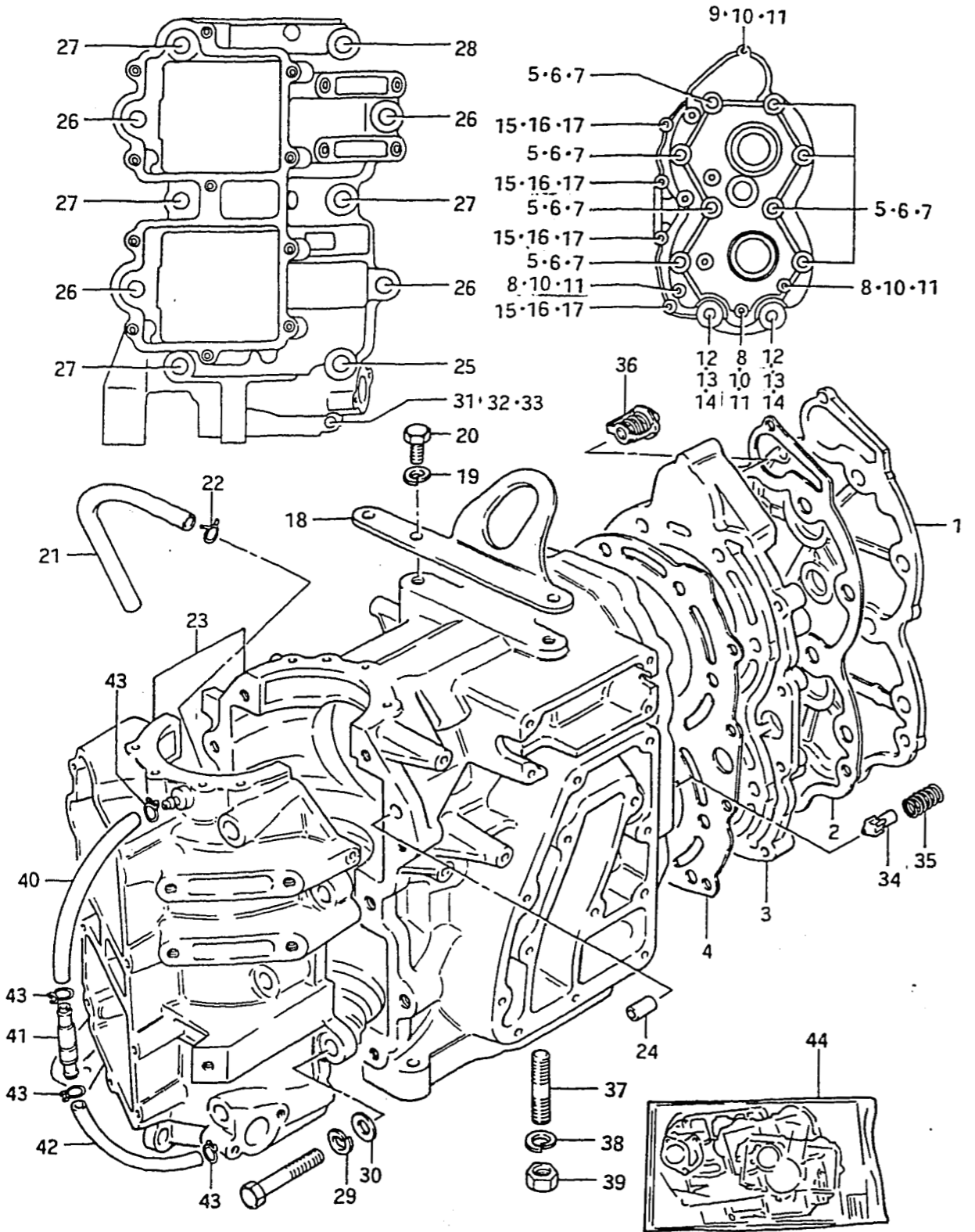

REF.NO.	PART NO.	DESCRIPTION	Q'TY	REMARKS
1	11161-95202-02M	COVER, cylinder head	1	
2	11162-95201	GASKET, cylinder head cover	1	
3	11111-95321-02M	CYLINDER HEAD	1	
4	11141-95304	GASKET, cylinder head	1	
5	01107-10808	BOLT	8	
6	08321-21108	LOCK WASHER	8	
7	08322-11108	WASHER	8	
8	01107-06258	BOLT	3	
9	01107-06308	BOLT	1	
10	08321-21068	LOCK WASHER	4	
11	08322-21068	WASHER	4	
12	09119-10016	BOLT	2	
13	08321-21108	LOCK WASHER	2	
14	08322-11108	WASHER	2	
15	09100-06033	BOLT	4	
16	08321-21068	LOCK WASHER	4	
17	08322-21068	WASHER	4	
18	11291-95203	HOOK, engine	1	
19	08321-21088	LOCK WASHER	2	
20	01107-08208	BOLT	2	
21	09343-03051	HOSE, inspection (L:235-180)	1	
22	09401-06403	CLIP	2	

FIG.1 (B- 3) CYLINDER

FIG.1

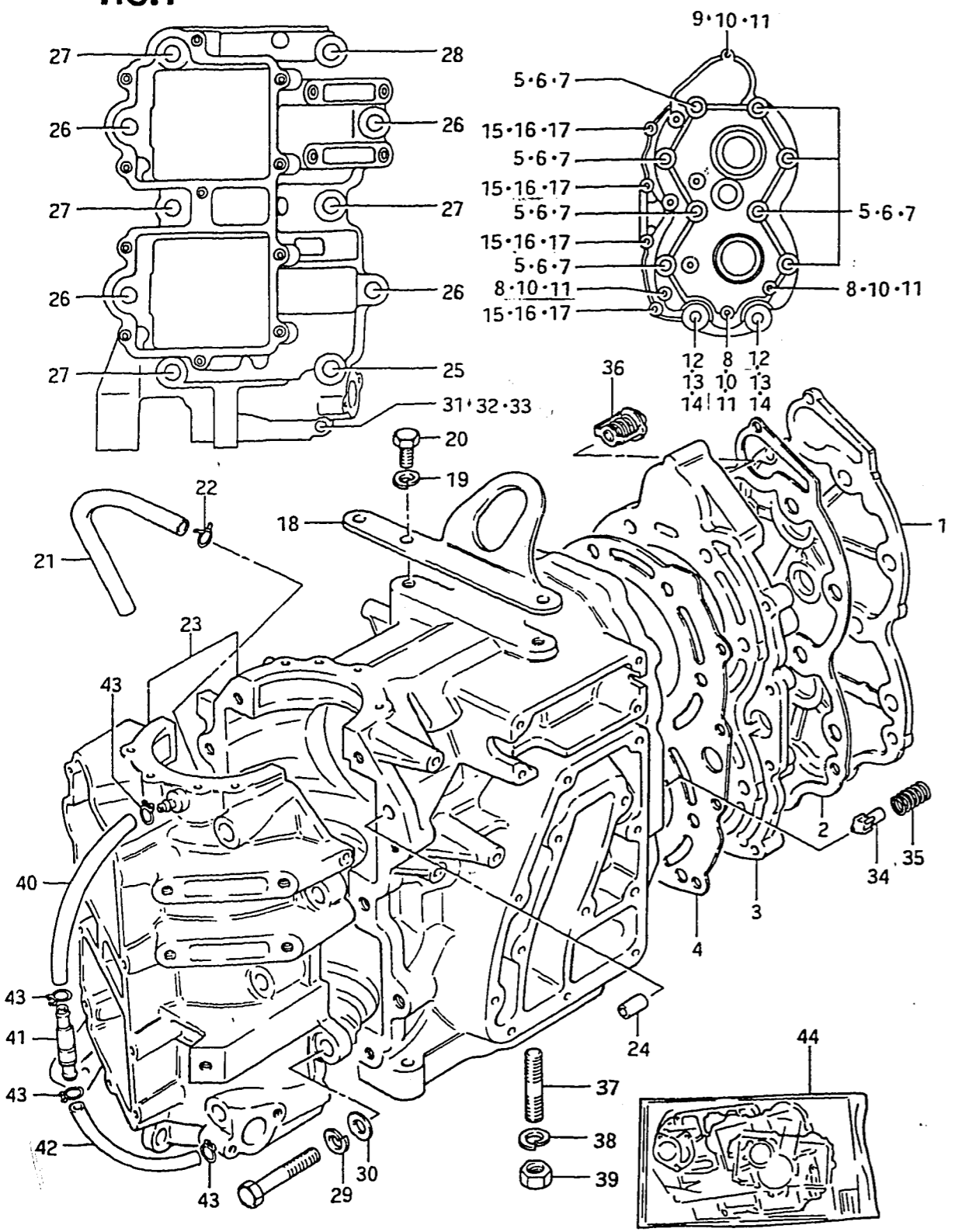

REF.NO.	PART NO.	DESCRIPTION	Q'TY	REMARKS
23	11301-95322-02M	CYLINDER/CRANKCASE ASSY	1	
24	04211-09109	.DOWEL PIN	2	
25	01107-10858	.BOLT	1	
26	01107-10408	.BOLT	4	
27	01107-10608	.BOLT	4	
28	01107-10708	.BOLT	1	
29	08321-21108	.LOCK WASHER	10	
30	08322-11108	.WASHER	10	
31	01107-06408	.BOLT	1	
32	08321-21068	.LOCK WASHER	1	
33	08322-21068	.WASHER	1	
34	17611-95201	VALVE, water bypass	1	
35	09440-11008	SPRING	1	
36	17670-95300	THERMOSTAT	1	
37	09108-08029	STUD BOLT (8x40)	1	
38	09162-08003	LOCK WASHER	1	
39	09140-08003	NUT	1	
40	09343-03051	HOSE, lubrication (L:235*180)	1	
41	16710-95200	CHECK VALVE	1	
42	09343-03051	HOSE, lubrication (L:235*100)	1	
43	09401-06403	CLIP	4	
44	11401-95812	GASKET SET	1	OPT

FIG.2 (B- 4) CRANKSHAFT

FIG.2

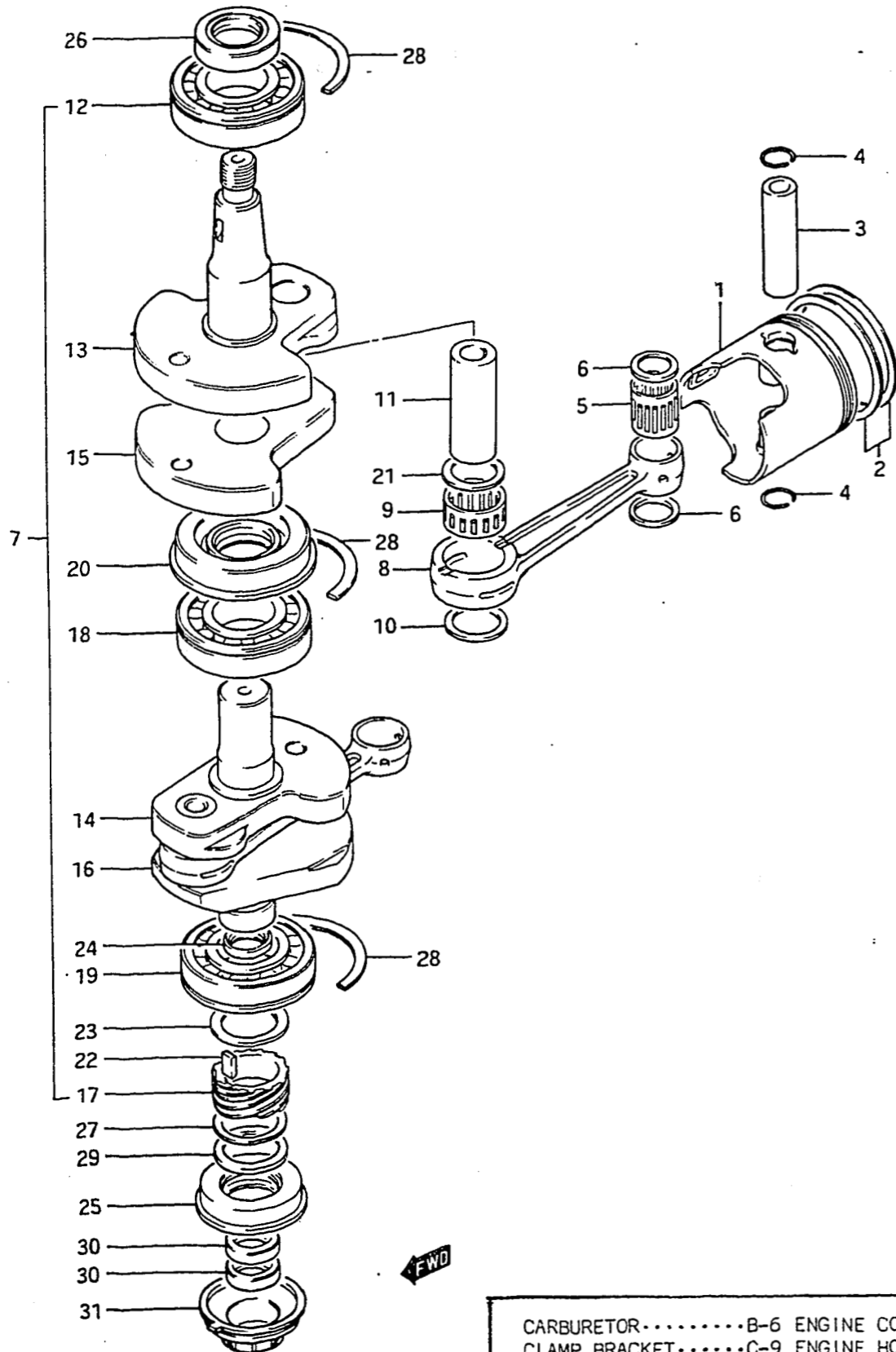

REF.NO.	PART NO.	DESCRIPTION	Q'TY	REMARKS
1-1	12110-95511	PISTON (STD)	2	
1-2	12110-95511-025	PISTON (OS:0.25)	2	OPT
1-3	12110-95511-050	PISTON (OS:0.5)	2	OPT
2-1	12140-95301	RING SET, piston (STD)	2	
2-2	12140-95301-025	RING SET, piston (OS:0.25)	2	OPT
2-3	12140-95301-050	RING SET, piston (OS:0.5)	2	OPT
3	12151-95500	PIN, piston	2	
4	09381-20001	CIRCLIP, piston pin	4	
5	09263-20034	BEARING, piston pin	2	20x25x27.9
6	09169-20001	WASHER, connecting rod	4	
7	12200-95303	CRANKSHAFT ASSY	1	
8	12161-95301	.ROD, connecting	2	
9	09263-28018	.BEARING, crank pin	2	
10	09160-28019	.WASHER, crank pin No.1	2	
11	12211-95501	.PIN, crank	1	
12	09264-35002	.BEARING, crankshaft upper	1	
13	12221-95303	.CRANKSHAFT, upper	1	
14	12232-95301	.WHEEL, middle lower	1	
15	12231-95301	.WHEEL, middle upper	1	
16	12241-95304	.CRANKSHAFT, under	1	
17	16321-95301	.GEAR, oil pump drive	1	
18	09262-30065	.BEARING, crankshaft middle	1	
19	09262-35023	.BEARING, crankshaft under	1	
20	09289-45001	.OIL SEAL, crankshaft middle	1	
21	08211-28361	.WASHER, crank pin No.2	2	
22	09421-08001	.KEY, oil pump	1	
23	08211-30422	.WASHER, gear No.2	1	
24	09285-17002	SEAL, crankshaft under	1	
25	09283-30045	OIL SEAL, under crankshaft	1	
26	09283-35021	OIL SEAL, upper crankshaft	1	
27	08211-30401	WASHER, gear No.1	1	
28	09390-72008	RING, thrust	2	
29	08331-11308	CIRCLIP, crankshaft under brg	1	
30	09282-17004	OIL SEAL, drive shaft upper	2	17x28x6
31	11431-95300	HOUSING, lower oil seal	1	

CARBURETOR.....B-6 ENGINE COVER.....D-9 LOWER COVER.....D-7 THROTTLE LINK.....C-3
 CLAMP BRACKET.....C-9 ENGINE HOLDER.....D-2 MAGNETO.....C-5 TRANSMISSION.....D-5
 CLUTCH.....C-2 FUEL PUMP.....B-8 OIL PUMP.....B-9 UPPER OIL SEAL HOUSING.....B-7

FIG.3

FIG.3 (B- 5) INLET CASE / EXHAUST COVER

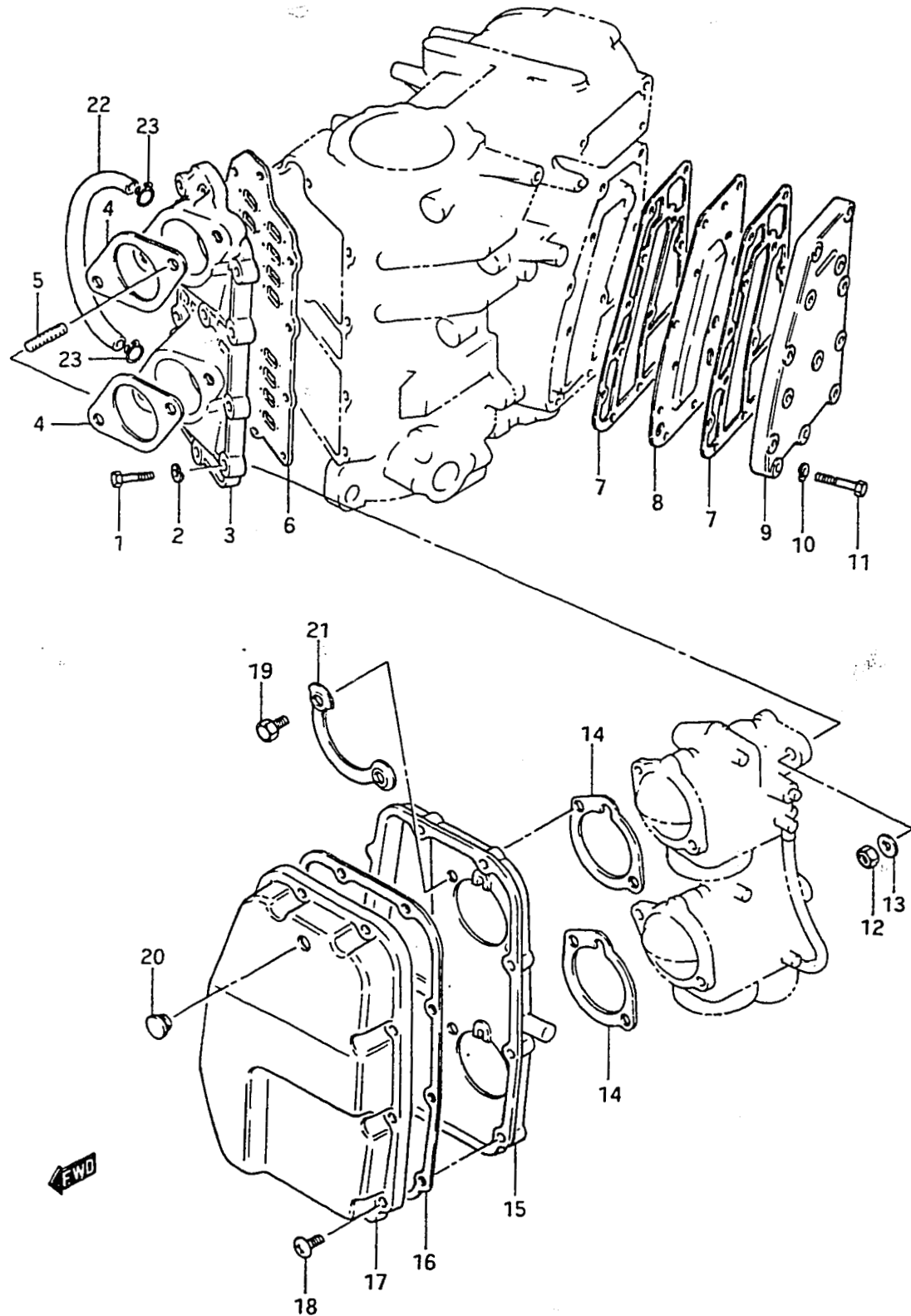

REF.NO.	PART NO.	DESCRIPTION	Q'TY	REMARKS
1	01107-06308	BOLT	11	
2	08321-21068	LOCK WASHER	11	
3	13110-95302-02M	CASE, inlet	1	
4	13125-95200	GASKET, carburetor	2	
5	01411-08208	STUD BOLT	2	
6	13150-95300	VALVE ASSY, reed	1	
7	14151-95200	GASKET, exhaust cover	2	
8	14131-95200	PLATE, exhaust cover	1	
9	14141-95200-02M	COVER, exhaust	1	
10	08321-21068	LOCK WASHER	13	
11	01107-06308	BOLT	13	
12	08310-22088	NUT	4	
13	08322-11088	WASHER	4	
14	13855-95200	GASKET, silencer	2	
15	13811-95310	CASE, silencer	1	
16	13853-95310	GASKET	1	
17	13812-95310	COVER, upper	1	
18	09128-05007	SCREW	9	
19	01107-06128	BOLT	4	
20	09250-10010	PLUG, cover	2	
21	09169-06027	WASHER, silencer	2	
22	09343-05129	HOSE, inlet case	1	
23	09401-09402	CLIP, inlet case hose	2	

FIG.4 . (B- 6) CARBURETOR

FIG.4

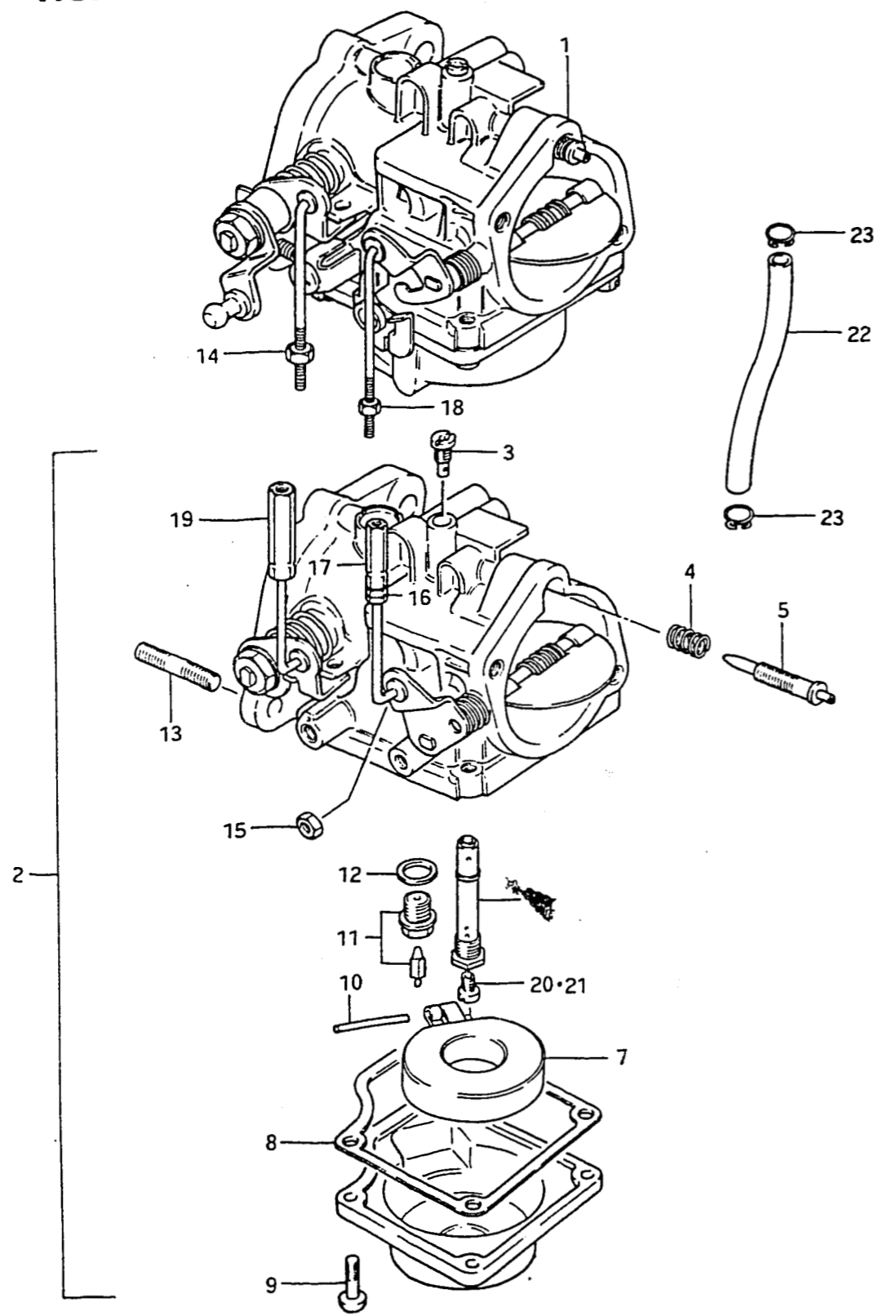

REF.NO.	PART NO.	DESCRIPTION	Q'TY	REMARKS
1	13201-95351	CARBURETOR, top	1	
2	13202-95351	CARBURETOR, 2nd	1	
3	09492-90002	.JET, pilot	2	
4	13271-93311	.SPRING, air screw	2	
5	13269-95210	.ADJUSTER	2	
6	13235-95210	.NOZZLE	2	
7	13256-93012	.FLOAT	2	
8	13251-95210	.GASKET	2	
9	13249-95510	.SCREW	8	
10	13254-93010	.PIN, float	2	
11	13370-28110	.VALVE ASSY, needle	2	
12	13392-58600	.GASKET, valve seat	2	
13	01411-C8208	.STUD BOLT	2	
14	13582-95216	.NUT (Top carbu)	1	
15	13582-95216	.NUT (2nd carbu)	1	
16	13599-95212	.NUT (2nd carbu)	1	
17	13599-95211	.NUT (2nd carbu)	1	
18	13599-95210	.NUT (Top carbu)	1	
19	13582-95219	.NUT (2nd carbu)	1	
20	09491-32006	.JET, main (160)	2	
21-1	09491-33004	JET, main (165)	2	OPT
21-2	09491-31003	JET, main (155)	2	OPT
21-3	09491-30008	JET, main (150)	2	OPT
22	09343-05137	HOSE, fuel (L:500-135)	1	
23	09401-09402	CLIP, fuel hose	2	

FIG.5 (B- 7) UPPER OIL SEAL HOUSING

FIG.5

Q'TY

REMARKS

REF.NO.	PART NO.	DESCRIPTION	Q'TY	REMARKS
1	11411-95312-02M	HOUSING, upper oil seal	1	
2	11421-95200	GASKET, oil seal housing	1	
3	02122-06168	SCREW	6	
4	31911-95300-02M	BRACKET, motor upper	1	
5	08322-11088	WASHER	4	
6	01107-08208	BOLT	4	
7	08321-21088	LOCK WASHER	2	
8	01107-08258	BOLT	2	

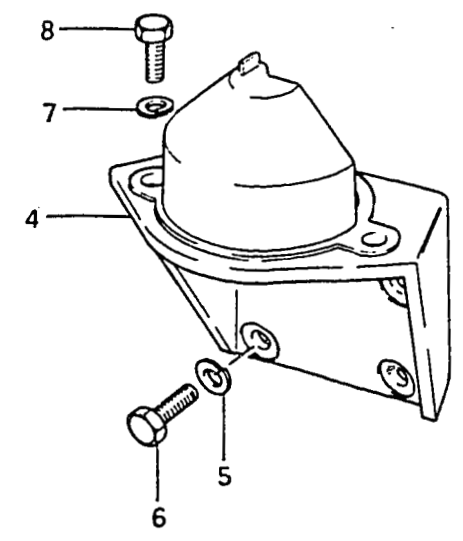
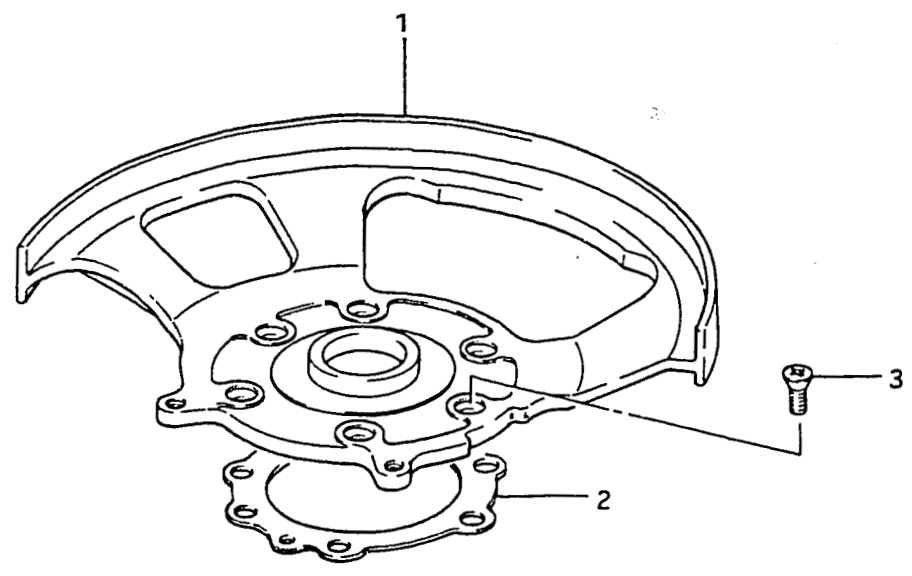
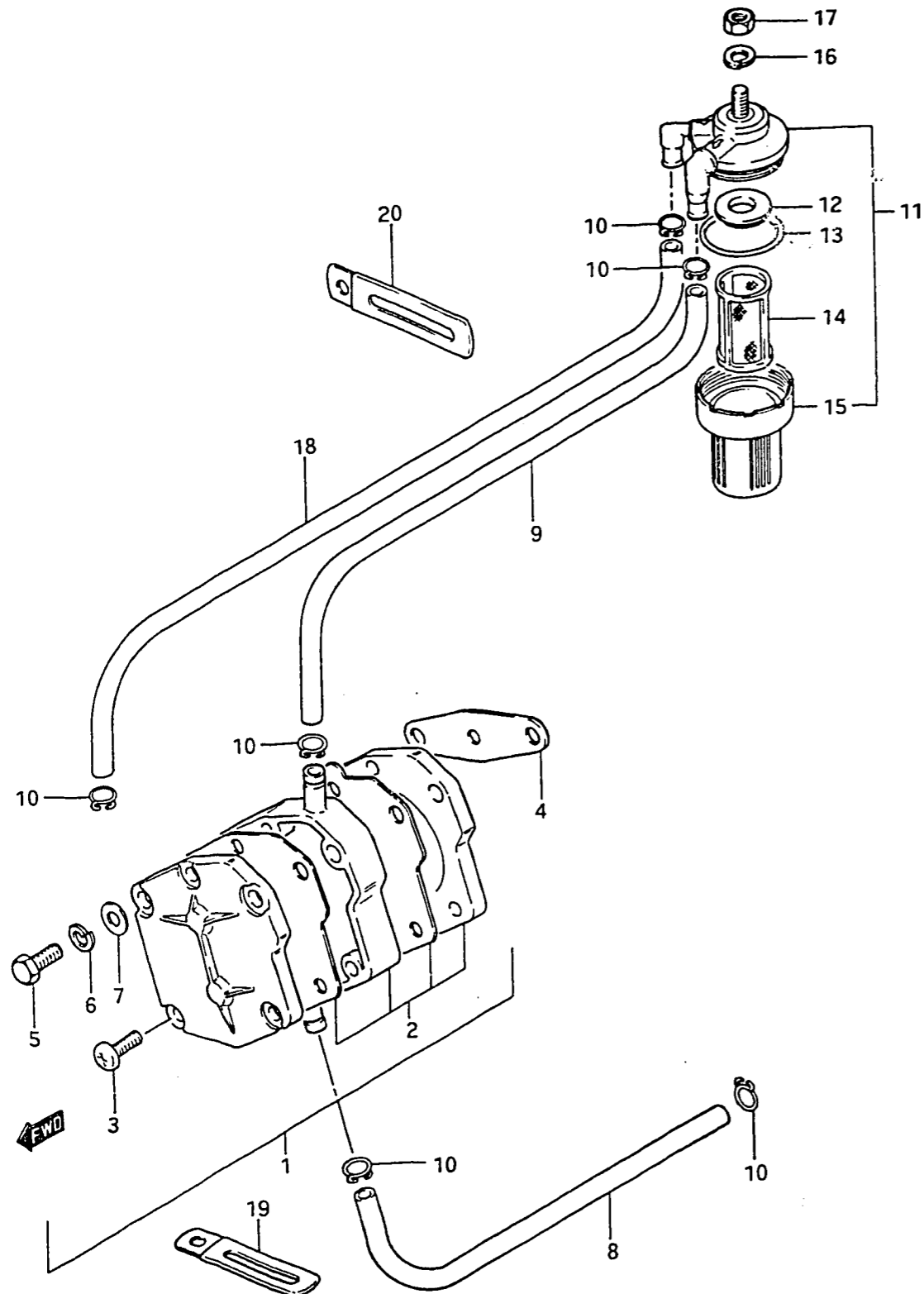

FIG.6 (B- 8) FUEL PUMP

FIG.6

Q'TY

REMARKS



REF.NO.	PART NG.	DESCRIPTION	Q'TY	REMARKS
1	15100-94301	PUMP ASSY, fuel	1	
2	15170-94311	.DIAPHRAGM SET	1	
3	15851-94300	.SCREW	3	
4	15321-99700	GASKET	2	
5	01107-06508	BOLT	2	
6	08321-21068	LOCK WASHER	2	
7	08322-21068	WASHER	2	
8	09343-05137	HOSE, fuel (pump-carbu)	1	L:500-450
9	09343-05137	HOSE, fuel (filter-pump)	1	L:500-75
10	09401-09402	CLIP, fuel hose	6	
11	15410-93400	FILTER ASSY, fuel	1	
12	15416-93400	.PACKING	1	
13	15415-93400	.O RING	1	
14	15412-93400	.STRAINER	1	
15	15413-93400	.CUP	1	
16	08321-21088	LOCK WASHER	1	
17	08310-22088	NUT	1	
18	09343-05137	HOSE, fuel (connector-filter)	1	L:500-420
19	09404-06413	CLAMP (L:70)	1	
20	09404-06404	CLAMP (L:80)	1	

FIG.7

Q'TY

REMARKS

REF.NO.	PART NO.	DESCRIPTION	Q'TY	REMARKS
1	16100-95301	PUMP ASSY, oil	1	
2	09401-06405	CLIP	4	
3	09344-02013	HOSE, outlet (L:350)	2	
4	16911-94500	PROTECTOR (L:340)	2	
5	16731-95300	GASKET	1	
6	16340-95301	RETAINER, driven gear	1	
7	16331-95303	GEAR, driven	1	
8	08322-21058	WASHER	1	
9	16420-95301	CABLE, oil pump	1	
10	09119-05013	BOLT	1	
11	01107-05208	BOLT	1	
12	08322-21058	WASHER	1	
13	09404-06413	CLAMP	1	

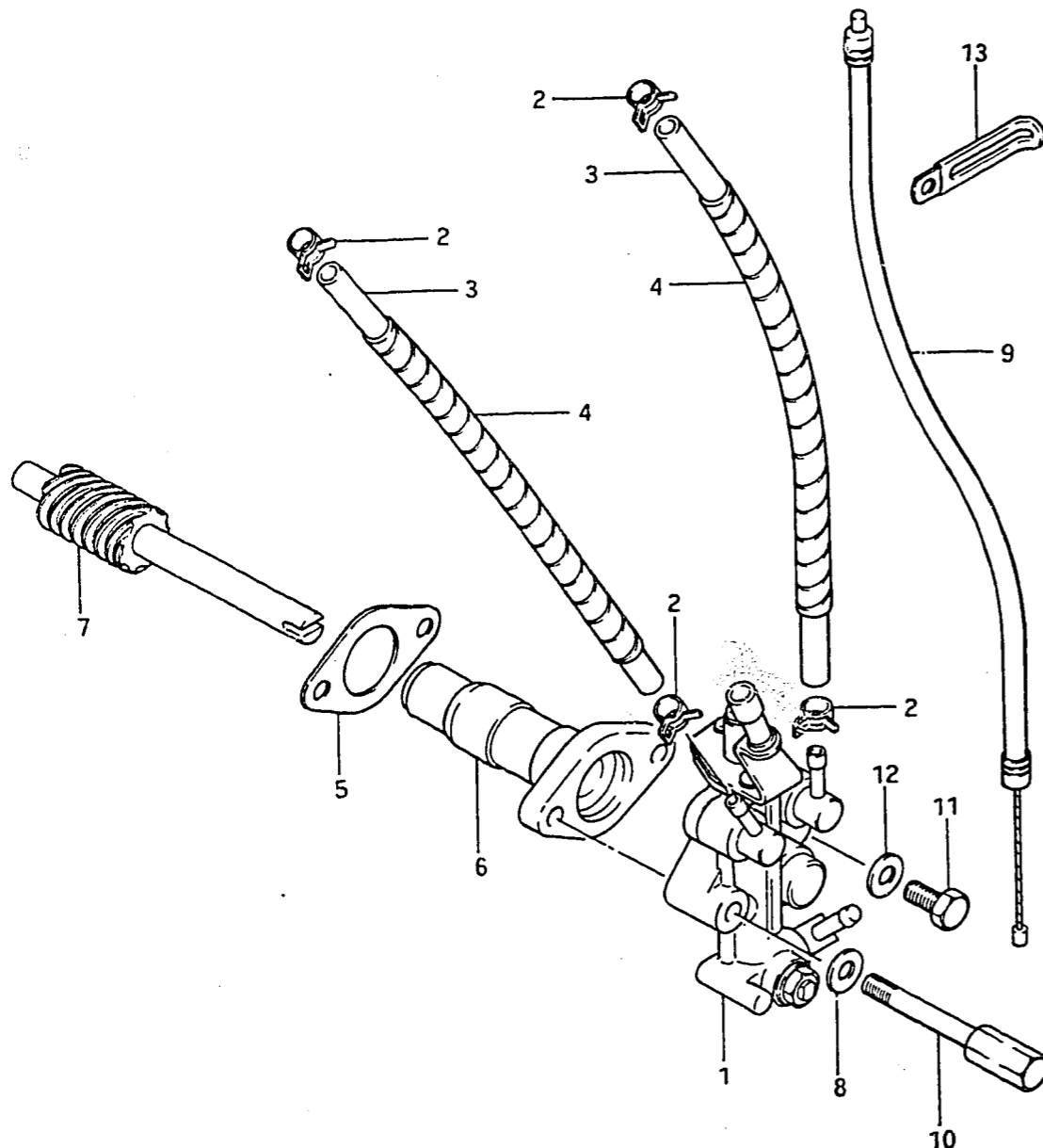

FIG. 8

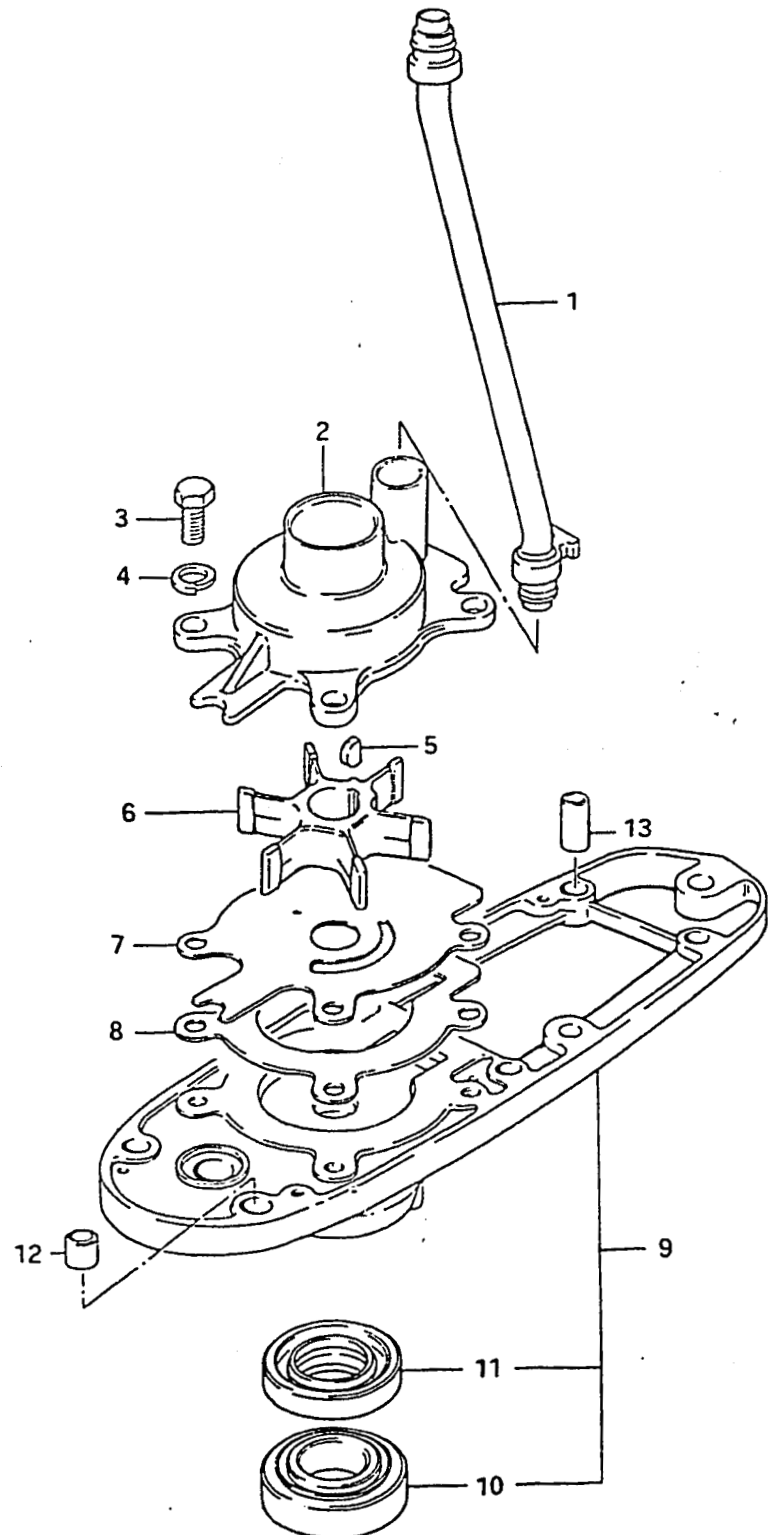

FIG. 8 (B-10) WATER PUMP

REF.NO.	PART NO.	DESCRIPTION	Q'TY	REMARKS
1	17560-95500	TUBE, water	1	
2	17411-95204	CASE, water pump	1	
3	09100-08139	BOLT	4	
4	09162-08003	LOCK WASHER	4	
5	09420-04005	KEY	1	
6	17461-95200	IMPELLER, water pump	1	
7	17471-95203	PLATE, pump case lower	1	
8	17472-95300	GASKET	1	
9	56130-95212-02M	HOUSING, driveshaft bearing	1	
10	09265-17003	.BEARING, drive shaft	1	
11	09289-17005	.OIL SEAL, drive shaft	1	
12	09206-11001	DOWEL PIN (OD:11,L:12)	1	
13	09206-11005	DOWEL PIN (OD:11,L:20)	1	

FIG. 9

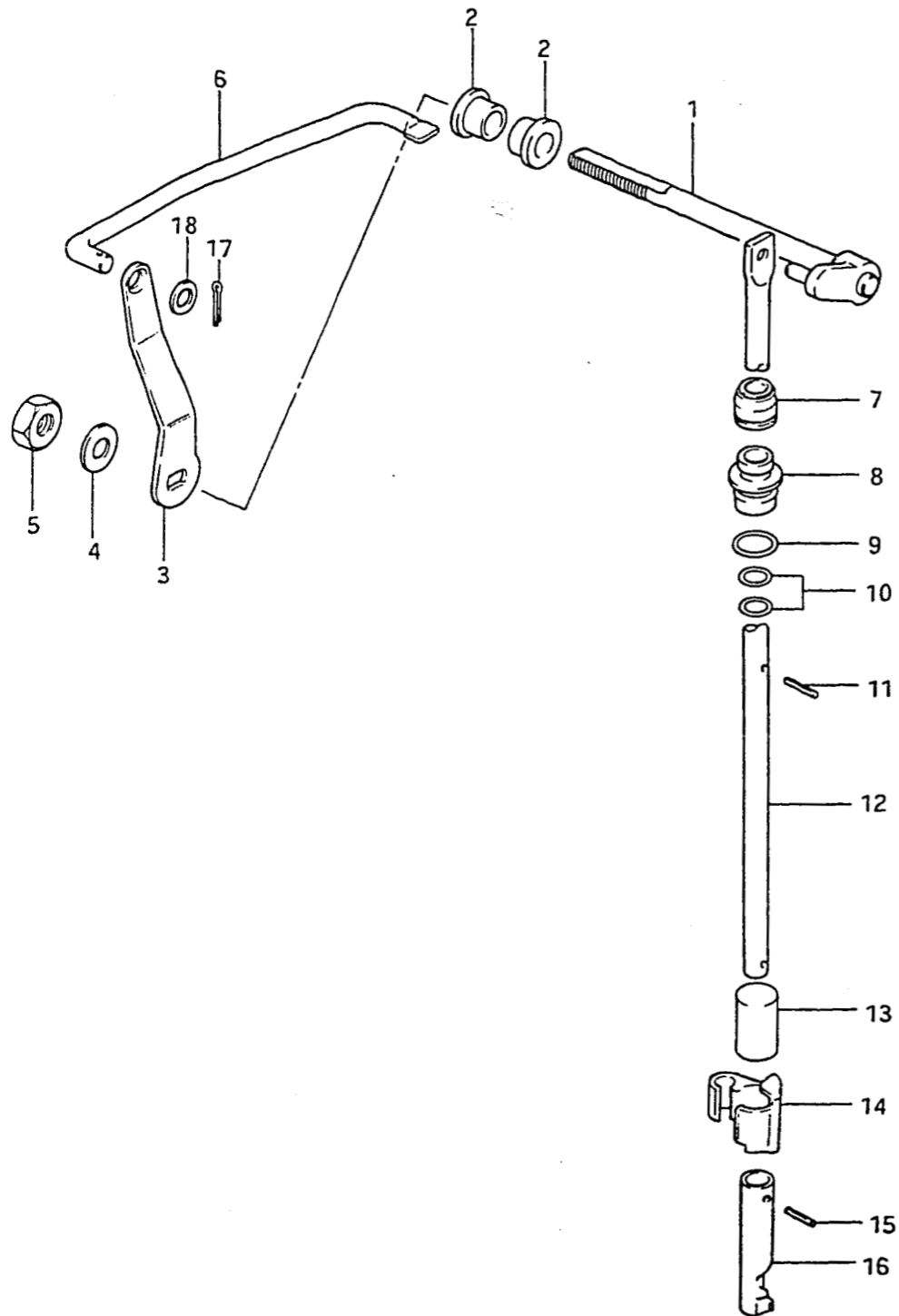
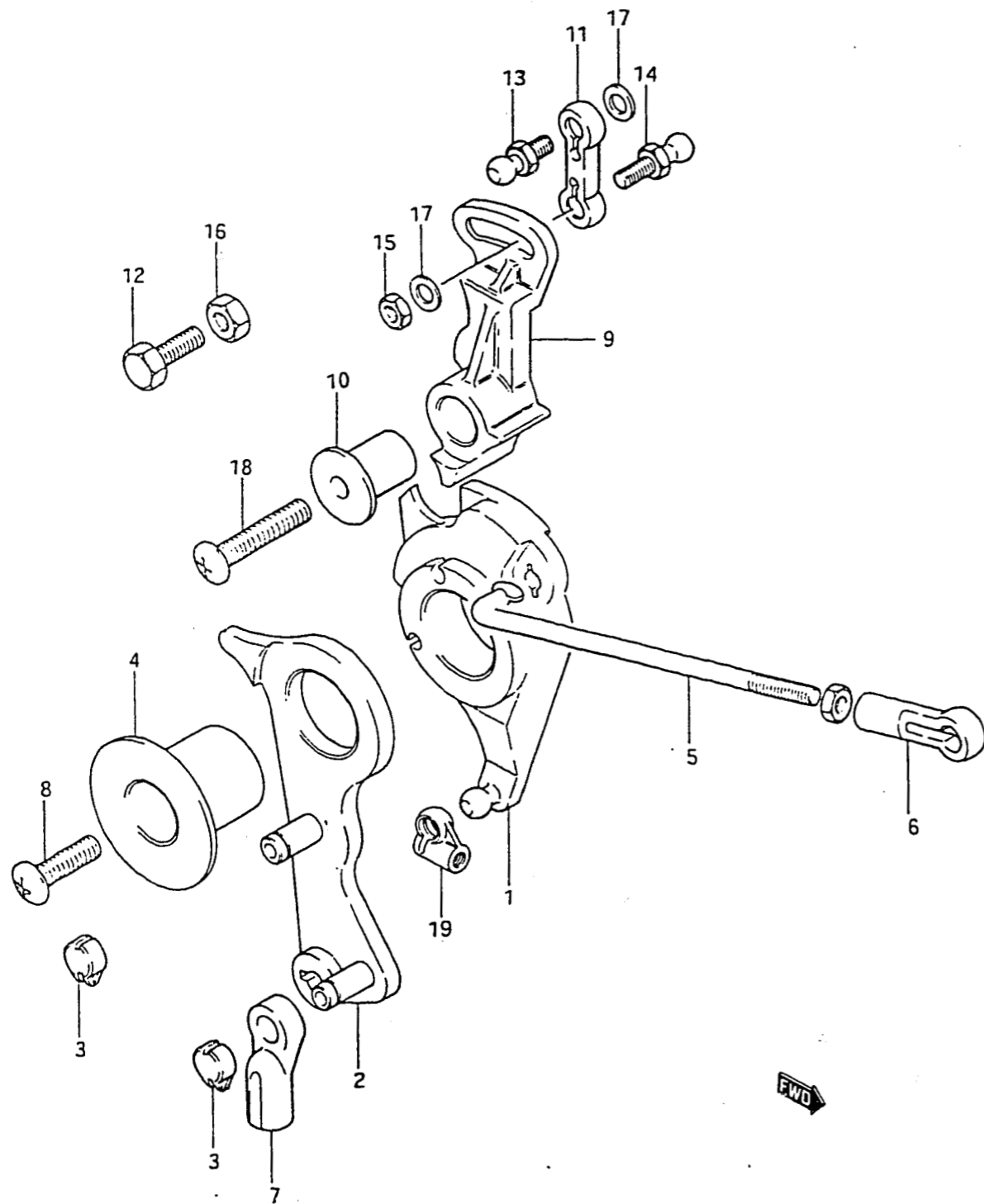

FIG. 9 (C- 2) CLUTCH

REF.NO.	PART NO.	DESCRIPTION	Q'TY	REMARKS
1	21210-95201	SHAFT, clutch	1	
2	09306-08003	BUSHING, clutch shaft	2	
3	21213-95301	ARM, clutch shaft side	1	
4	09160-08015	WASHER, clutch shaft	1	8.5x16x1.6
5	09140-08012	NUT, clutch shaft	2	
6	23111-95301	LINK, clutch	1	
7	25223-95200	DUST SEAL	1	
8	25211-95202	GUIDE, shifting	1	
9	09280-11001	O RING, shifting rod guide	1	
10	09280-08005	O RING, shifting rod guide	2	ID:7.6,d:1.8
11	09205-02004	PIN, clutch rod (2.8x12)	1	
12	25111-95204	ROD, clutch	1	
13	25232-95501	MAGNETO	1	
14	25231-95501	HOLDER, magneto	1	
15	09205-03021	PIN, clutch rod (3.9x12)	1	
16	25311-95201	CAM, clutch	1	
17	09385-06003	PIN, link snap	1	
18	08322-21068	WASHER, link clutch	1	

FIG.10



DT60 O/I QD E3

11

FIG.10 (C- 3) THROTTLE LINK

REF.NO.	PART NO.	DESCRIPTION	Q'TY	REMARKS
1	19111-95302	LEVER, throttle control	1	
2	19112-95302	LEVER, clutch control	1	
3	19113-95300	CAP, connector	3	
4	19114-95300	BUSH, throttle lever	1	
5	19135-95310	ROD, throttle lever	1	
6	67463-95200	CONNECTOR, throttle control	1	
7	67467-95201	CONNECTOR, remoon cable	1	
8	02142-06258	SCREW, clutch control stopper	1	
9	19115-95301	LEVER, spark advance	1	
10	19116-95300	BUSH, advance lever	1	
11	67468-95301	CONNECTOR, spark advance	1	
12	09100-06083	BOLT, advance adjustment	1	
13	09119-05010	PIVOT, stator ball	1	
14	09119-05011	PIVOT, advance lever ball	1	
15	09140-05001	NUT, ball pivot	1	
16	09140-06004	NUT, advance adjustment	1	
17	09162-05002	WASHER, ball pivot lock	1	
18	02142-06357	BOLT, spark advance lever	1	
19	67467-95301	CONNECTOR, remooncable	1	

C3

DT60 O/I QD E3

FIG.11 (C- 4) STARTING MOTOR

FIG.11

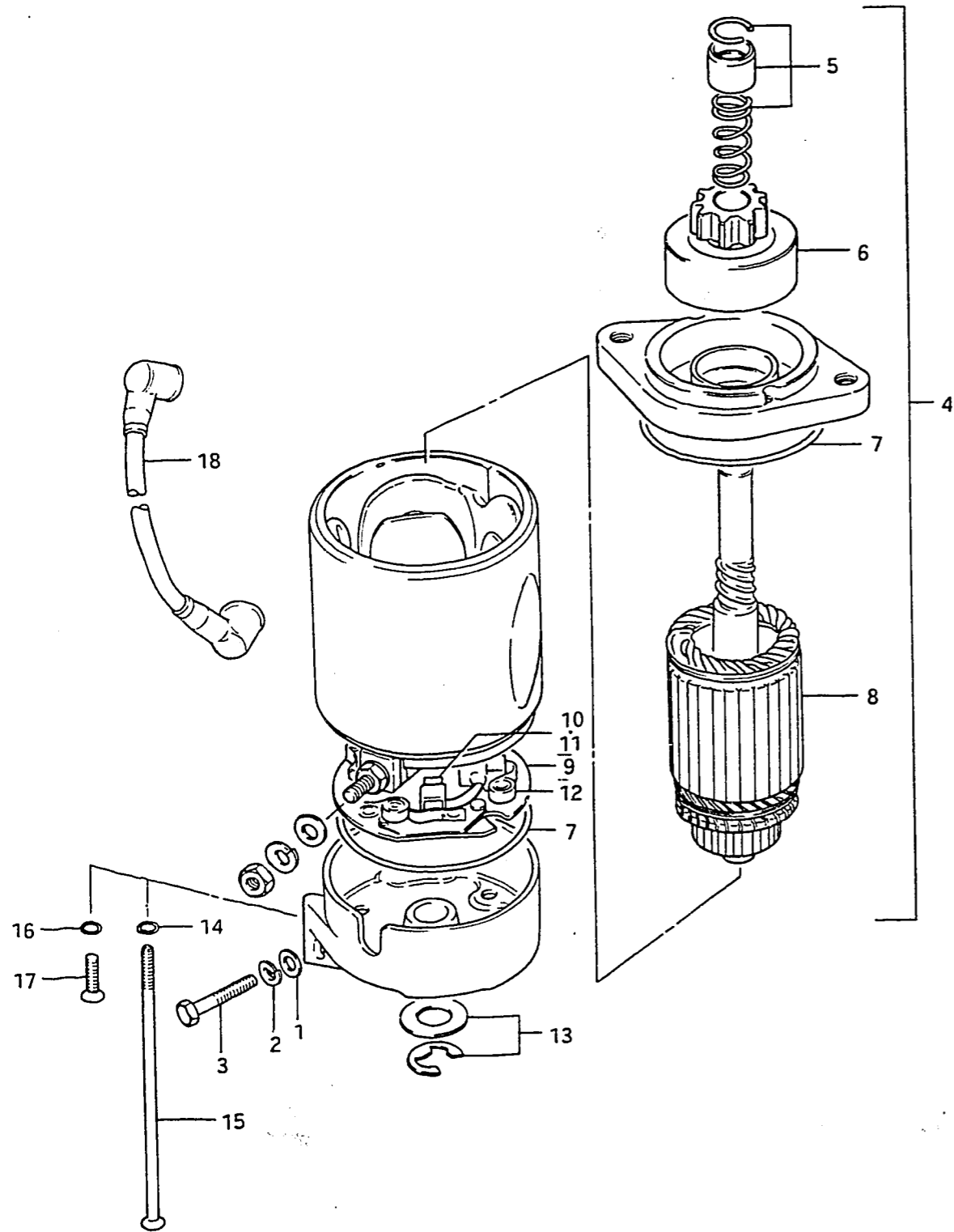

Q'TY

REMARKS

REF.NO.	PART NO.	DESCRIPTION	Q'TY	REMARKS
1	08322-11088	WASHER	1	
2	08321-21088	LOCK WASHER	1	
3	01107-08258	BOLT	1	
4	31100-95300	MOTOR ASSY, starting	1	
5	31312-95520	.STOPPER SET, pinion	1	
6	31320-94510	.PINION ASSY	1	
7	31264-95520	.O RING	2	
8	31310-95521	.ARMATURE	1	
9	31173-95521	.HOLDER ASSY, motor brush	1	
10	31131-95520	..BRUSH (+)	2	
11	31132-95520	..BRUSH (-)	2	
12	31135-95240	..SPRING, brush	4	
13	31360-95520	.WASHER KIT	1	
14	31283-95520	.O RING	2	
15	31281-95520	.BOLT	2	
16	31284-95520	.O RING	2	
17	31282-95520	.SCREW	2	
18	33820-95301	CABLE, (+) terminal relay	1	L:180

FIG. 12

Q'TY

REMARKS

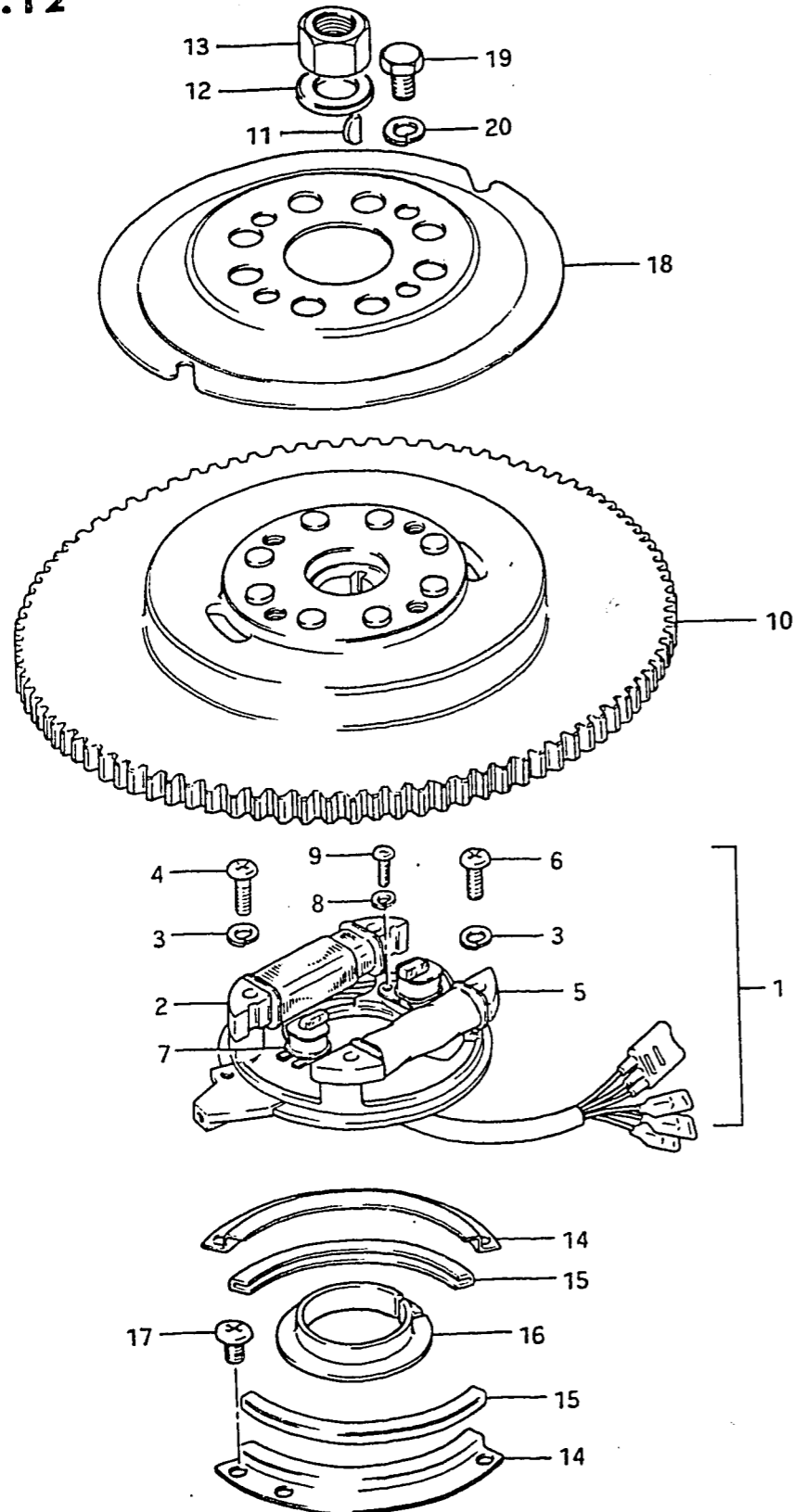

REF.NO.	PART NO.	DESCRIPTION	Q'TY	REMARKS
1	32101-95310	STATOR ASSY	1	
2	32120-95301	.COIL, battery charging	1	
3	08321-21058	.LOCK WASHER	4	
4	02112-05258	.SCREW	2	
5	32140-95301	.COIL, ignition primary	1	
6	02112-05208	.SCREW	2	
7	32150-95302	.SENSOR, ignition timing	2	
8	08321-21058	.LOCK WASHER	4	
9	02112-05108	.SCREW	4	
10	32102-95304	ROTOR	1	
11	08341-31059	KEY	1	
12	09180-18007	WASHER	1	
13	08310-12188	NUT	1	
14	32399-95300	RETAINER (3)	2	
15	32396-95302	RETAINER (2)	2	
16	32395-95310	RETAINER (1)	1	
17	02112-06088	SCREW	4	
18	32725-95310	INSULATOR, magneto	1	
19	01107-08168	BOLT	4	
20	08321-21068	LOCK WASHER	4	

FIG.13

FIG.13 (C- 6) IGNITION

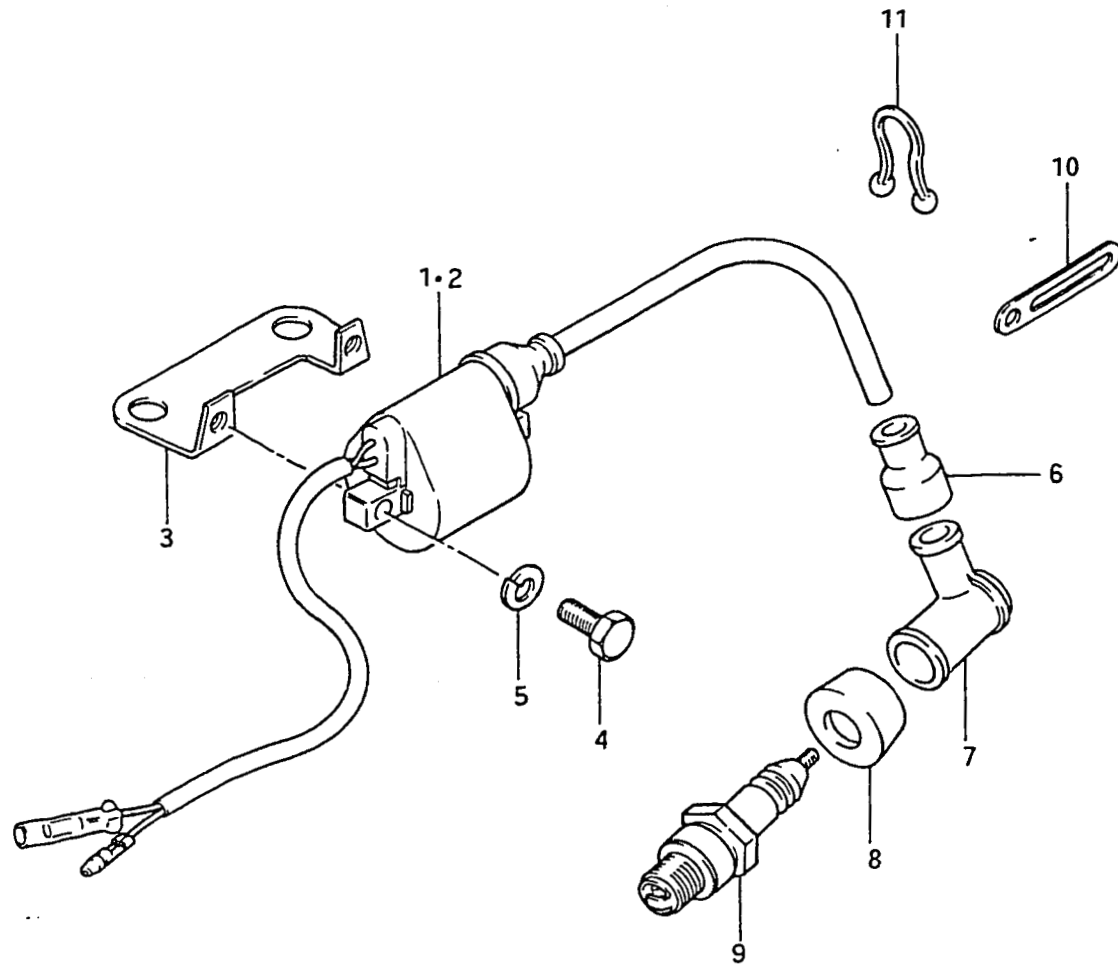

REF.NO.	PART NO.	DESCRIPTION	Q'TY	REMARKS
1	33410-95301	COIL ASSY, ignition upper	1	
2	33420-95301	COIL ASSY, ignition lower	1	
3	33445-95301-02M	STAY, ignition coil	2	
4	01107-06168	BOLT	4	
5	08321-21068	LOCK WASHER	4	
6	33542-98000	SEAL, high tension cord	2	
7	33510-22010	CAP, spark plug	2	
8	33541-93310	SEAL, spark plug	2	
9	09482-00198	SPARK PLUG (B8HS 1.0)	2	
10	09404-06412	CLAMP, ignition coil	1	
11	09408-00012	CLAMP	1	

FIG. 14

FIG.14 (C- 7) ELECTRICAL (1)

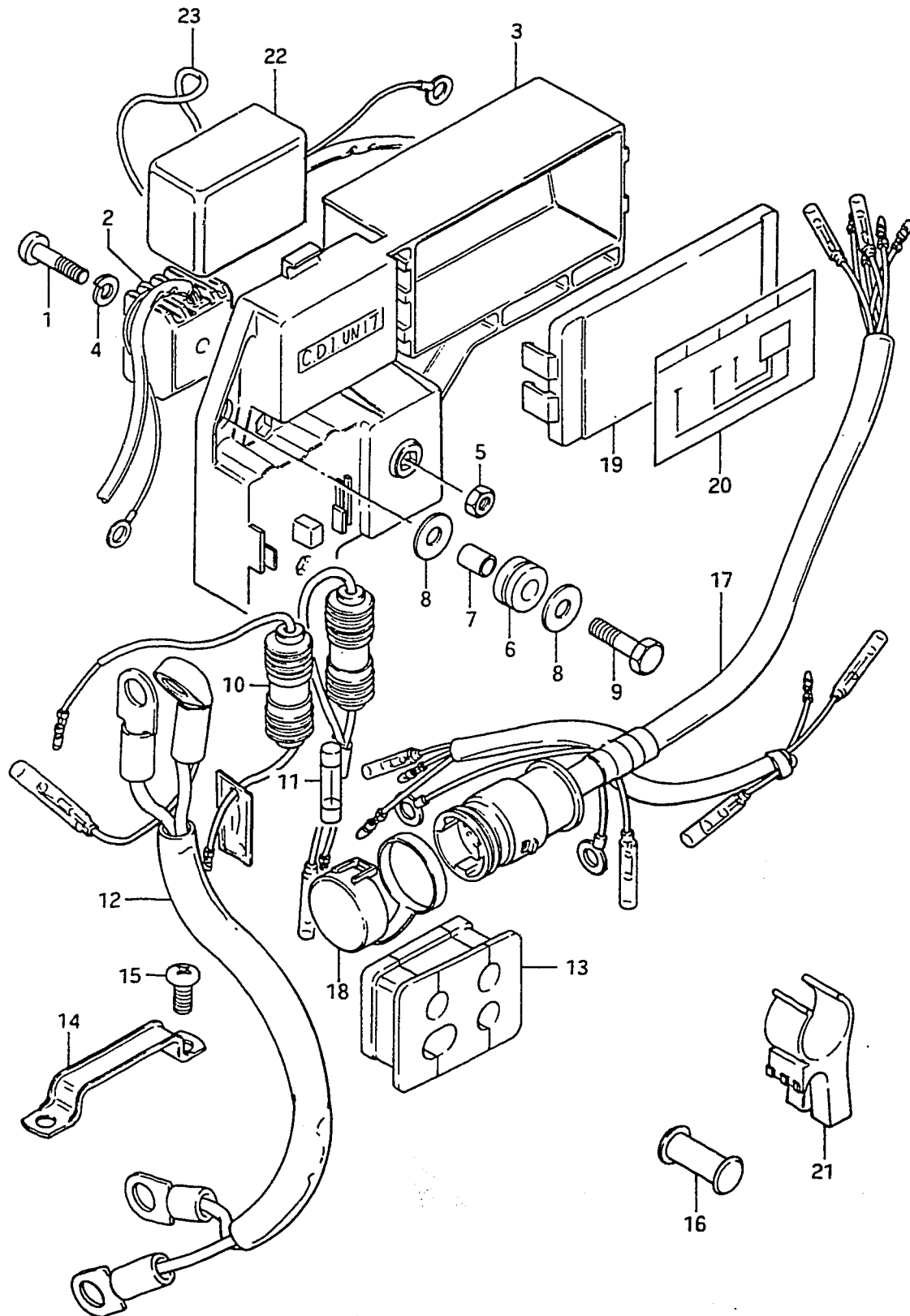

REF.NO.	PART NO.	DESCRIPTION	Q'TY	REMARKS
1	02112-05258	SCREW	1	
2	32800-95720	RECTIFIER ASSY	1	
3	32890-95300	HOLDER, electric parts	1	
4	08321-21058	LOCK WASHER	1	
5	08310-11058	NUT	1	
6	09320-08001	CUSHION	3	
7	09180-06044	SPACER (6.1x8x12)	3	
8	09160-06052	WASHER	3	
9	01107-06258	BOLT	3	
10-1	36740-94500	CASE ASSY, fuse	1	
10-2	36740-95252	CASE ASSY, fuse	1	
11	09481-20001	.FUSE (20A)	1	
12	33810-95300	CABLE ASSY, starting motor	1	
13	36656-95501	GROMMET, wiring harness	1	
14	36659-95500	CLAMP, wiring harness L:86	1	
15	09125-06021	SCREW	2	
16	36661-95210	CAP, grommet	2	
17	36610-95311	WIRING HARNESS, remote control	1	
18	36631-94300	.CAP	1	
19	36650-95300	COVER, joint box	1	
20	36652-95300	LABEL, joint diaphragm	1	
21	36616-95300	HOLDER, connector	1	
22	32900-95301	C.D.I UNIT	1	
23	09280-52001	BAND	1	

FIG. 15

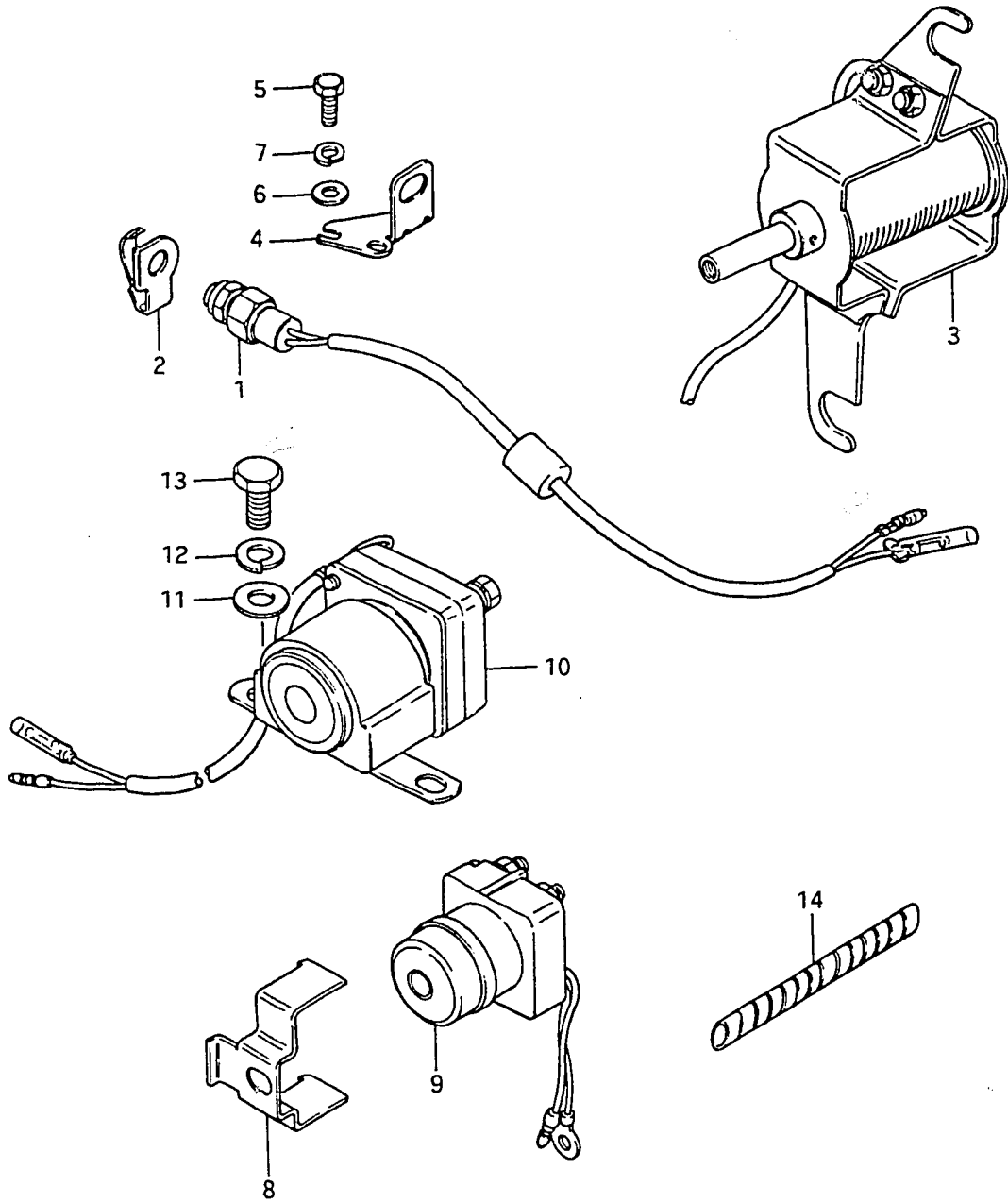

FIG.15 (C- 8) ELECTRICAL (2)

Q'TY

REMARKS

REF.NO.	PART NO.	DESCRIPTION	Q'TY	REMARKS
1	37721-95252	SWITCH ASSY, neutral	1	
2	37725-94301	ACTUATOR, neutral switch	1	
3	38600-95252	SOLENOID ASSY, choke	1	
4	37726-95301	BRACKET, neutral switch	1	
5	09100-06020	.BOLT	2	
6	09160-06015	.WASHER	2	
7	09162-06001	.LOCK WASHER	2	
8	31805-96350	BRACKET, motor relay	1	
9	31800-95502	RELAY, starting motor	1	
10	38410-95510	TRIM RELAY, up in	2	
11	09160-06015	WASHER	4	
12	09162-06001	LOCK WASHER	4	
13	09100-06019	BOLT	4	
14	34863-94500	TUBE	1	L:50

FIG.16

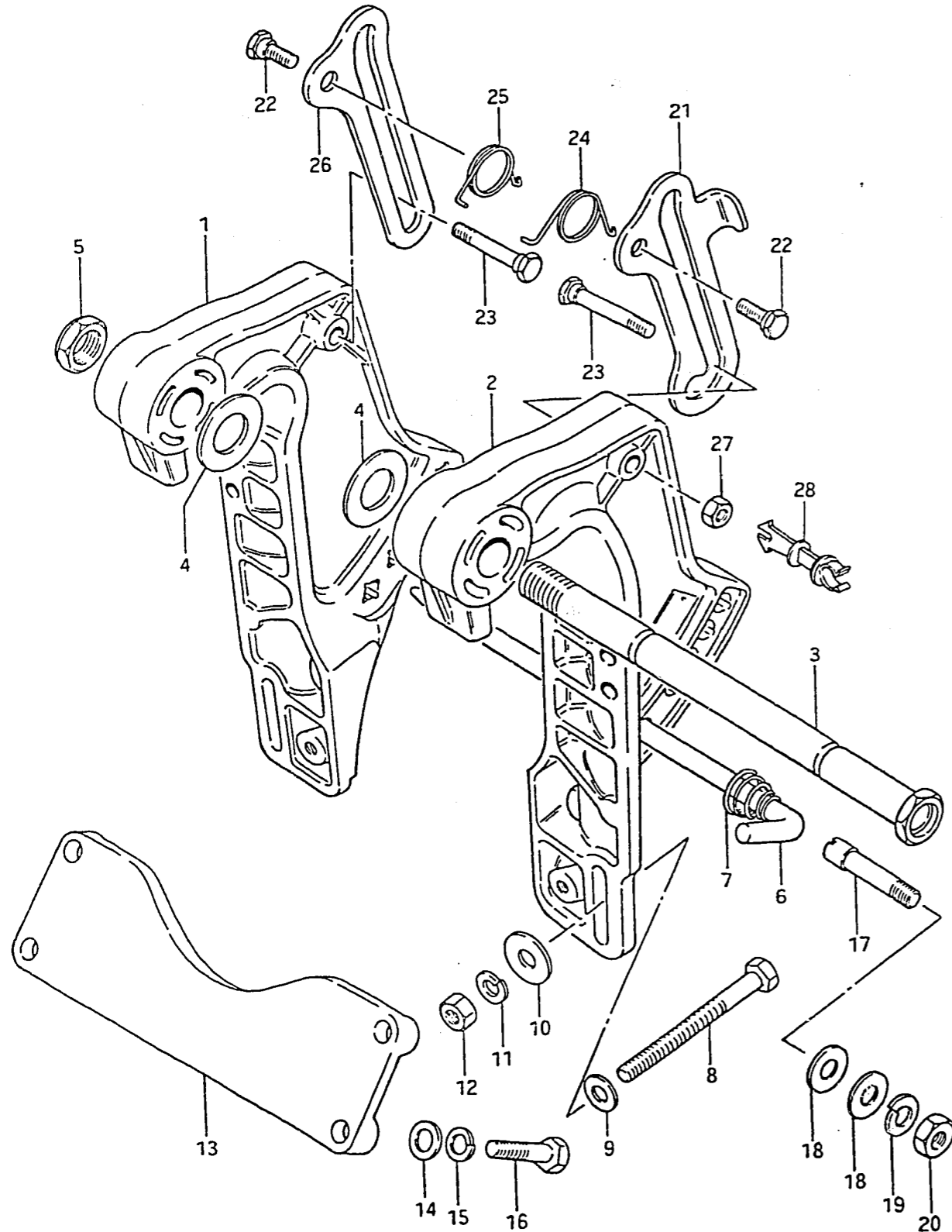

Q'TY

REMARKS

REF.NO.	PART NO.	DESCRIPTION	Q'TY	REMARKS
1	41111-95203-02M	BRACKET, clamp RH	1	
2	41121-95230-02M	BRACKET, clamp LH	1	
3	41130-95500	SHAFT, clamp bracket	1	
4	09161-22001	WASHER	2	
5	09159-22002	NUT	1	
6	45421-95201	PIN	1	
7	09441-21002	SPRING, tilt lock pin	1	
8	09100-10175	BOLT, transom (10x100)	4	
9	09160-10040	WASHER (10.5x19x2)	4	
10	09160-10050	WASHER (10.5x30.3x2)	4	
11	09162-10002	LOCK WASHER	4	
12	09140-10015	NUT	4	
13	41311-95300-02M	PLATE, clamp bracket	1	
14	09160-10040	WASHER	4	
15	09162-10002	LOCK WASHER	4	
16	09100-10123	BOLT	4	
17	48211-95510	PIN	2	
18	09160-12038	WASHER	4	
19	09162-12002	LOCK WASHER	2	
20	09140-12020	NUT	2	
21	41222-95201-02M	ARM, tilt lock	1	
22	09111-12006	BOLT, tilt lock arm	2	
23	09111-10015	BOLT, tilt lock arm clamp	2	
24	09448-27006	SPRING, tilt lock arm	1	
25	09448-27007	SPRING, tilt stop arm	1	
26	41223-95202-02M	ARM, tilt stop	1	
27	09140-10015	NUT	2	
28	33835-95500	CLAMP, PTT motor cable	1	

FIG.17

FIG.17 (C-10) SWIVEL BRACKET

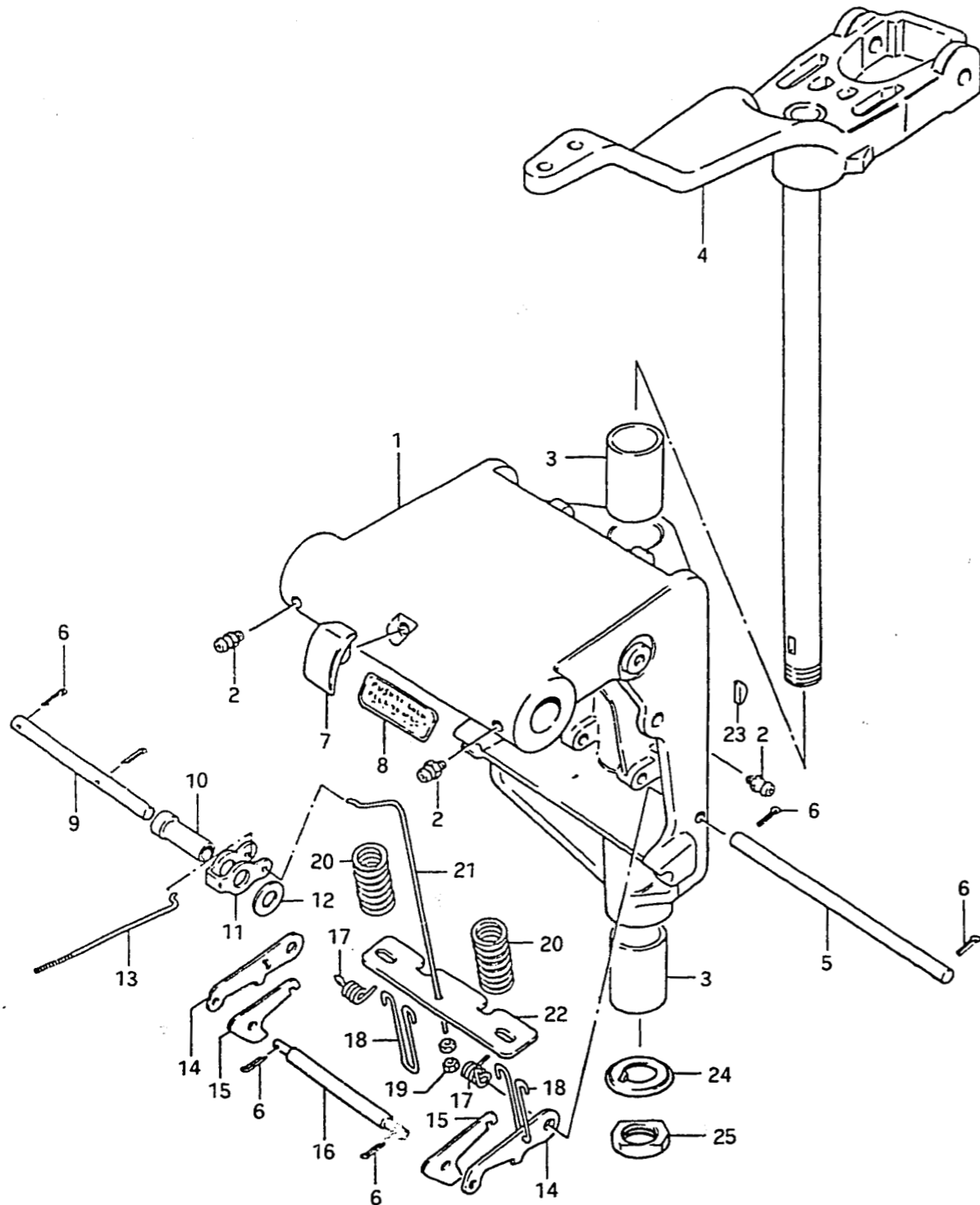

REF.NO.	PART NO.	DESCRIPTION	Q'TY	REMARKS
1	43111-95205-02M	BRACKET, swivel	1	
2	22511-99000	GREASE NIPPLE	3	
3	09306-26005	BUSHING, steering	2	
4	43750-95221-02M	BRACKET, steering	1	
5	45245-95201	SHAFT, reverse lock arm	1	
6	09204-01001	COTTER PIN	6	
7	45261-95201	KNOB, release	1	
8	43241-95202	MARK, release knob	1	
9	45254-95201	SHAFT, release arm (8x73)	1	
10	09180-08082	SPACER	1	
11	45253-95201	ARM, release	1	
12	09160-08015	WASHER (8.5x16x1.2)	1	
13	45251-95200	ROD, release	1	
14	45241-95201	LINK, reverse lock arm	2	
15	45231-95200	ARM, reverse lock	2	
16	45243-95201	PIN, reverse lock arm	1	
17	09444-12001	SPRING, lock arm shaft	2	
18	45244-95200	STOPPER, reverse lock arm	2	
19	09140-03002	NUT	2	
20	09440-21005	SPRING, reverse lock arm	2	
21	45252-95200	LINK, release lever	1	
22	45242-95202	PLATE, reverse lock arm	1	
23	09420-05003	KEY, pilot shaft	1	
24	09166-25004	WASHER, pilot shaft	1	
25	09140-24008	NUT, pilot shaft	1	

FIG.18 (D- 2) ENGINE HOLDER

FIG.18

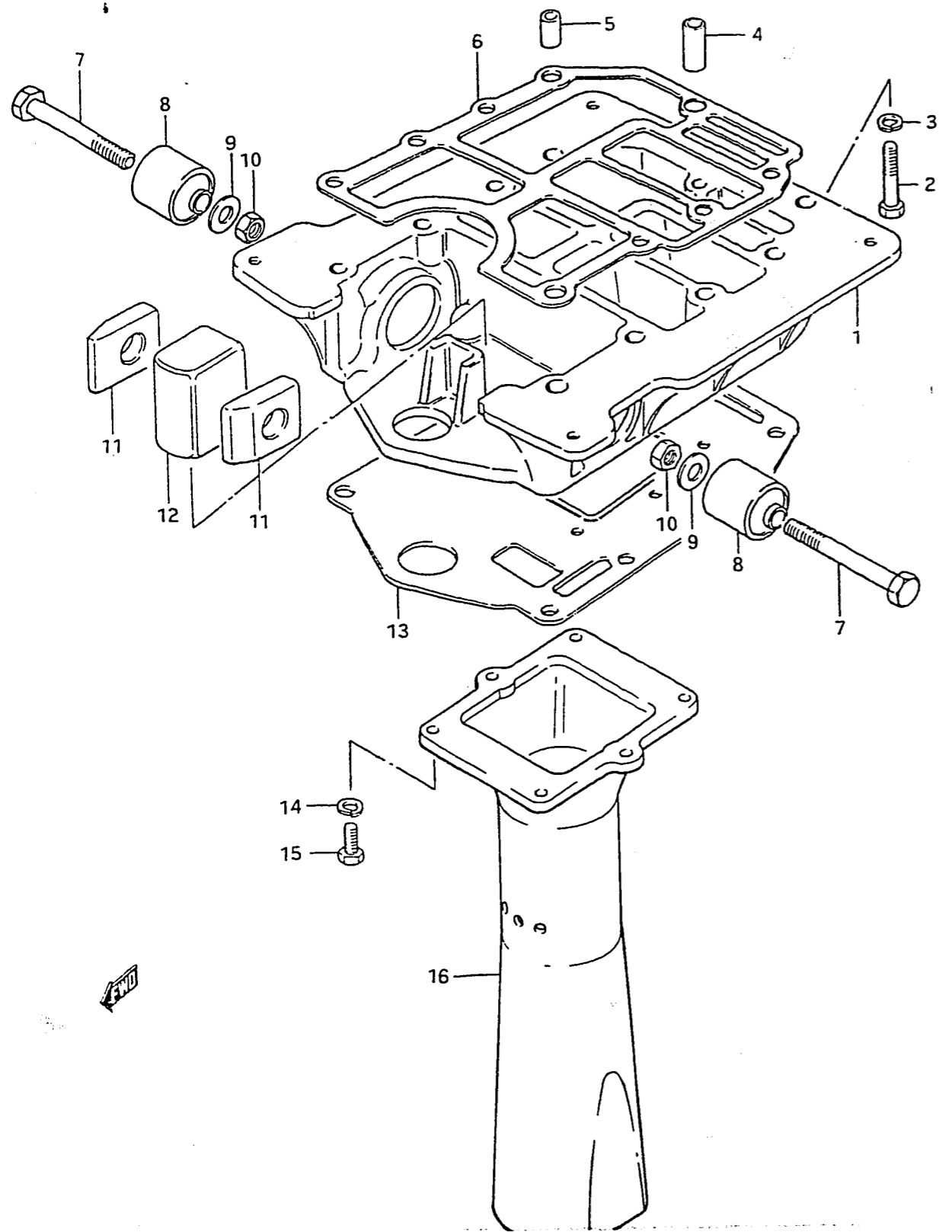

Q'TY

REMARKS

REF.NO.	PART NO.	DESCRIPTION	Q'TY	REMARKS
1	51111-95203-02M	HOLDER, engine	1	
2	09100-08163	BOLT (8x35)	2	
3	09162-08003	LOCK WASHER	2	
4	09206-11005	COLLAR, holder (8.4x11x20)	1	
5	09205-11001	DOWEL PIN (11x14)	2	
6	51211-95203	GASKET, engine holder	1	
7	09100-10204	BOLT, upper mounting (10x70)	2	
8	54130-95201	MOUNTING, upper	2	
9	09160-10040	WASHER (10.5x19x2)	2	
10	09140-10015	NUT	2	
11	54136-95200	STOPPER, upper mounting	2	
12	54135-95200	MOUNTING, upper thrust	1	
13	52113-95300	GASKET, driveshaft housing	1	
14	09162-06001	LOCK WASHER	6	
15	09100-06020	BOLT, exhaust tube (6x20)	6	
16	14211-95341	TUBE, exhaust	1	

D2

FIG.19 (D- 3) DRIVESHAFT HOUSING

FIG.19

REF.NO.	PART NO.	DESCRIPTION	Q'TY	REMARKS
1	52111-95220-02M	HOUSING, driveshaft	1	
2	09100-08213	BOLT (8x55)	8	
3	09162-08003	LOCK WASHER	8	
4	09160-08015	WASHER (8.5x16x1.2)	8	
5	09205-11001	DOWEL PIN	2	
6	54160-95500	MOUNTING, lower	1	
7	09387-46001	CLIP, mounting set	2	
8	54167-95500	MOUNT, lower side	2	
9	09250-28001	CAP, lower mounting bracket	2	
10	09140-12020	NUT, lower mounting	1	
11	09160-12033	WASHER (12.5x22x2.5)	2	
12	09100-12019	BOLT, lower mounting (12x145)	1	
13	09160-25025	WASHER, pilot shaft (25x48x2)	1	
14	54210-95201-02M	BRACKET, lower mounting	1	
15	54165-95200	MOUNTING, lower thrust	1	

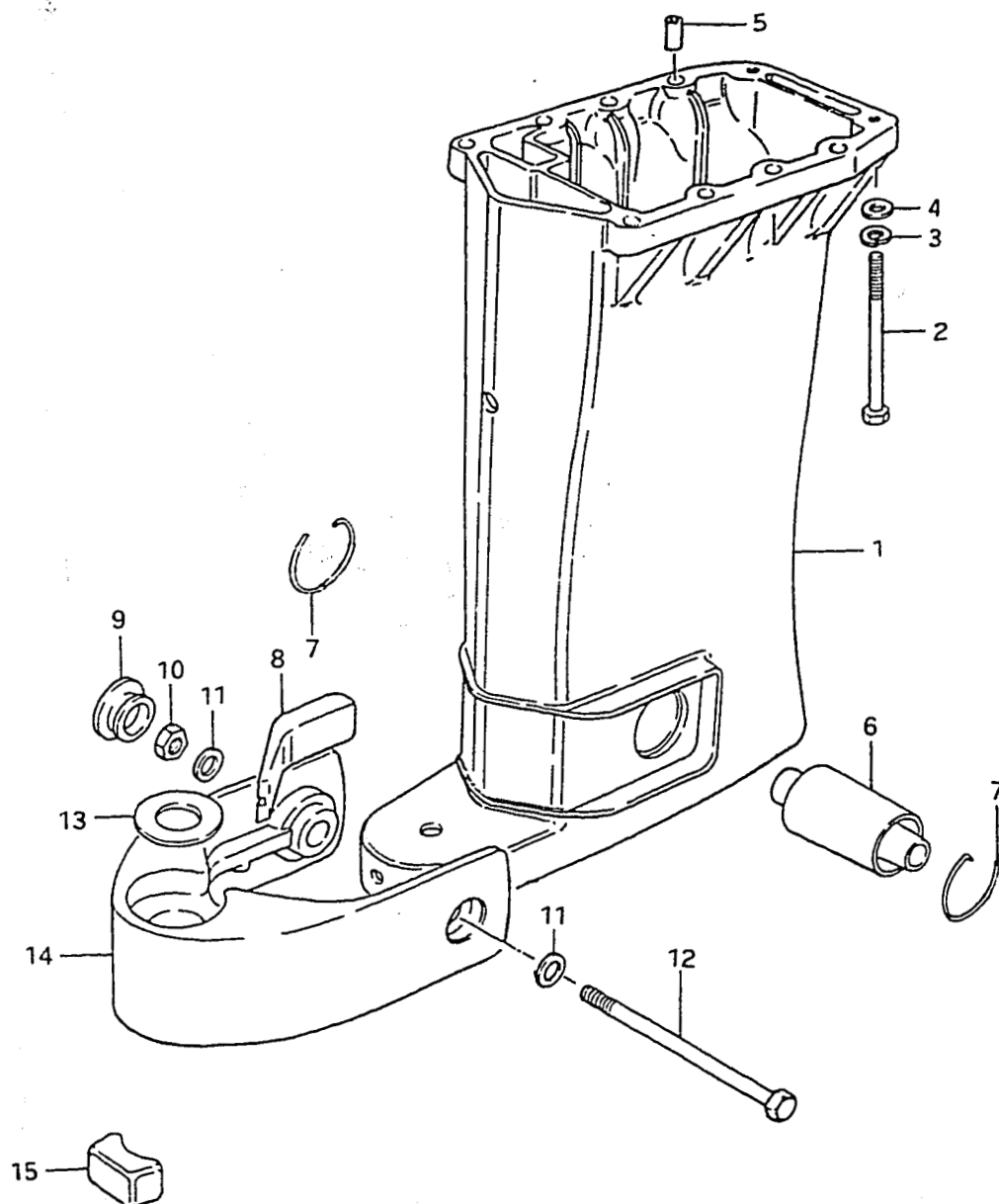
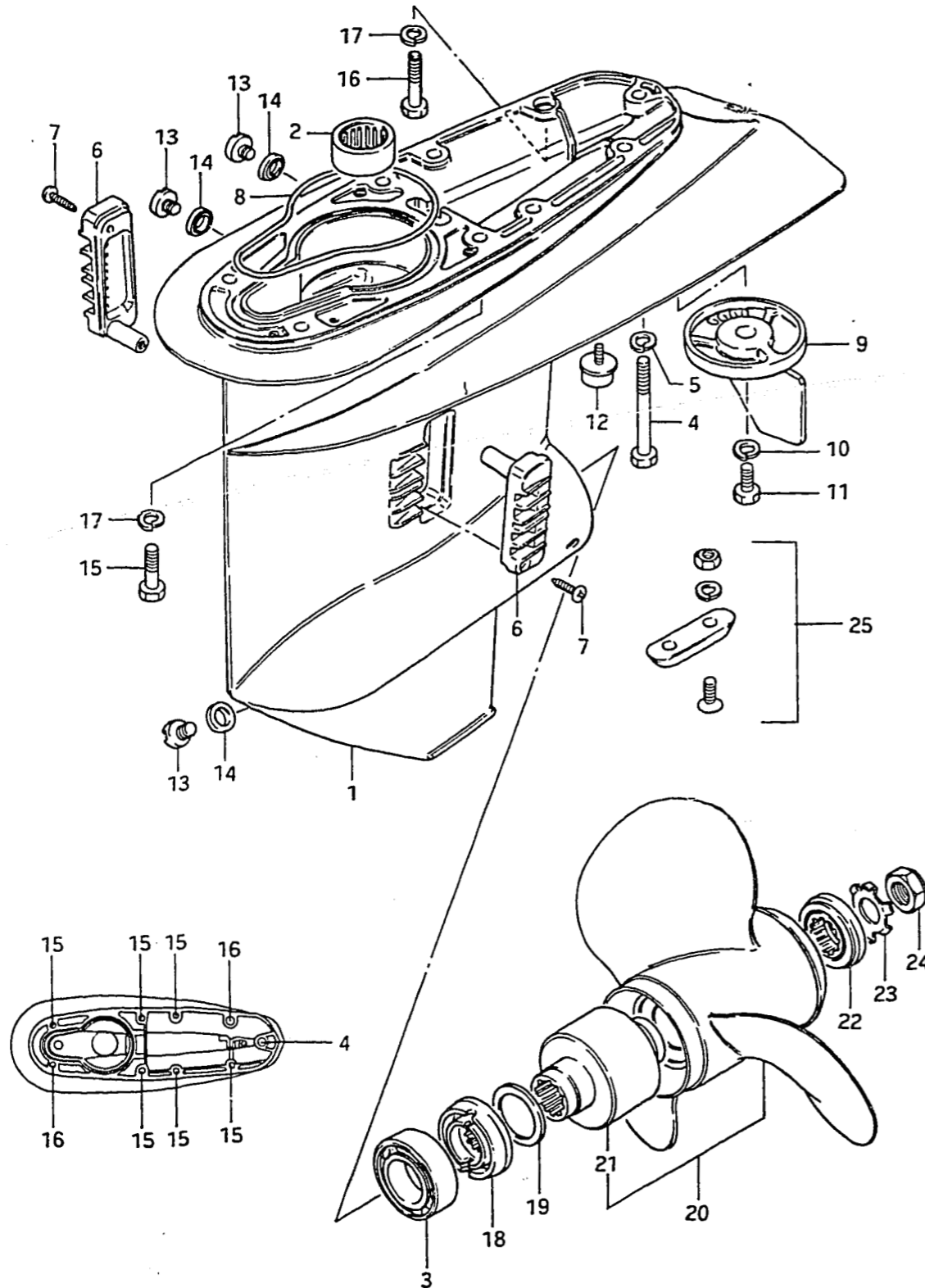
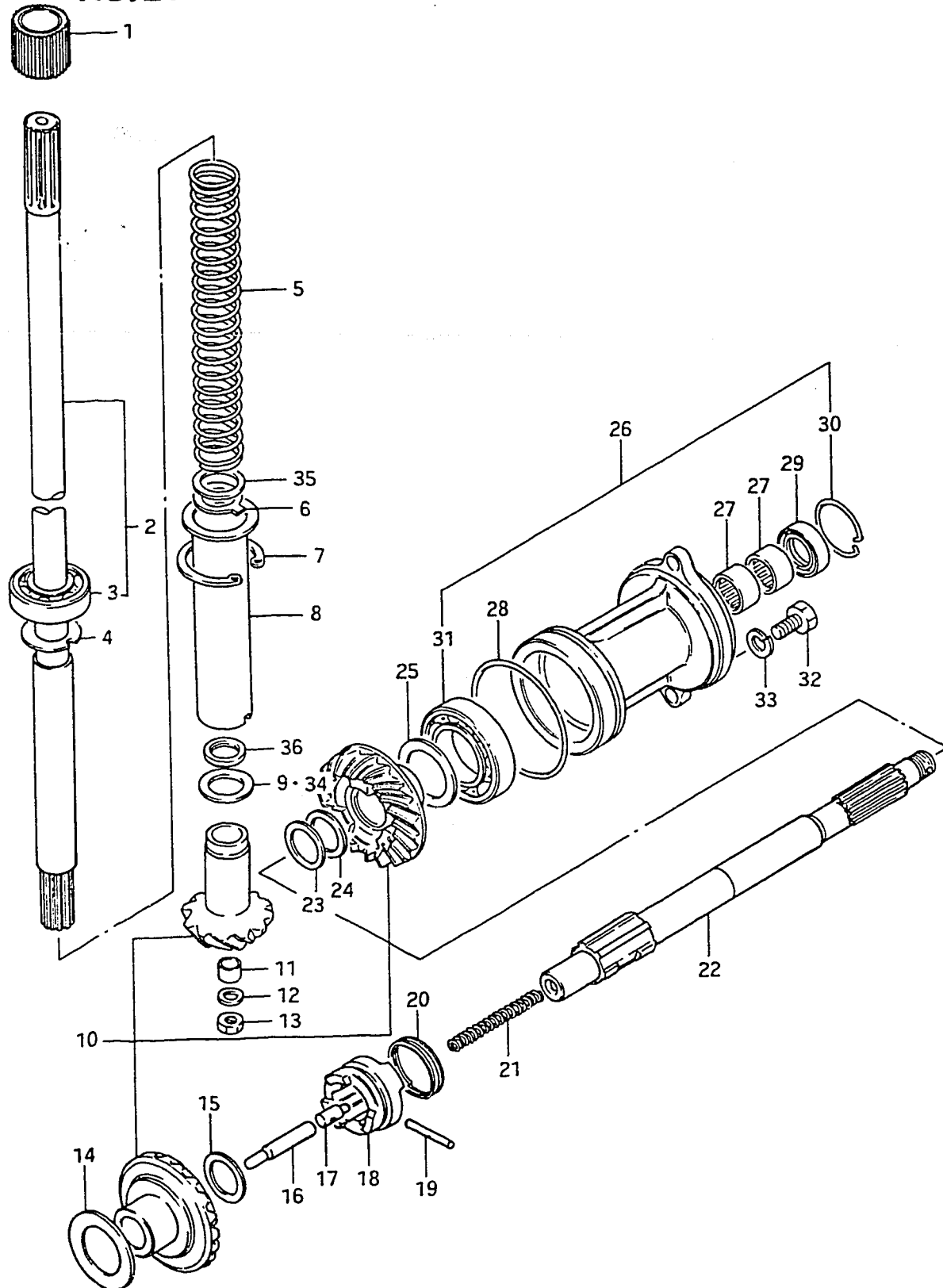

FIG. 20



REF.NO.	PART NO.	DESCRIPTION	Q'TY	REMARKS
1	55100-95303-02M	CASE SET, gear	1	
2	09263-26008	.BEARING, pinion.	1	
3	09263-30004	.BEARING, propeller shaft	1	
4	09100-10159	BOLT, gear case	1	
5	09162-10002	LOCK WASHER	1	
6	17631-95201	FILTER, water	2	
7	03142-04209	SCREW	2	
8	55122-95201	SEAL, gear case	1	
9	55125-95300-02M	TRIM TAB	1	
10	09162-08003	LOCK WASHER	1	
11	09100-08215	BOLT, trim tab (8x16)	1	
12	55320-93142	ZINC, protection	1	
13	09248-10004	PLUG, drain	3	
14	09168-10022	GASKET, drain plug	3	
15	09100-08216	BOLT	6	
16	09100-08214	BOLT	2	
17	09162-08003	LOCK WASHER	8	
18	57632-95304	STOPPER, propeller bushing	1	
19	09160-32006	WASHER (32.6x45x1)	0-1	
20-1	58100-95210-01T	PROPELLER (3x11-1/2x10)	1	S1000
20-2	58100-95220-01T	PROPELLER (3x11-1/2x11)	1	S1100
20-3	58100-95391-01T	PROPELLER (3x11-5/8x12)	1	S1200
20-4	58100-94311-01T	PROPELLER (3x11-1/2x13)	1	S1301
20-5	58100-95351-01T	PROPELLER (3x11-3/8x14)	1	S1400
20-6	58100-95361-01T	PROPELLER (3x11-1/4x15)	1	S1500,STD
20-7	58100-95371-01T	PROPELLER (3x11-1/8x16)	1	S1600
20-8	58100-95380-01T	PROPELLER (3x11x17)	1	S1700
20-9	58100-94300-01T	PROPELLER (3x11-1/2x9)	1	S900
21	58120-95300	.BUSHING, propeller	1	
22	57633-94300	SPACER, propeller nut	1	
23	57635-95300	WASHER	1	
24	09159-18004	NUT, propeller	1	
25	55300-95500	ZINC, protection	1	OPT

FIG. 21



REF.NO.	PART NO.	DESCRIPTION	Q'TY	REMARKS
1	57130-94301	BUSHING, driveshaft	1	
2	57100-95890	SHAFT SET, drive	1	
3	09265-17001	.BEARING, driveshaft	1	
4	09166-17004	THRUST WASHER	1	
5	09440-26002	SPRING, driveshaft preload	1	
6	09167-20017	LOCK WASHER, driveshaft	1	
7	08331-21479	CIRCLIP	1	
8	57133-95200	COLLAR, preload spring	1	
9-1	09181-17251	SHIM (T:1.0)	0~1	
9-2	09181-17008	SHIM (T:1.1)	0~1	
9-3	09181-17009	SHIM (T:1.2)	0~1	
9-4	09181-17010	SHIM (T:1.3)	0~1	
9-5	09181-17011	SHIM (T:1.4)	0~1	
10	57301-95810	PINION/GEAR SET	1	
11	09180-12087	SPACER (12x16.5x6.5)	1	
12	08211-10162	WASHER	1	
13	09140-10022	NUT	1	
14-1	08221-30455	SHIM (T:0.5)	0~1	
14-2	09181-30007	SHIM (T:0.6)	0~1	
14-3	09181-30008	SHIM (T:0.7)	0~1	
14-4	09181-30009	SHIM (T:0.8)	0~1	
14-5	09181-30010	SHIM (T:0.9)	0~1	
14-6	08211-30451	SHIM (T:1)	0~1	
15	08211-20283	THRUST WASHER (T:2)	1	

FIG.21 (D- 6) TRANSMISSION

FIG. 21

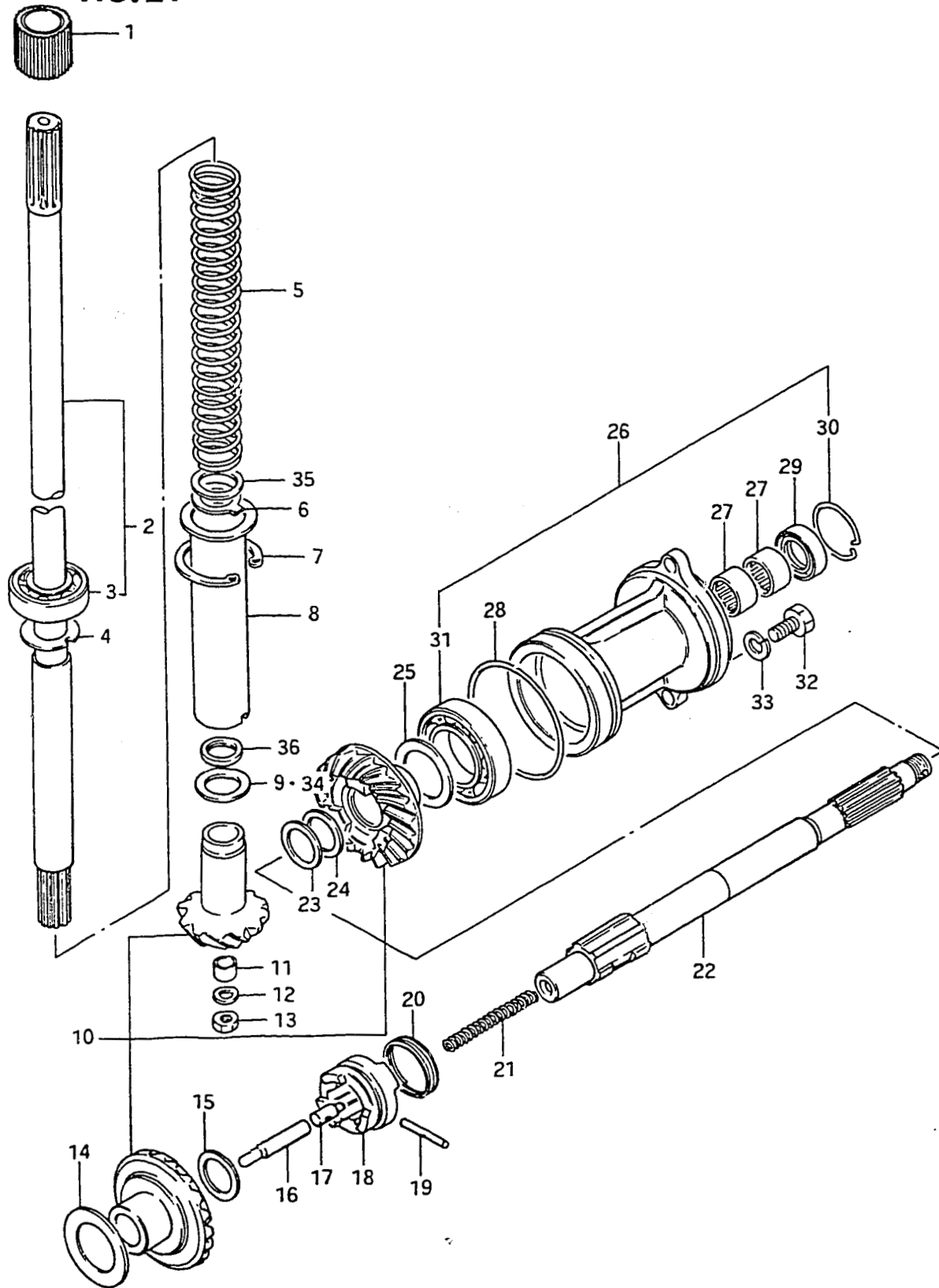

REF.NO.	PART NO.	DESCRIPTION	Q'TY	REMARKS
16	57631-95301	ROD, push	1	
17	09209-09004	PIN, push	1	
18	57621-95206	SHIFTER, clutch dog	1	
19	09202-05022	PIN	1	
20	09440-41002	SPRING, dog	1	
21	09440-08024	SPRING, return	1	
22	57610-95205	SHAFT, propeller	1	
23	09181-22003	SHIM (T:0.5)	0~1	
24-1	09160-22016	THRUST WASHER (T:1.5)	0~1	
24-2	09160-22024	THRUST WASHER (T:1.75)	0~1	
24-3	09160-22025	THRUST WASHER (T:2)	0~1	
25-1	09181-35003	SHIM (T:0.5)	0~1	
25-2	09181-35009	SHIM (T:0.6)	0~1	
25-3	09181-35010	SHIM (T:0.7)	0~1	
25-4	09181-35011	SHIM (T:0.9)	0~1	
25-5	08221-35456	SHIM	0~1	
26	56120-95310-02M	HOUSING, propeller shaft	1	
27	09263-22020	.BEARING, propeller shaft	2	
28	09280-76006	.O RING	1	
29	09289-22007	.OIL SEAL, propeller shaft	1	
30	09387-37001	.RING, propeller shaft oil seal	1	
31	08113-60070	.BEARING, reverse gear	1	
32	09100-08112	BOLT, propeller shaft housing	2	
33	09162-08003	LOCK WASHER	2	
34-1	08211-17252	SHIM, pinion (T:1.5)	1	
34-2	09181-17012	SHIM, pinion (T:1.6)	1	
35	09160-22030	WASHER, spring	1	
36	09160-17029	WASHER, pinion thrust	1	

D6

FIG. 22

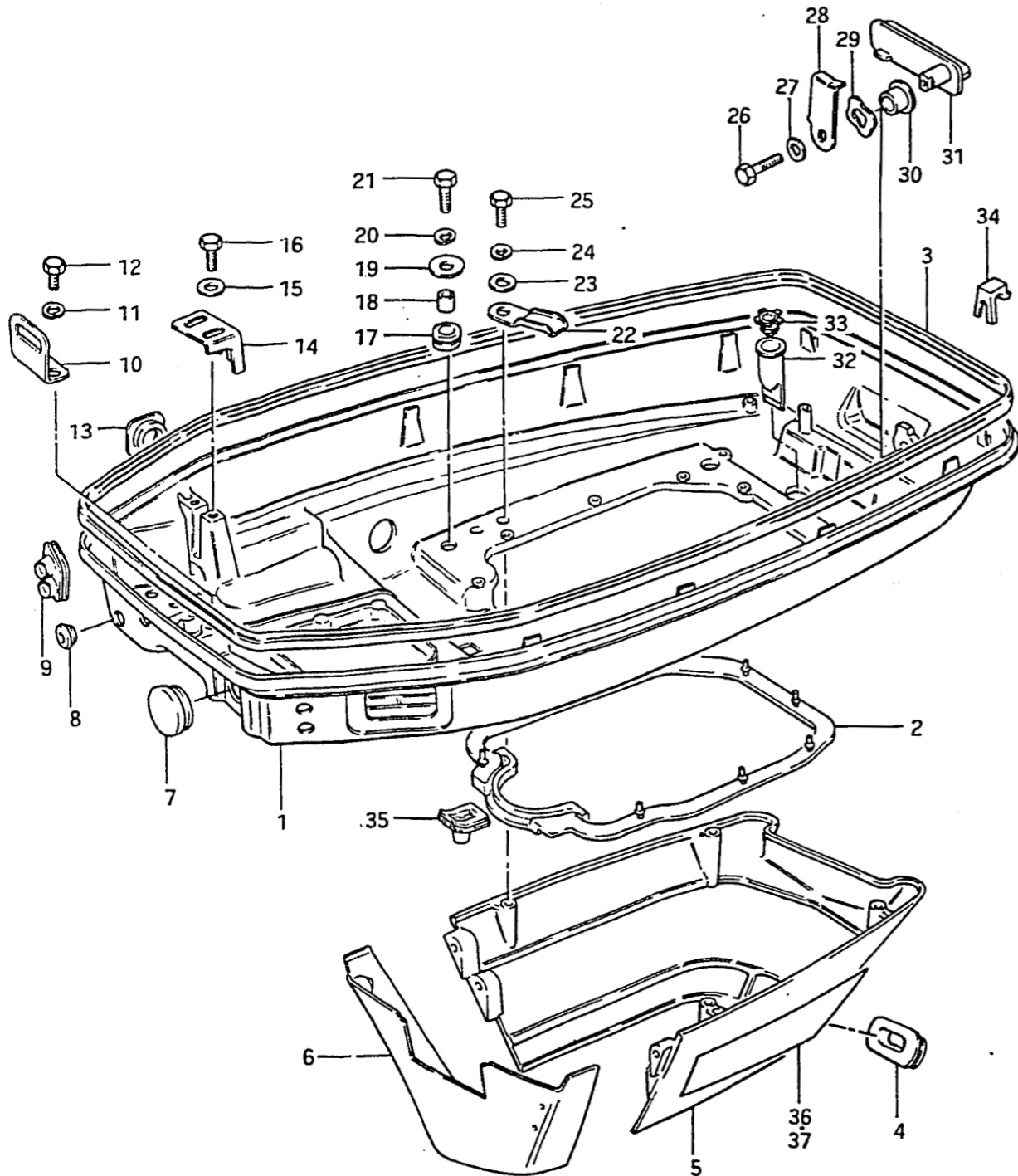

FIG. 22 (D- 7) LOWER COVER

Q'TY:

REF.NO.	PART NO.	DESCRIPTION	REMARKS
1	61110-95300-02M	COVER, lower	1
2	61113-95204	SEAL, lower cover lower	1
3	61112-95207	SEAL, lower cover upper	1
4	61142-95200	GROMMET	1
5	61141-95202-02M	COVER, lower rear	1
6	61131-95201-02M	COVER, lower front	1
7	09250-30003	CAP, starter hole	1
8	63725-95200	GROMMET, choke cable	1
9	67331-95210	GROMMET, control cable	1
10	61116-95202	PLATE, lower cover	1
11	09162-06001	LOCK WASHER	2
12	09100-06058	BOLT (6x15)	2
13	61124-95200	GROMMET	1
14	67271-95211	HOLDER, control cable	1
15	09162-06001	LOCK WASHER	2
16	09100-06058	BOLT (6x15)	2
17	09320-10011	CUSHION, lower cover	4
18	09180-06112	SPACER (6.8x10x11.5)	4
19	09160-06047	WASHER (6.5x22x2)	4
20	09162-06001	LOCK WASHER	4
21	09100-06089	BOLT (6x25)	4

FIG. 22

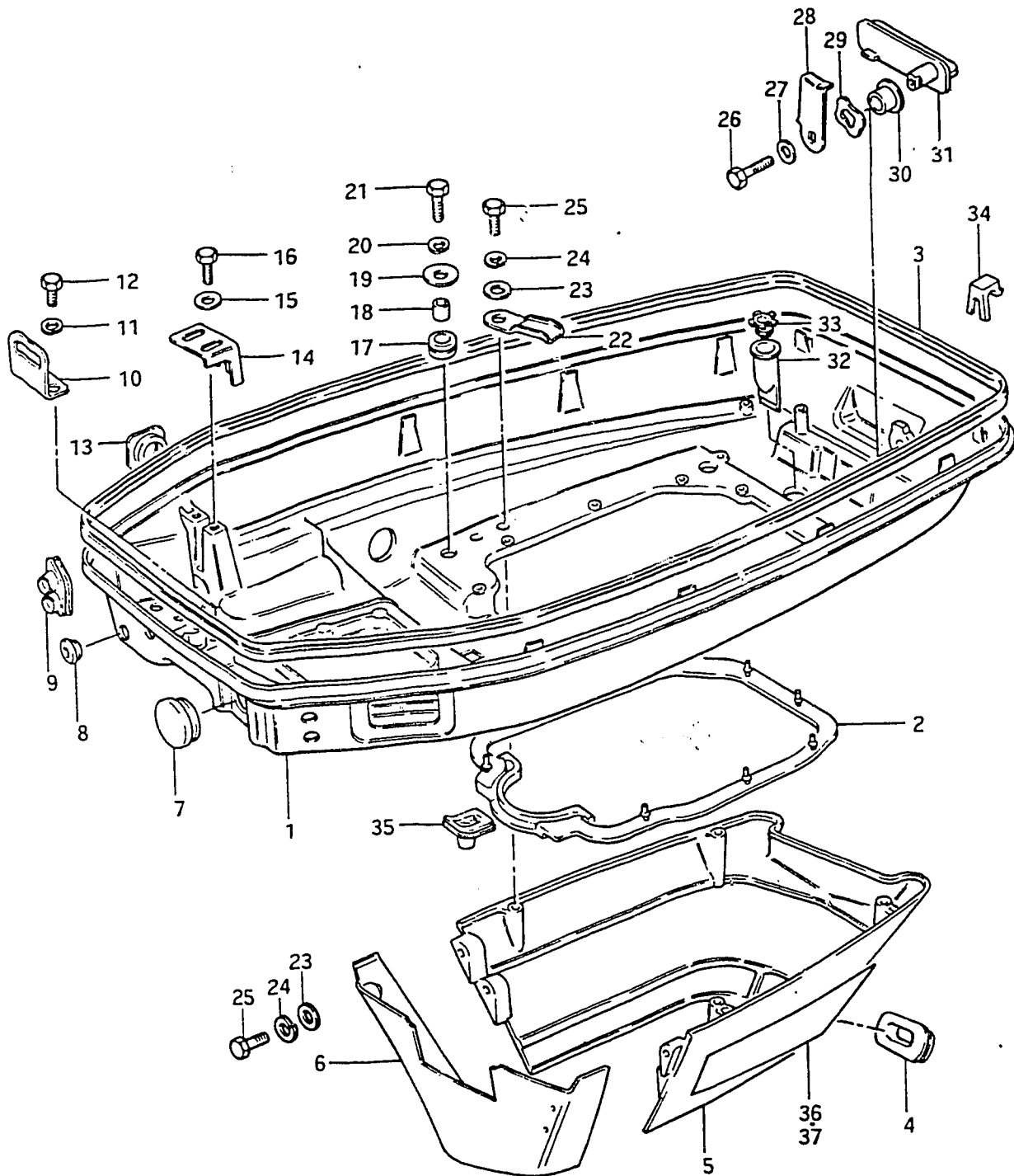

FIG. 22 (D- 8) LOWER COVER

Q'TY

REMARKS

REF.NO.	PART NO.	DESCRIPTION	Q'TY	REMARKS
22	09403-07309	CLAMP, fuel hose	1	
23	09160-06015	WASHER (6.5x13x1)	8	
24	09162-06001	LOCK WASHER	8	
25	09100-06020	BOLT (6x20)	8	
26	01107-06108	BOLT (6x25)	1	
27	08322-21068	WASHER	1	
28	61631-95300	HOOK, lower cover	1	
29	09164-13005	WAVE WASHER	1	
30	09306-13002	BUSHING, hook lever	1	
31	61633-95201-02M	LEVER, hook	1	
32	13873-20300	TUBE, drain	1	
33	13979-37400	RETAINER, drain tube	1	
34	36641-95500	STOPPER, relay harness	3	
35	23131-95501	BOOT, clutch rod	1	
36	61221-95560	DECAL, lower cover, R	1	
37	61231-95560	DECAL, lower cover, L	1	

FIG. 23

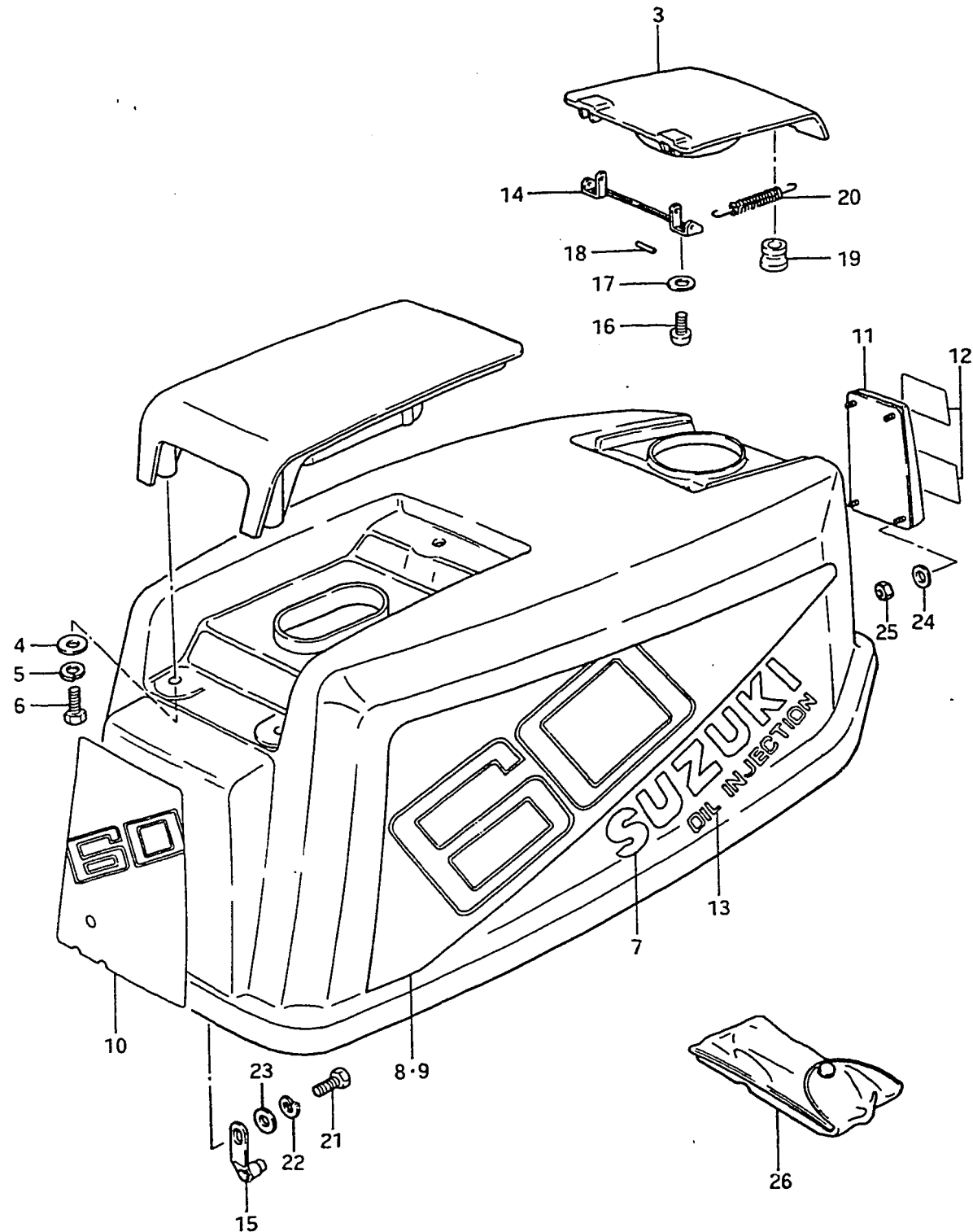

FIG.23 (D- 9) ENGINE COVER

Q'TY

REMARKS

REF.NO.	PART NO.	DESCRIPTION	Q'TY	REMARKS
1	61402-95830-02M	COVER SET, engine	1	
2	61431-95201-02M	.HANDLE, tilt up	1	
3	61481-95300-02M	.LID, oil tank filler	1	
4	09160-06036	.WASHER	3	
5	09162-06001	.LOCK WASHER	3	
6	09100-06019	.BOLT	3	
7	61441-95360	.EMBLEM, side	2	
8	61443-95360	.DECAL, RH "60"	1	
9	61453-95360	.DECAL, LH "60"	1	
10	61435-95360	.EMBLEM, rear "60"	1	
11	61420-95510	.EMBLEM, engine cover front	1	
12	61422-95561	.MARK, front	1	
13	61442-94560	.MARK, oil injection	2	
14	61482-95301	.HINGE, oil tank filler lid	1	
15	61610-96300	.FASTENER	1	
16	09125-06033	.SCREW	2	
17	09160-06055	.WASHER	2	
18	09205-03012	.PIN	2	
19	09329-05007	.CUSHION	2	
20	09443-04003	.SPRING	2	
21	01107-06128	.BOLT	1	
22	08321-21068	.LOCK WASHER	1	
23	08322-21068	.WASHER	1	
24	09140-05001	.NUT	4	
25	09160-05024	.WASHER	4	
26	09800-81800	TOOL ASSY	1	

FIG.24 (D-10) FUEL TANK

FIG. 24

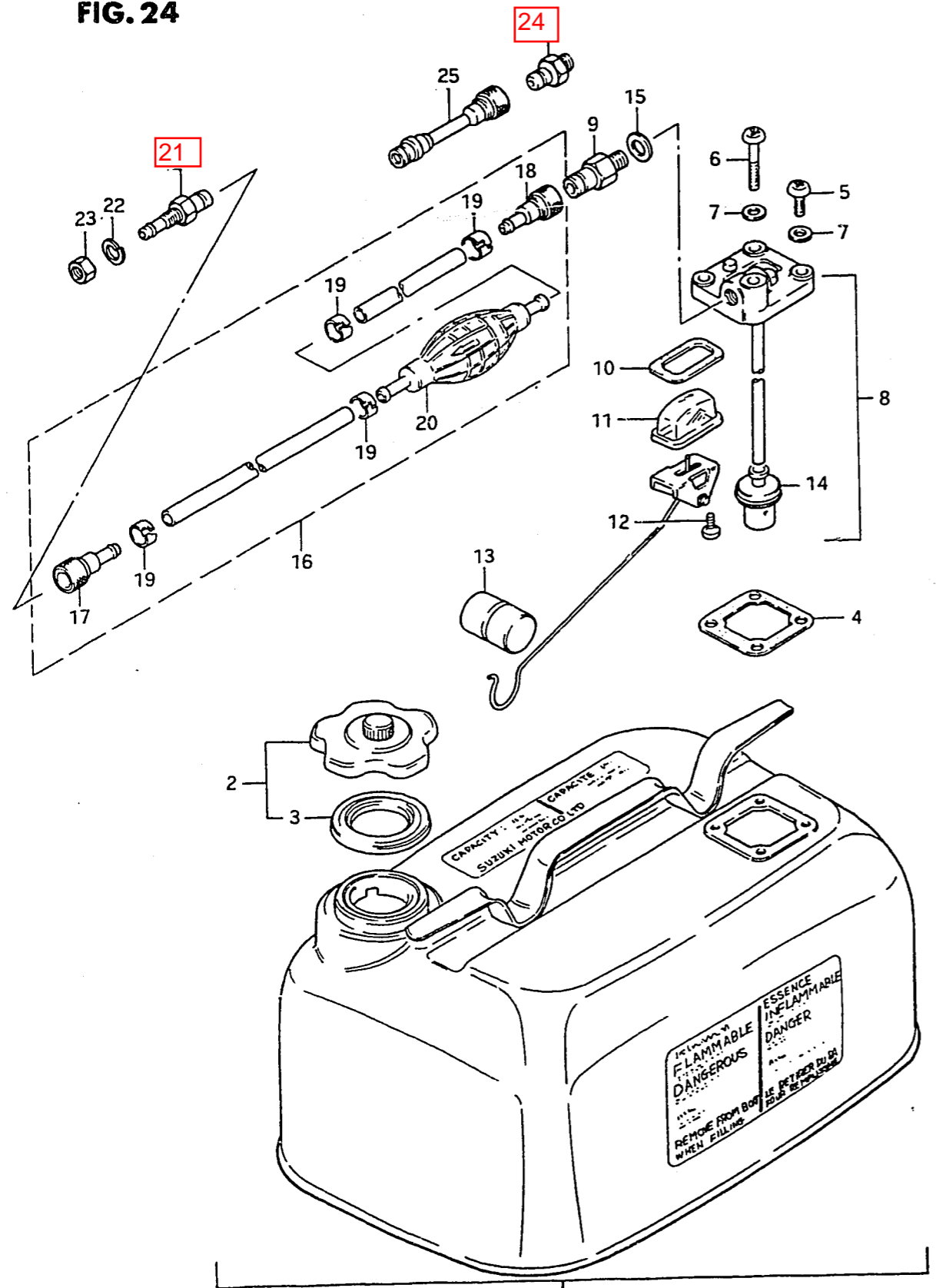

Q'TY

REMARKS

REF.NO.	PART NO.	DESCRIPTION	Q'TY	REMARKS
1	65000-95200	TANK SET, fuel (23L)	1	6 US.GAL./5 IMP.GAL.
2	65510-98507	.CAP ASSY	1	
3	65561-98502	..GASKET	1	
4	65871-93010	.GASKET, fuel gauge	1	
5	02112-06168	.SCREW	3	
6	02112-06408	.SCREW	1	
7	08322-21068	.WASHER	4	
8	65850-95504	.GAUGE ASSY, fuel	1	
9	65740-95500	..PLUG, tank side	1	M12,OD:13
10	65854-93001	..GASKET, strainer	1	
11	65853-93001	..STRANER	1	
12	02112-04108	..SCREW	2	
13	65864-95200	..FLOAT	1	
14	65830-95500	..FILTER, outlet	1	
15	09168-12001	..GASKET (12.5x20x1)	1	
16	65700-95205	HOSE, fuel	1	
17	65750-98505	.SOCKET	1	
18	65750-93000	.SOCKET	1	
19	65781-98500	.CLIP	4	
20	65770-99702	.PUMP, squeeze	1	
21	65720-98520	PLUG, fuel connector	1	
22	08321-21108	LOCK WASHER	1	
23	08310-22108	NUT	1	
24	65720-98590	PLUG, fuel connector	1	OPT,M12-11
25	65700-95271	HOSE, fuel joint	1	OPT

D10

FIG. 25

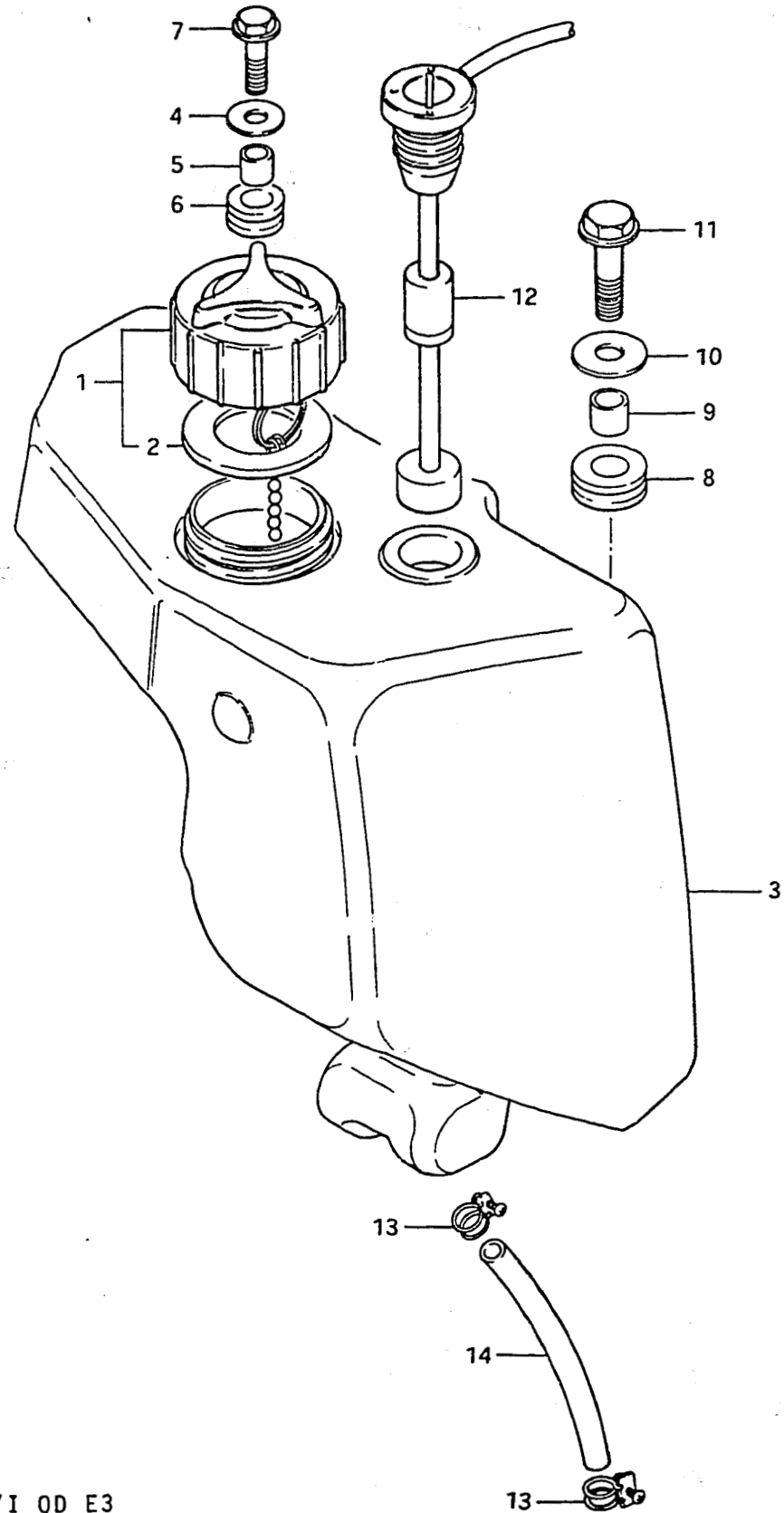
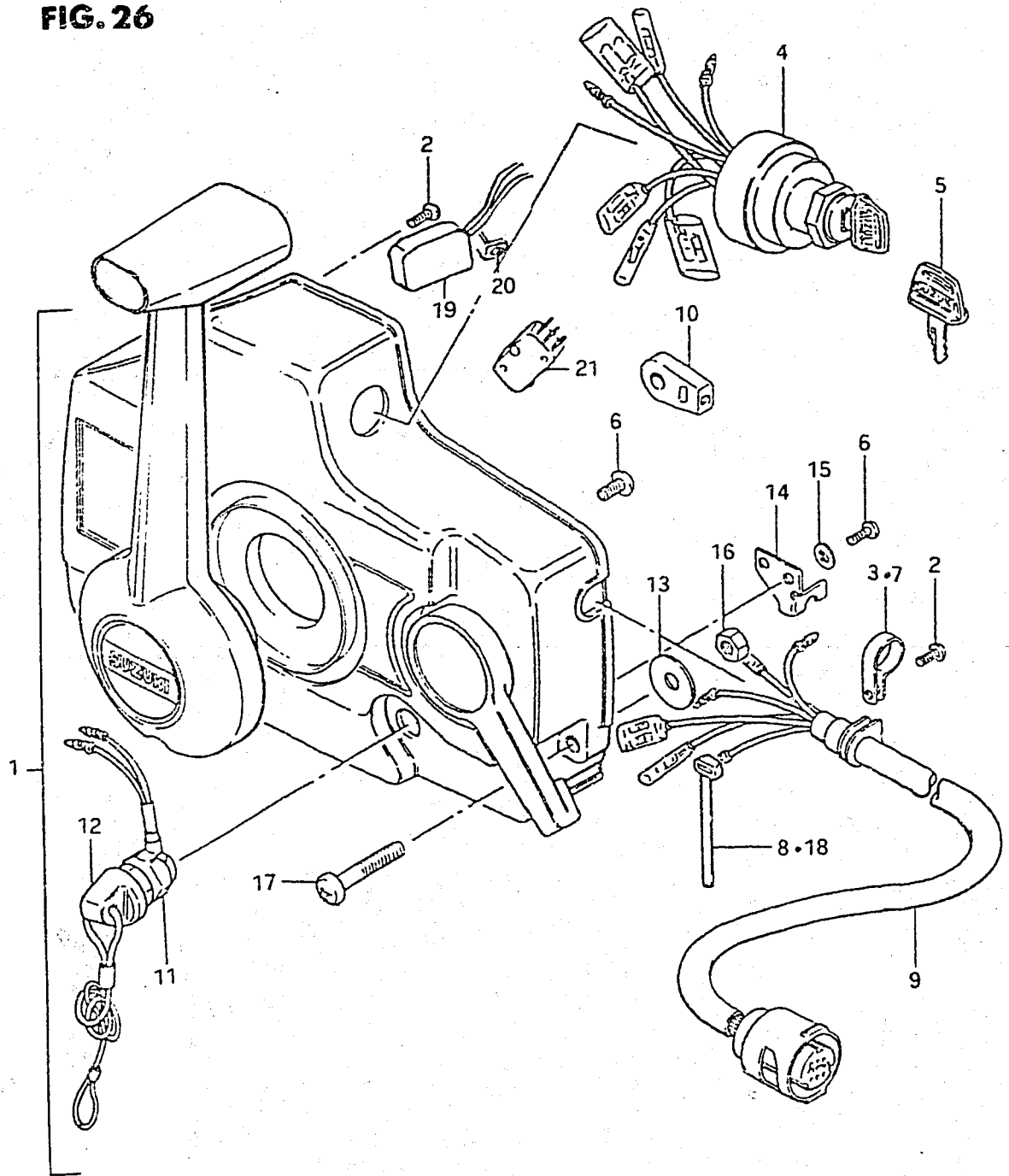

FIG. 25 (D-11) OIL TANK

REF.NO.	PART NO.	DESCRIPTION	Q'TY	REMARKS
1	69200-94502	CAP ASSY, oil tank	1	
2	69241-94500	.GASKET, oil tank	1	
3	69111-95301	TANK, OIL	1	
4	09160-06036	WASHER (6.5x18x1.5)	1	
5	09180-06030	SPACER (6.8x10x10)	1	
6	09320-10008	CUSHION	1	
7	01517-06258	BOLT, lower	1	
8	09320-12027	CUSHION	1	
9	09180-09014	SPACER (9x12x10)	1	
10	09160-08014	WASHER, starting motor	1	8.5x23x1.5
11	01517-08358	BOLT	1	
12	34860-95300	SWITCH ASSY, oil level	1	
13	09401-08402	CLAMP, oil hose	2	
14	09343-04060	HOSE	1	

FIG.26 (D-12) REMOTE CONTROL BOX

FIG. 26



REF.NO.	PART NO.	DESCRIPTION	Q'TY	REMARKS
1	67200-95550	REMOTE CONTROL BOX ASSY	1	
2	67296-94300	.SCREW	4	
3	36622-96300	.CLAMP	1	
4	37110-94301	.SWITCH, ignition	1	
5-1	37141-93300	..KEY, 8511	1	OPT
5-2	37141-93310	..KEY, 8512	1	
5-3	37141-93320	..KEY, 8513	1	
5-4	37141-93330	..KEY, 8611	1	
5-5	37141-93340	..KEY, 8612	1	
5-6	37141-93350	..KEY, 8613	1	
6	67296-94310	.SCREW	6	
7	36622-94300	.CLAMP	1	
8	36632-95501	.BAND	1	
9	36620-94300	.WIRING HARNESS, EXTENTION	1	
10	67275-94300	.CABLE END	2	
11	37820-95254	.SWITCH ASSY, EMERGENCY	1	
12	37823-95251	..CAP / ROPE	1	
13	67288-94300	.WASHER	6	
14	67271-94300	.HOLDER, CABLE	1	
15	67288-94310	.WASHER	3	
16	09140-06004	.NUT	3	
17	09125-06012	.SCREW	3	
18	37119-94300	.BAND	2	
19	38500-95503	.BUZZER	1	
20	38501-95500	.BAND	1	
21	37721-95551	SWITCH, NEUTRAL	1	