



# SUZUKI MARINE

Parts Book

DT 6 (1986-2002)



1703 Hwy 35 So., Laurence Harbor, NJ 08879

**(732) 264-7176**

**(800) 338-0645 FAX (732) 264-2472**

[www.brownspoint.com](http://www.brownspoint.com)

## PREFACE

When it becomes necessary to replace parts on SUZUKI OUTBOARD MOTORS, always use SUZUKI GENUINE PARTS which have passed a strict inspection which guarantees quality and performance.

This parts catalogue covers the list of all service parts for SUZUKI DT6 '86~'02 MODEL.

### INSTRUCTIONS FOR QUOTING THE CATALOGUE

#### 1. DIMENSIONS

Dimensions of the parts in this catalogue are indicated in unit millimeters.

#### 2. ABBREVIATIONS

Abbreviations used in this catalogue are as follows:

AR	: As required	NT	: Number of teeth
ASSY	: Assembly	OPT	: Optional
E.No.	: Engine number	OS	: Over size
F.No.	: Frame number	STD	: Standard
d	: Diameter of material	T	: Thickness
ID	: Inside diameter	US	: Under size
OD	: Outside diameter	W	: Width
L	: Length	W/	: With
LH(PORT)	: Left hand side	S,L,UL,LL	: Transom type
RH(STBD)	: Right hand side	SUS	: Stainless steel
~123456	: Up to F.No.00601-123456	'00	: MODEL:2000
123456~	: From F.No.00601-123456	'01	: MODEL:2001
		'02	: MODEL:2002

12 x 34 x 5.6..... Figures in the description column  
 ↓ ↓ ↓ show the dimensions of parts.  
 ID OD T(or W,L)

→12345-56781 (Parts No.) : indicates that the parts number was changed to 12345-56781 and the new parts are interchangeable with the former ones but the former ones are not interchangeable with new ones.

←12345-56781 (Parts No.) : indicates that the former and new parts are interchangeable with each other and both are usable.

#### 3. INNER PARTS OF ASSEMBLY

Part name with a dot (.) in front as shown in the description column indicates the component of the assembly also available individually.

#### 4. MODIFICATION NOTICE

A parts bulletin will be sent to you on all occasions when changes in parts occur, including interchangeable modifications between new parts and old ones.

#### 5. NOTE

5-1. There are some different parts from those of production models among spare parts for the administrative reasons and common use of them with other models.

5-2. In respect of rubber hoses and vinyl tubes, please be sure to use them by cutting off according to the length mentioned on parts catalogue or what is actually required on the vehicle.

5-3. Note that the drawings on the illustration page are for ready reference of spare parts number, not to be used as an assembly manual. When assembling, use "SUZUKI SERVICE MANUAL".

#### 6. MODEL NAME AND ENGINE NUMBER

MODEL	YEAR'S	TYPE	TRANSOM	ENGINE No.
DT6SVG	'86	00601	S,L	00601-610001~
DT6SVH	'87	00601	S,L	00601-701001~
DT6SVJ	'88	00601	S,L	00601-817660~
DT6SK	'89	00601	S,L	00601-920870~
DT6SL	'90	00601	S,L	00601-011001~
DT6SM	'91	00601	S,L	00601-131001~
DT6SN	'92	00601	S,L	00601-231001~
DT6SP	'93	00601	S,L	00601-351001~
DT6SR	'94	00601	S,L	00601-461001~
DT6SS	'95	00601	S,L	00601-581001~
DT6ST	'96	00601	S,L	00601-651001~
DT6SV	'97	00601	S,L	00601-751001~
DT6SW	'98	00601	S,L	00601-861001~
DT6SX	'99	00601	S,L	00601-971001~
DT6SY	'00	00601	S,L	00601-030001~
DT6SK1	'01	00601	S,L	00601-151001~
DT6SK2	'02	00601	S,L	00601-251001~

FIG.1

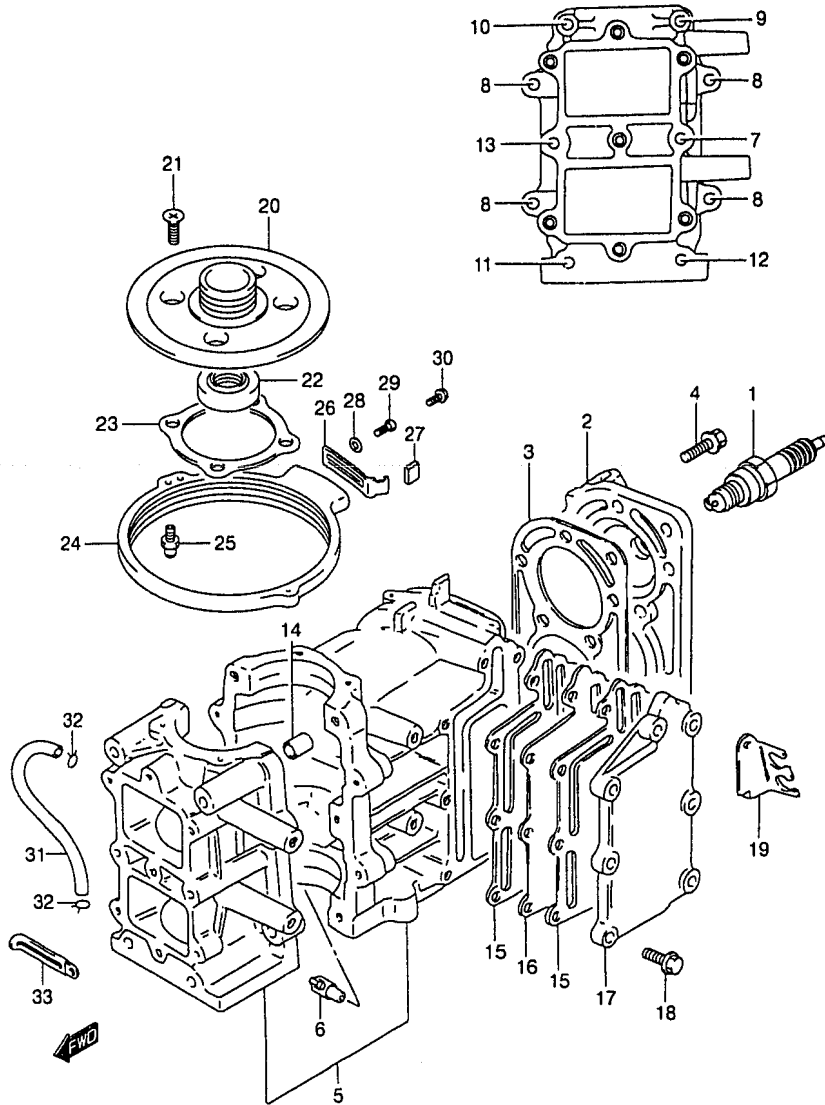
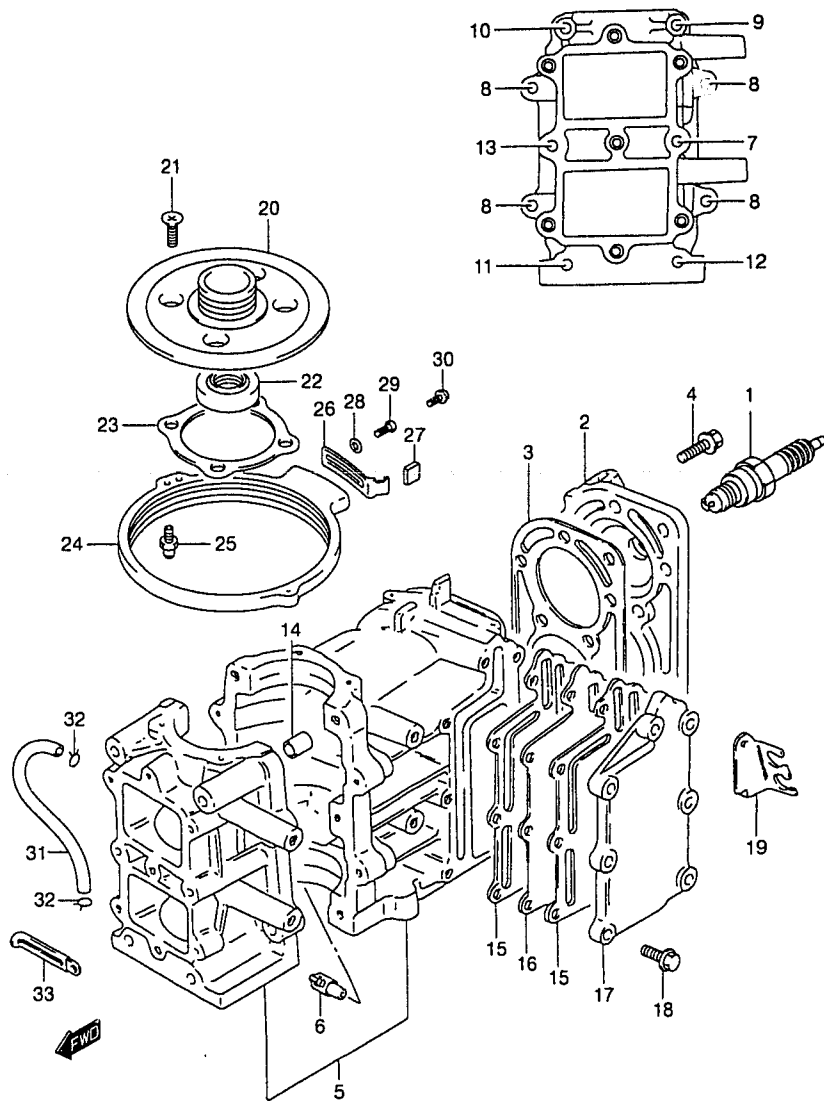

FIG.1 ( B-2) CYLINDER

REF.NO.	PART NO.	DESCRIPTION	QTY.	REMARKS
1	09482-00535	SPARK PLUG (BR6HS-10)	2	
2-1	11110-98100-0ED	HEAD, CYLINDER	1	
2-2	11110-98100-0EP	HEAD, CYLINDER	1	MODEL:02
3	11141-98130	GASKET	1	
4	01560-08357	BOLT	8	
5-1	11301-98154-0ED	CYLINDER / CRANKCASE ASSY	1	~MODEL:94
5-2	11301-981D2-0ED	CYLINDER / CRANKCASE ASSY	1	MODEL:95-01 W/DECOMP
5-3	11301-981D2-0EP	CYLINDER / CRANKCASE ASSY	1	MODEL:02 W/DECOMP
5-4	11301-98182-0ED	CYLINDER / CRANKCASE ASSY	1	OPT
5-5	11301-98183-0ED	CYLINDER / CRANKCASE ASSY	1	OPT MODEL:01
5-6	11301-98183-0EP	CYLINDER / CRANKCASE ASSY	1	OPT MODEL:02
6	16710-95D10	.VALVE, CHECK	1	
7	09103-06189	.BOLT, NO.7 (6X110)	1	
8	01550-06307	.BOLT, NO.1	4	
9	01550-06457	.BOLT, NO.2	1	
10	01550-06557	.BOLT, NO.5	1	
11	01550-06557	.BOLT, NO.3	1	
12	01550-06607	.BOLT, NO.6	1	
13	01550-06757	.BOLT, NO.4	1	
14	04211-09109	.DOWEL PIN	2	
15	14151-98111	GASKET, EXHAUST COVER	2	
16	14131-98102	PLATE	1	
17-1	14141-98100-0ED	COVER, EXHAUST	1	
17-2	14141-98100-0EP	COVER, EXHAUST	1	MODEL:02
18	01550-06257	BOLT (6X25)	7	
19-1	33883-98102-0ED	STAY, HIGH TENSION CORD	1	
19-2	33883-98102-0EP	STAY, HIGH TENSION CORD	1	MODEL:02
20	11411-98500	HOUSING, UPPER OIL SEAL	1	
21-1	09126-06008	SCREW (6X16)	4	
21-2	02122-06167	SCREW	4	MODEL:95-02
22	09283-20006	OIL SEAL	1	

COLOR : 0ED (GRAY) OEP (BLACK)

FIG.1



QTY.

REF.NO.	PART NO.	DESCRIPTION	REMARKS
23	11413-98510	GASKET, UPPER OIL SEAL HOUSING	1
24-1	19151-98101-0ED	RETAINER, STATOR	1
24-2	19151-98101-0EP	RETAINER, STATOR	1 MODEL:02
25	09119-06047	BALL, PIVOT	1
26	19172-98102	STOPPER	1
27	09352-50823-600	HOSE (5.0X8.2X600)	1 L:600→5.5
28	09160-05028	WASHER	2 MODEL:86
29	02112-05127	SCREW	2 MODEL:86
30-1	09136-05042	SCREW (5X12)	2 MODEL:87-94
30-2	02112-05107	SCREW	2 MODEL:95-02
31	09355-25705-600	HOSE, LUBRICATION	1 L:600→240
32	09401-06101	CLIP	2
33	09404-06432	CLAMP	1

COLOR : 0ED (GRAY) 0EP (BLACK)

FIG.2

FIG.2 ( B-4) CRANKSHAFT

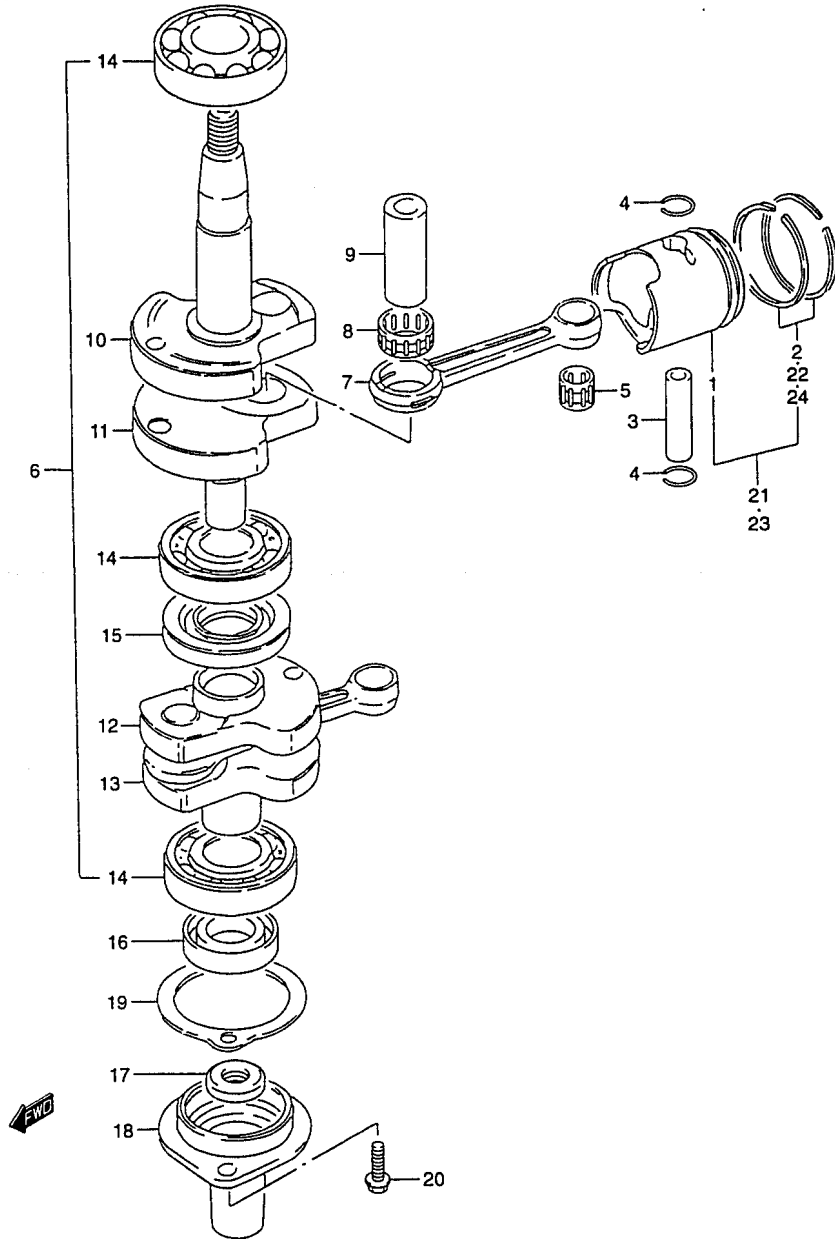

REF.NO.	PART NO.	DESCRIPTION	QTY.	REMARKS
1	12110-96103	PISTON	2	
2	12140-99604	RING SET	2	
3	12151-35400	PIN	2	
4	09381-12001	CIRCLIP	4	
5	09263-12023	BEARING	2	
6	12200-98106	CRANKSHAFT ASSY	1	
7	12161-96000	ROD, CONNECTING	2	
8	09263-17022	BEARING (17X23X14)	2	
9	12211-96001	PIN	2	
10	12221-98105	CRANKSHAFT, UPPER	1	
11	12231-98102	WHEEL, UPPER CRANKSHAFT	1	
12	12232-98101	WHEEL, LOWER CRANKSHAFT	1	
13	12240-98102	CRANKSHAFT, LOWER	1	
14	09262-20069	BEARING	3	
15	09289-22004	OIL SEAL, MIDDLE CRANKSHAFT	1	
16	09283-20053	OIL SEAL, LOWER CRANKSHAFT	1	
17	09283-10003	OIL SEAL, DRIVESHAFT UPPER	1	
18	11431-98502	HOUSING, UNDER OIL SEAL	1	
19	11433-98510	GASKET, UNDER OIL SEAL HOUSING	1	
20-1	09117-06031	BOLT (6X20)	2	
20-2	09116-06106	BOLT (6X20)	2	MODEL:99-02
21	12100-96103-025	PISTON SET (OS:0.25)	2	OPT
22	12140-28630-025	RING SET, PISTON (OS:0.25)	2	OPT
23	12100-96103-050	PISTON SET (OS:0.50)	2	OPT
24	12140-28630-050	RING SET, PISTON (OS:0.50)	2	OPT

**FIG.3**

FIG.3 ( B-5) REED VALVE

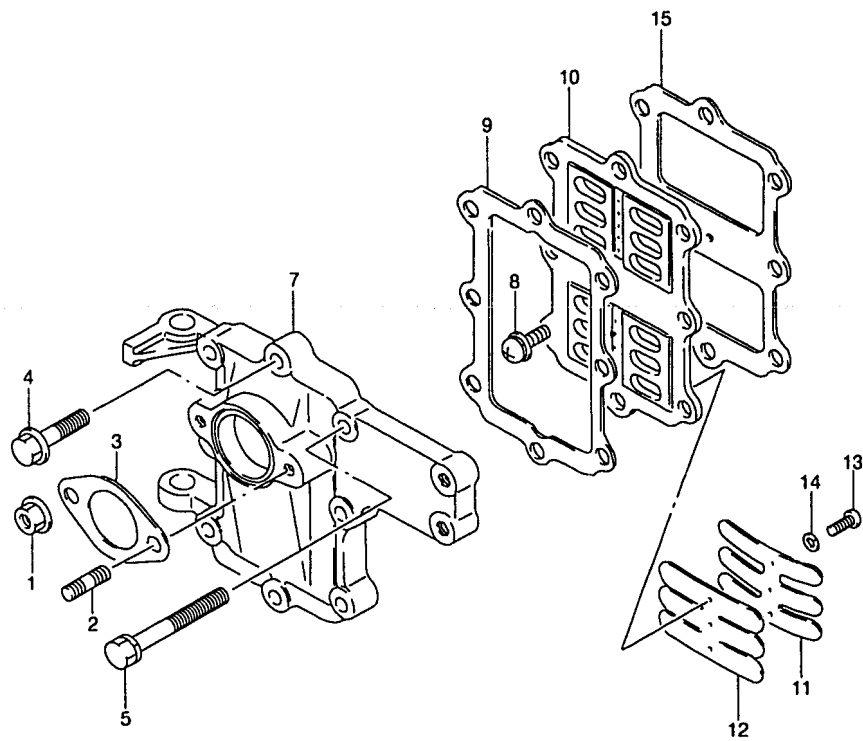

REF.NO.	PART NO.	DESCRIPTION	QTY.	REMARKS
1	08316-10067	NUT	2	
2	01411-06167	STUD BOLT	2	
3	13125-98310	GASKET, CARBURETOR	1	
4	01550-06307	BOLT 1	5	
5	01570-06607	BOLT 2	1	
7	13111-98111-0ED	CASE, INLET	1	
8	02112-76163	SCREW	1	
9	13121-98120	GASKET, INLET	1	
10	13150-98101	VALVE ASSY, REED	1	
11	13152-98100	STOPPER, REED VALVE	2	
12	13153-98100	VALVE, REED	2	
13	02112-03063	SCREW	6	
14	09162-03001	LOCK WASHER	6	
15	13122-98110	GASKET, VALVE SEAT	1	

COLOR : 0ED (GRAY)

FIG.4

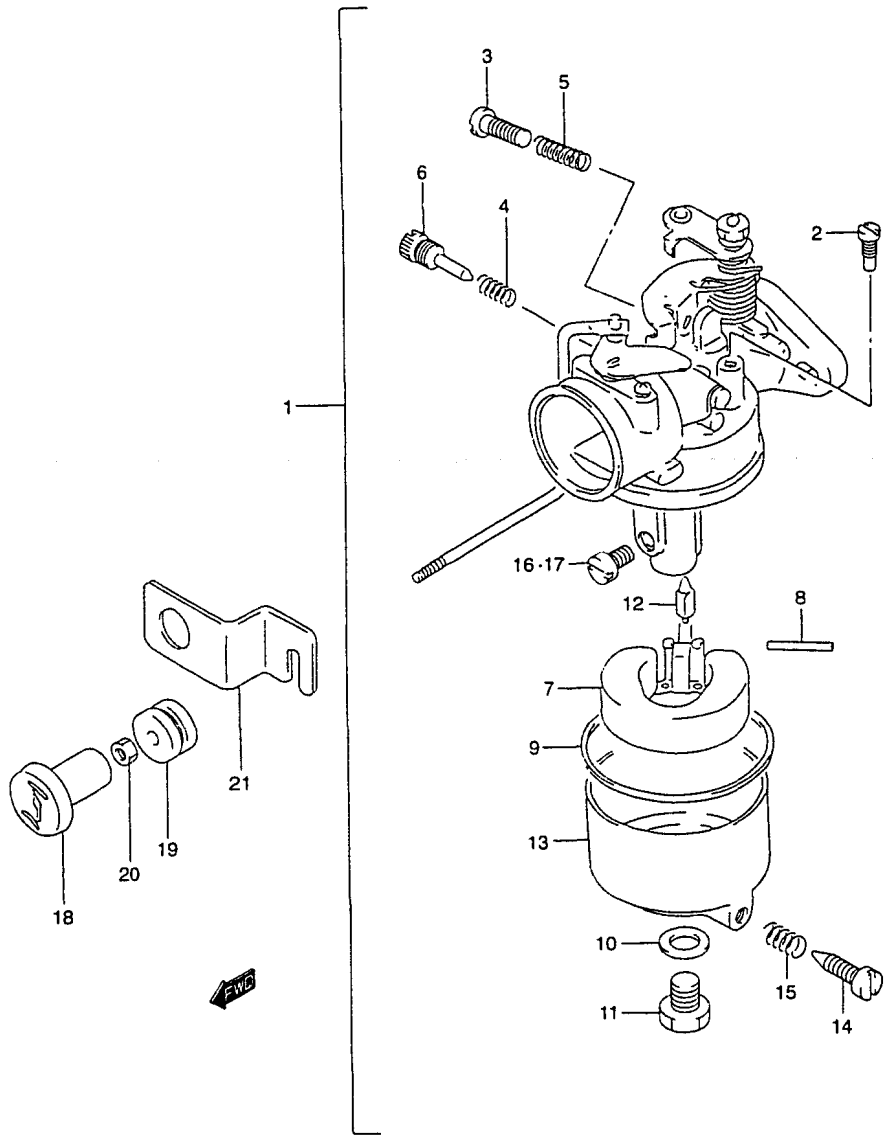

FIG.4 ( B-6)

CARBURETOR

REF.NO.	PART NO.	DESCRIPTION	QTY.	REMARKS
1-1	13200-98121	CARBURETOR ASSY (S)	1	
1-2	13200-98131	CARBURETOR ASSY (L)	1	
2	09492-40010	.PILOT, JET (#40)	1	
3	13534-98900	.SCREW, THROTTLE STOP	1	
4	13268-96111	.SPRING	1	
5	13268-92910	.SPRING	1	
6	13269-98300	.SCREW, PILOT AIR	1	
7	13250-98310	.FLOAT	1	
8	13254-98300	.PIN, FLOAT	1	
9	13251-98300	.GASKET, FLOAT CHAMBER	1	
10	13343-98520	.GASKET	1	
11	13613-98300	.BOLT	1	
12	13371-98300	.NEEDLE ASSY	1	
13	13245-98900	.CHAMBER, FLOAT	1	
14	13616-93900	.ADJUSTER	1	
15	13268-96111	.SPRING	1	
16-1	09491-20019	.JET, MAIN (#100)	1	TYPE:S
16-2	09491-23012	.JET, MAIN (#115)	1	TYPE:L
17-1	09491-21023	JET, MAIN (#105)	1	OPT
17-2	09491-22013	JET, MAIN (#110)	1	OPT
17-3	09491-24026	JET, MAIN (#120)	1	OPT
17-4	09491-25014	JET, MAIN (#125)	1	OPT
18	13631-93501	KNOB, STARTER	1	
19	09320-04009	BUSHING, STARTER KNOB	1	
20	09140-04007	NUT	1	
21	13635-98510	GUIDE, CHOKE ROD	1	

FIG.5

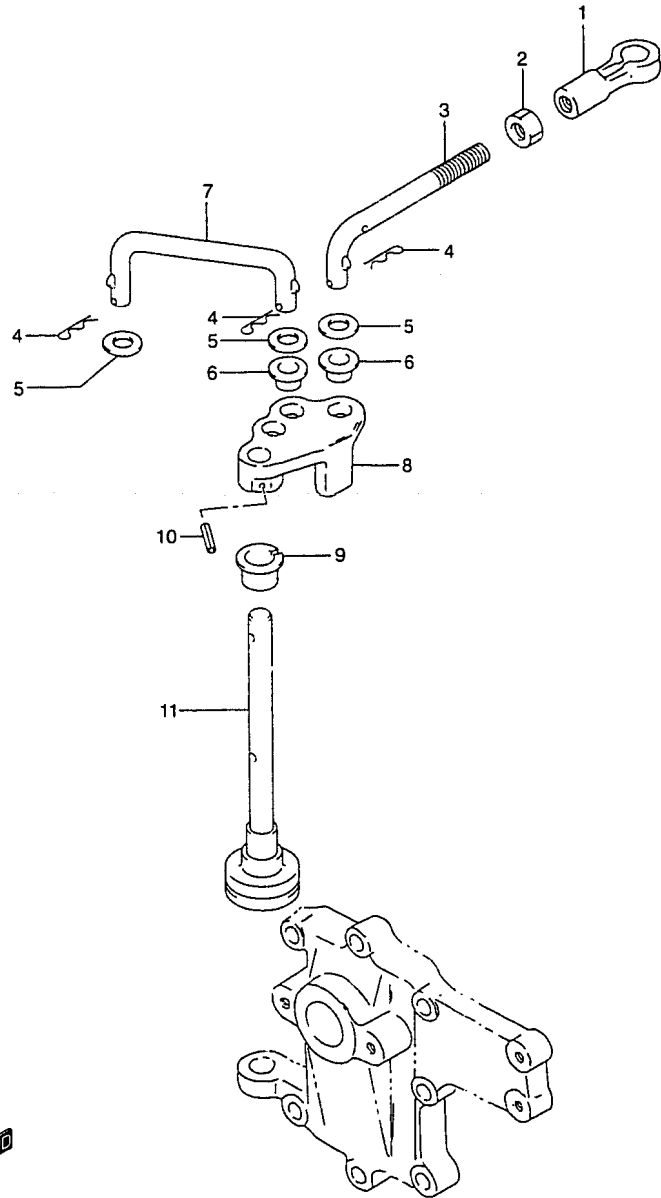

FIG.5 ( B-7)

THROTTLE CONTROL

REF.NO.	PART NO.	DESCRIPTION	QTY.	REMARKS
1	67463-95200	CONNECTOR	1	
2	09140-05005	NUT	1	
3	19171-98101	LINK	1	
4	09385-05004	CLIP	3	
5	09160-05029	WASHER (5.5X12X0.8)	3	
6	09306-05002	BUSHING	2	
7	19111-98110	LINK	1	
8	19181-98120	LEVER, THROTTLE	1	
9	63225-93200	BUSHING	1	
10	63227-93200	PIN	1	
11	19110-98100	SHAFT, THROTTLE LEVER	1	





**FIG.6**

**FIG.6 ( B- 8) FUEL PUMP (~MODEL:94)**

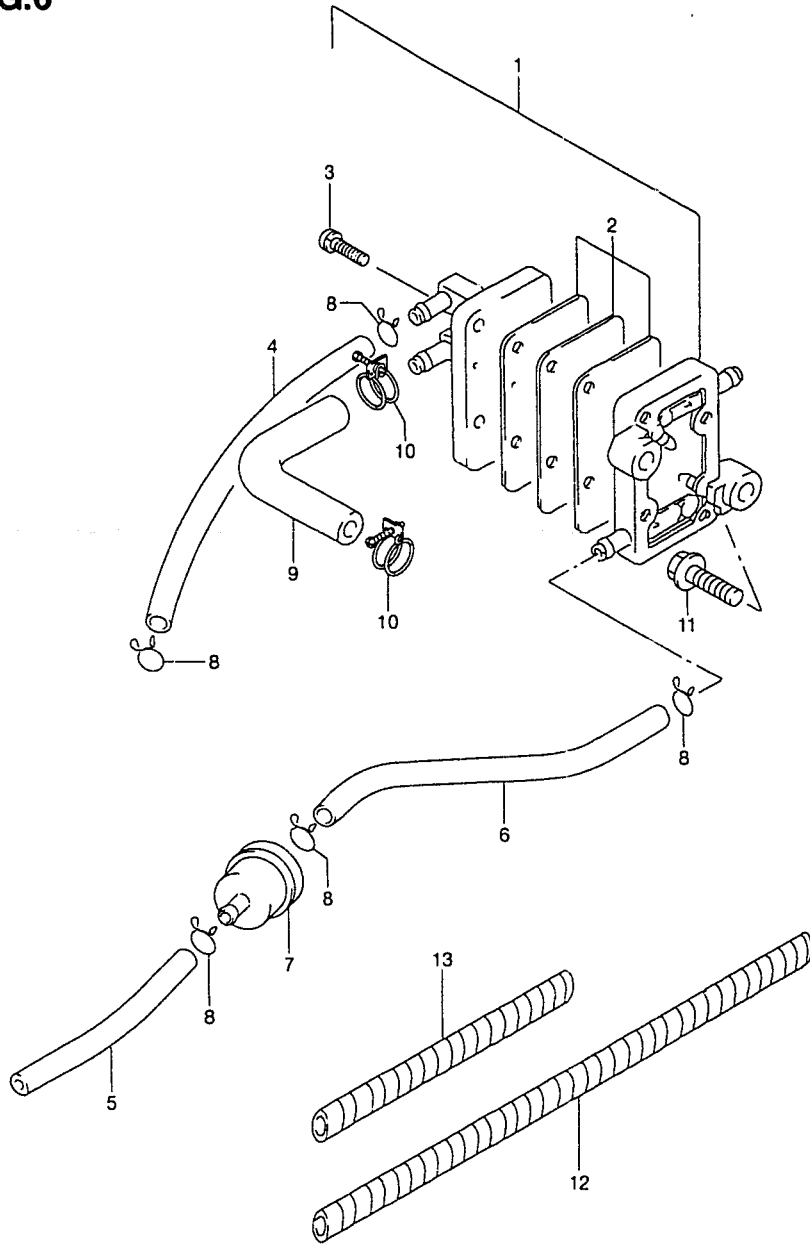

REF.NO.	PART NO.	DESCRIPTION	QTY.	REMARKS
1	15100-98110	PUMP ASSY, FUEL	1	
2	15170-98110	.DIAPHRAGM SET	1	
3	15251-98101	.SCREW	4	
4	09352-50903-600	HOSE, FUEL (PUMP-CARBURETOR)	1	L:600→270
5	09352-50903-600	HOSE, FUEL (CONNECTOR-FILTER)	1	L:600→35
6	09352-50903-600	HOSE, FUEL (FILTER-PUMP)	1	L:600→210
7	15410-98500	FILTER, FUEL	1	
8	09401-08410	CLIP	6	
9	15311-98100	HOSE, VACUUM	1	
10	09400-13302	CLAMP	2	
11	01550-06207	BOLT	2	
12	38423-95510	PROTECTOR, FUEL HOSE	1	L:150→100
13	38423-95510	PROTECTOR, FUEL HOSE	1	L:150→50

REFER TO FIG.6A(B-9) FOR MODEL:95-02

FIG.6A

FIG.6A ( B-9) FUEL PUMP (MODEL:95-02)

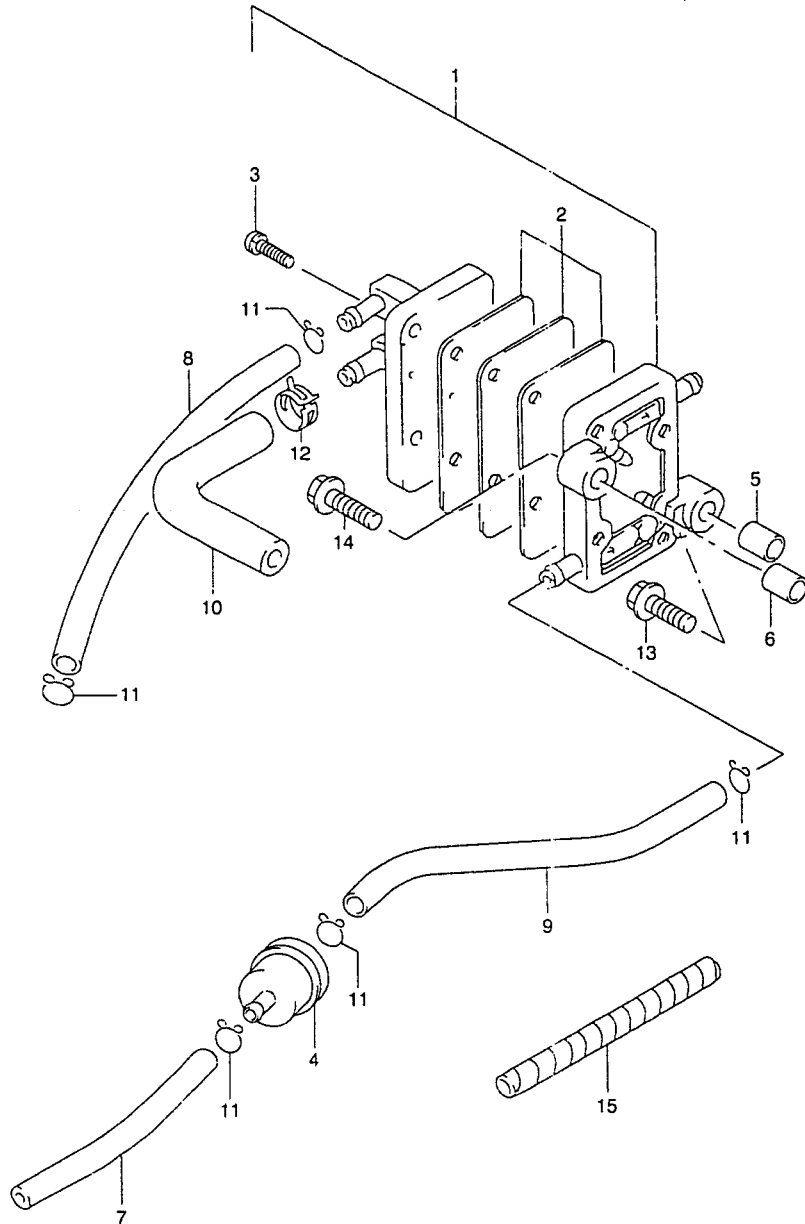

REF.NO.	PART NO.	DESCRIPTION	QTY.	REMARKS
1	15100-98610	PUMP ASSY, FUEL	1	
2	15170-98110	.DIAPHRAGM SET	1	
3	15251-98101	.SCREW	4	
4	15410-98500	FILTER, FUEL	1	
5	09180-06144	SPACER, FUEL PUMP	1	L:19
6	09180-06196	SPACER, FUEL PUMP	1	L:28
7	09352-50903-600	HOSE, FUEL (CONN TO FILTER)	1	L:600→35
8	09352-50903-600	HOSE, FUEL (PUMP TO CARB)	1	L:600→210
9	09352-50903-600	HOSE, FUEL (FILTER TO PUMP)	1	L:600→350
10	09355-54115-600	HOSE, VACUUM	1	L:600→11
11	09401-08410	CLIP	6	
12	09401-10409	CLIP, VACCUM	1	
13	01550-06407	BOLT	1	
14	U1550-06507	BOLT	1	
15	38423-95510	TUBE	1	L:150→50

**FIG.7**

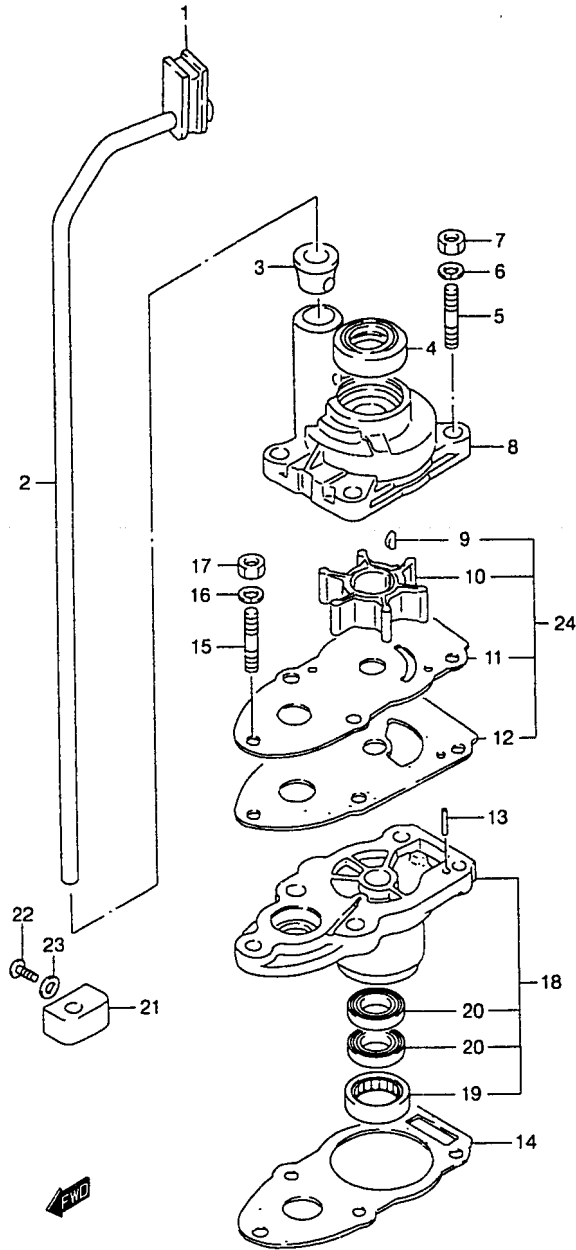

REF.NO.	PART NO.	DESCRIPTION	QTY.	REMARKS
1	17563-98500	GROMMET	1	
2-1	17561-98510	TUBE, WATER (S)	1	
2-2	17561-98520	TUBE, WATER (L)	1	
3	17415-98501	BUSHING	1	
4	09289-10002	OIL SEAL	1	
5	09108-06025	STUD BOLT	4	
6	09162-06006	LOCK WASHER	4	
7	09140-06020	NUT	4	
8	17411-98505	CASE, WATER PUMP	1	
9	09420-03002	KEY	1	
10	17461-98502	IMPELLER	1	
11	17471-98503	PLATE	1	
12	17472-98503	GASKET	1	
13	09202-04008	DOWEL PIN	1	
14	56132-98510	GASKET, DRIVE SHAFT HOUSING	1	
15	09108-06063	STUD BOLT	1	
16	09162-06006	LOCK WASHER	1	
17	09140-06020	NUT	1	
18	56130-98521	HOUSING, DRIVE SHAFT	1	
19	09263-15019	BEARING, DRIVE SHAFT	1	
20	09282-10009	SEAL, DRIVE SHAFT OIL	2	
21-1	17441-98512	GUIDE, WATER TUBE (S)	1	
21-2	17441-98521	GUIDE, WATER TUBE (L)	1	
22	09125-05047	SCREW (5X14)	1	
23	09161-05010	WASHER	1	
24	17400-98550	WATER PUMP REPAIR KIT	1	OPT

**FIG.8**

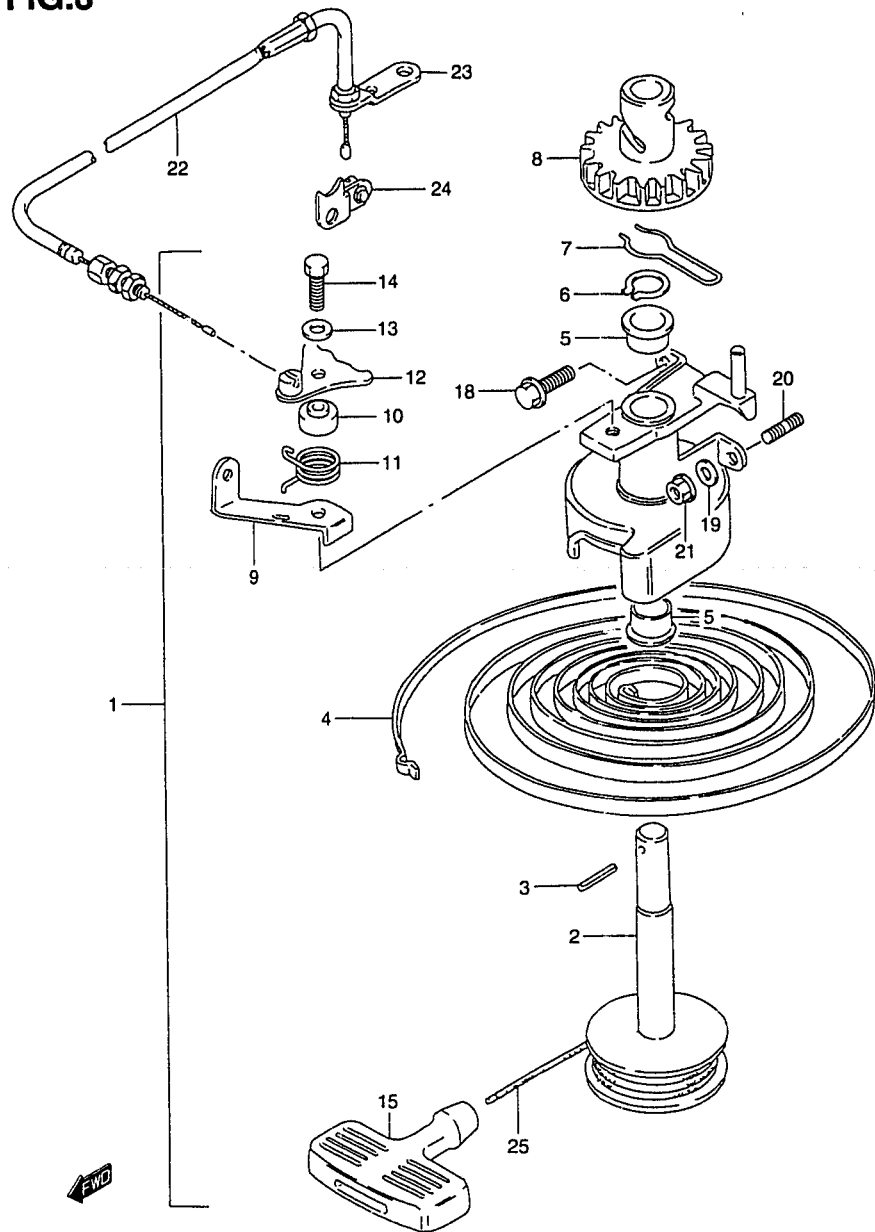

FIG.8 ( C-2)

STARTER

QTY.

REF.NO.	PART NO.	DESCRIPTION	REMARKS
1	18100-98115	STARTER ASSY, RECOIL	1
2	18121-98100	.REEL, STARTER	1
3	18344-98100	.PIN, STARTER	1
4	18142-98300	.SPRING, RECOIL	1
5	18253-98300	.BUSHING, STARTER	1
6	18255-98301	.CIRCLIP, STARTER	1
7	18271-98100	.SPRING, FRICTION	1
8	18261-98100	.PINION, STARTER	1
9	18291-98102	.HOLDER, CABLE	1
10	18283-98102	.SPACER	1
11	18284-98101	.SPRING, RETURN	1
12	18280-98102	.STOPPER	1
13	18335-98100	.WASHER	1
14	18332-98100	.BOLT	1
15	18210-93002	.GRIP ASSY	1
18	01550-06167	BOLT	1
19	09164-05002	WASHER	1
20	01421-06127	STUD BOLT	1
21	08316-10067	NUT	1
22	18630-98101	CABLE ASSY, INTER LOCK	1
23	18642-98101	HOLDER, CABLE	1
24	18650-98101	ARM, INTER LOCK	1
25	99000-81157-50M	ROPE	1

OPT L:50000→1500  
NOT FOR US MARKET

REFER TO FIG.8A(C-3) FOR MODEL:95-02

**FIG.8A**

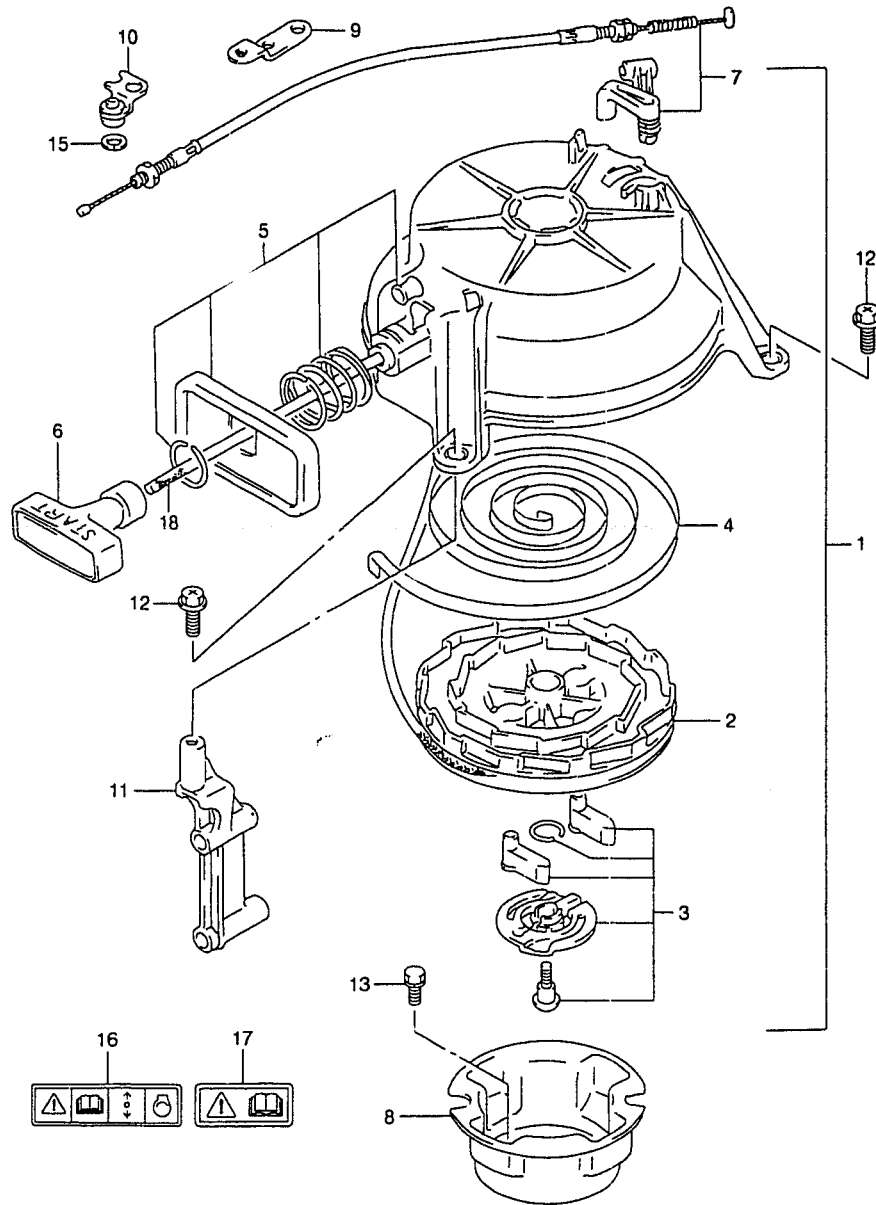

FIG.8A ( C-3)

STARTER (MODEL:95-02)

QTY.

REF.NO.	PART NO.	DESCRIPTION	REMARKS
1	18100-98131	STARTER ASSY, RECOIL	1
2	18120-98130	.REEL	1
3	18130-98130	.RATCHET SET	1
4	18142-98130	.SPRING, SPIRAL	1
5	18190-98130	.GUIDE SET	1
6	18210-98130	.KNOB	1
7-1	18200-98810	.NSI SET	1 -MODEL:96
7-2	18280-98131	.NSI SET	1 MODEL:97-02
8	18411-98110	CUP, STARTER	1
9	18642-98101	HOLDER, INTERLOCK CABLE	1
10	18650-98101	ARM, INTERLOCK	1
11	18711-98100-0ED	BRACE, RECOIL STARTER	1
12	02162-06207	BOLT	3
13	01570-06127	BOLT	3
15	18653-98110	RING, SNAP	1
16	69711-93E10	LABEL, CAUTION	1
17	69712-93E10	LABEL, CAUTION	1 MODEL:01,02
18	99000-81157-50M	ROPE	1 OPT L:50000→1450 NOT FOR US MARKET

FIG.9

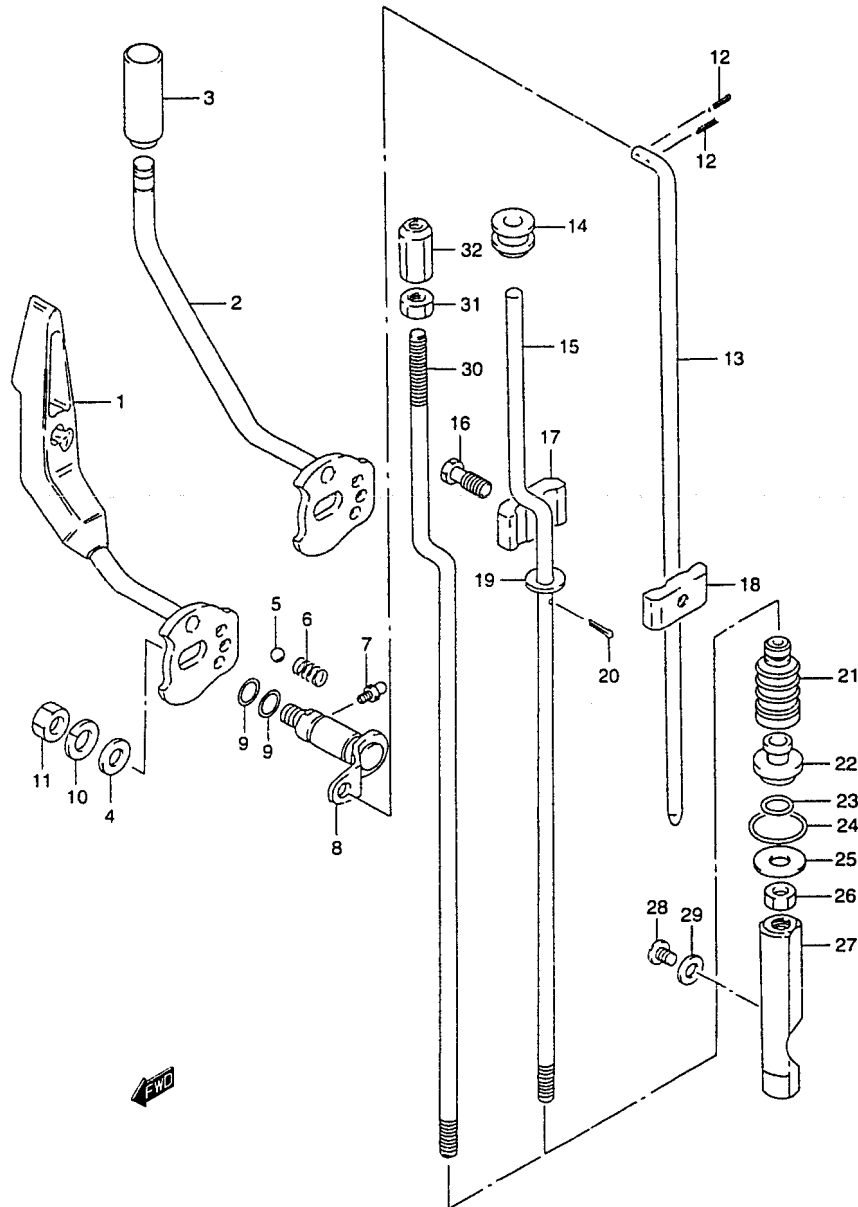

FIG.9 ( C-4)

CLUTCH LEVER

QTY.

REF.NO.	PART NO.	DESCRIPTION	REMARKS
1	21110-98102-0ED	LEVER, CLUTCH (GRAY)	1
2	21110-98503	LEVER, CLUTCH	1 MODEL:00-02
3	21141-98500	KNOB, CLUTCH LEVER	1 MODEL:00-02
4	09160-08082	WASHER (8.5X16X1.2)	1 MODEL:00-02
5	09260-10005	BALL, CLUTCH NOTCH	1
6	09440-07021	SPRING, CLUTCH NOTCH	1
7	22511-99010	GREASE NIPPLE, CLUTCH	1
8	21210-98503	SHAFT, CLUTCH LEVER	1
9	09280-09005	O RING (D:1.9 ID:8.6)	2
10	09162-08007	LOCK WASHER (8.2X15.4X2.0)	1
11-1	09140-08016	NUT	1
11-2	09140-08003	NUT	1 MODEL:01,02
12	09204-01002	COTTER PIN, CLUTCH ROD	2
13-1	23111-98510	ROD, CLUTCH (S)	1
13-2	23111-98520	ROD, CLUTCH (L)	1
14	09320-05017	BUSHING, SHIFTING ROD	1
15-1	25111-98110	ROD, SHIFTING (S)	1 STD -MODEL:94 OPT MODEL:95-00
15-2	25111-98120	ROD, SHIFTING (L)	1 STD -MODEL:94 OPT MODEL:95-00
16	09138-06037	BOLT, CLUTCH ROD	1
17	23311-99001	CONNECTOR, CLUTCH ROD 1	1
18	23321-99001	CONNECTOR, CLUTCH ROD 2	1
19-1	09160-06090	WASHER (6.5X13X1.0)	1 ~MODEL:96
19-2	09160-06036	WASHER (6.5X18X1.5)	1 MODEL:97-02
20	09204-01002	COTTER PIN, SHIFTING ROD	1
21	25222-93000	BOOT, SHIFTING ROD	1
22	25211-98501	GUIDE, SHIFTING ROD	1
23	09280-06004	O RING (D:3.5 ID:5.8)	1
24	09280-15007	O RING (D:2.4 ID:15.8)	1
25	08212-06201	WASHER, SHIFTING ROD GUIDE	1
26	08310-00063	NUT	1

**FIG.9**

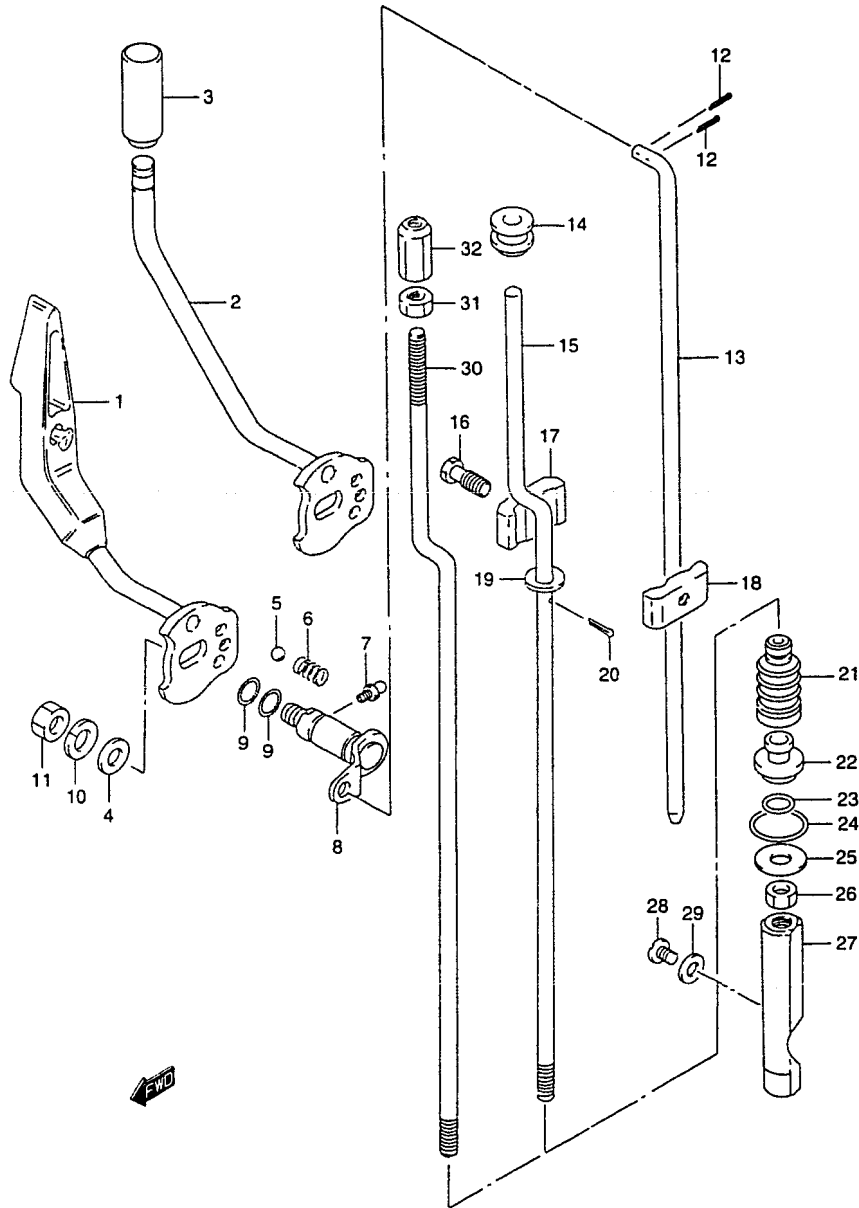

FIG.9 ( C-5)

CLUTCH LEVER

REF.NO.	PART NO.	DESCRIPTION	QTY.	REMARKS
27-1	25311-93100	CAM, SHIFTING	1	-MODEL:90
27-2	25311-98510	CAM, SHIFTING	1	MODEEL:91-02
28	09139-06035	SCREW, SHIFTING CAM STOP	1	
29	09168-06004	GASKET, CAM STOP SCREW	1	
30-1	25111-98511	ROD, SHIFTING (S)	1	MODEL:95-02
30-2	25111-98521	ROD, SHIFTING (L)	1	MODEL:95-02
31	09140-06020	NUT	1	MODEL:95-02
32	09159-06030	NUT, SHIFT ROD ADJUST	1	MODEL:95-02

FIG.10

QTY.

REF.NO.	PART NO.	DESCRIPTION	REMARKS
1	32101-98151	STATOR ASSY	1
2	32140-98121	.COIL ASSY, IGNITION	1
3	02112-05257	.SCREW	2
4	08321-01057	.LOCK WASHER	2
5	32150-98112	.SENSOR	1
6	02112-04107	.SCREW	2
7	08321-01043	.LOCK WASHER	2
8	32220-98110	.COIL ASSY, LIGHTING	1
9	02112-05303	.SCREW	2
10	08321-01057	.LOCK WASHER	2
11	32102-98132	FLYWHEEL	1
12	09140-12038	NUT	1
13	08321-01127	LOCK WASHER	1
14	08322-01127	WASHER	1
15	08341-31039	KEY	1
16	02122-05127	SCREW	2

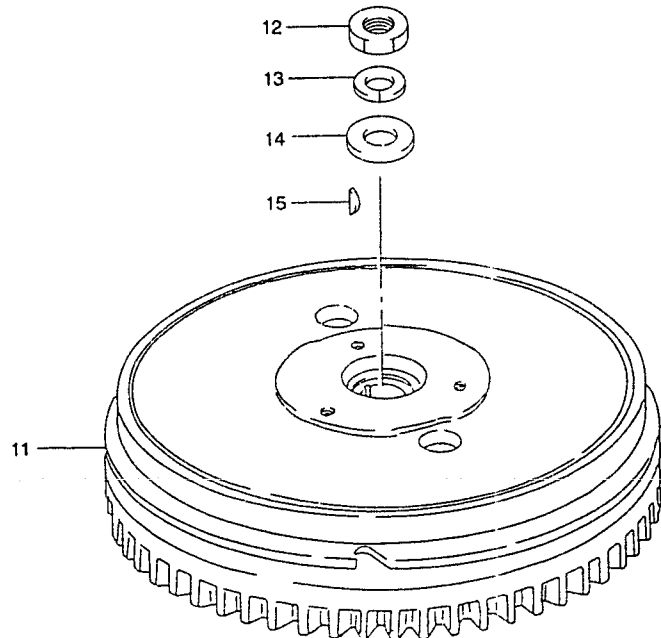

REFER TO FIG.10A(C-7) FOR MODEL:95-02

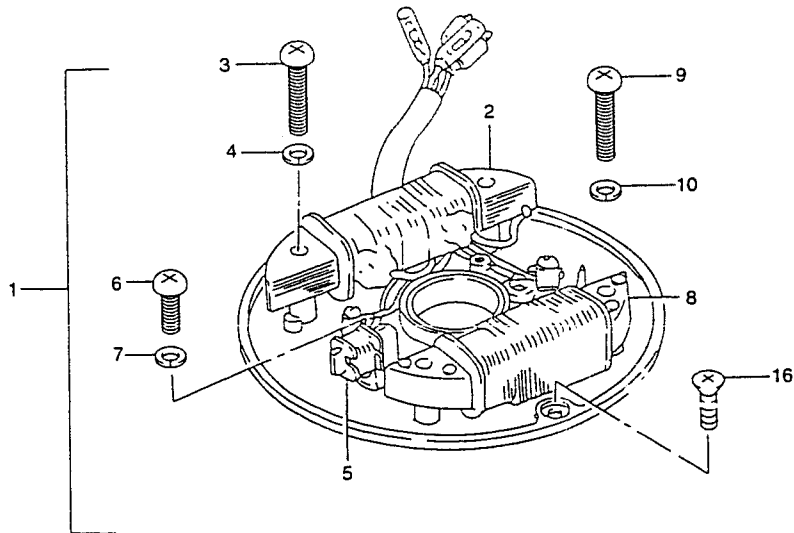



**FIG.10A**

QTY.

REF.NO.	PART NO.	DESCRIPTION	REMARKS
1	32101-99100	STATOR ASSY	1
2	32140-99100	.COIL, IGNITION PRIMARY	1
3	02112-05253	.SCREW	2
4	08321-01053	.LOCK WASHER	2
5	32200-99100	.LIGHTING COIL SET	1
6	02112-05303	.SCREW	2
7	08321-01053	.LOCK WASHER	2
8	32102-99100	FLYWHEEL	1
9	02122-05123	SCREW	2
10	09140-12777	NUT	1
11	08321-01123	WASHER, LOCK	1
12	08322-01123	WASHER	1
13	08341-31039	WOODRUFF KEY	1

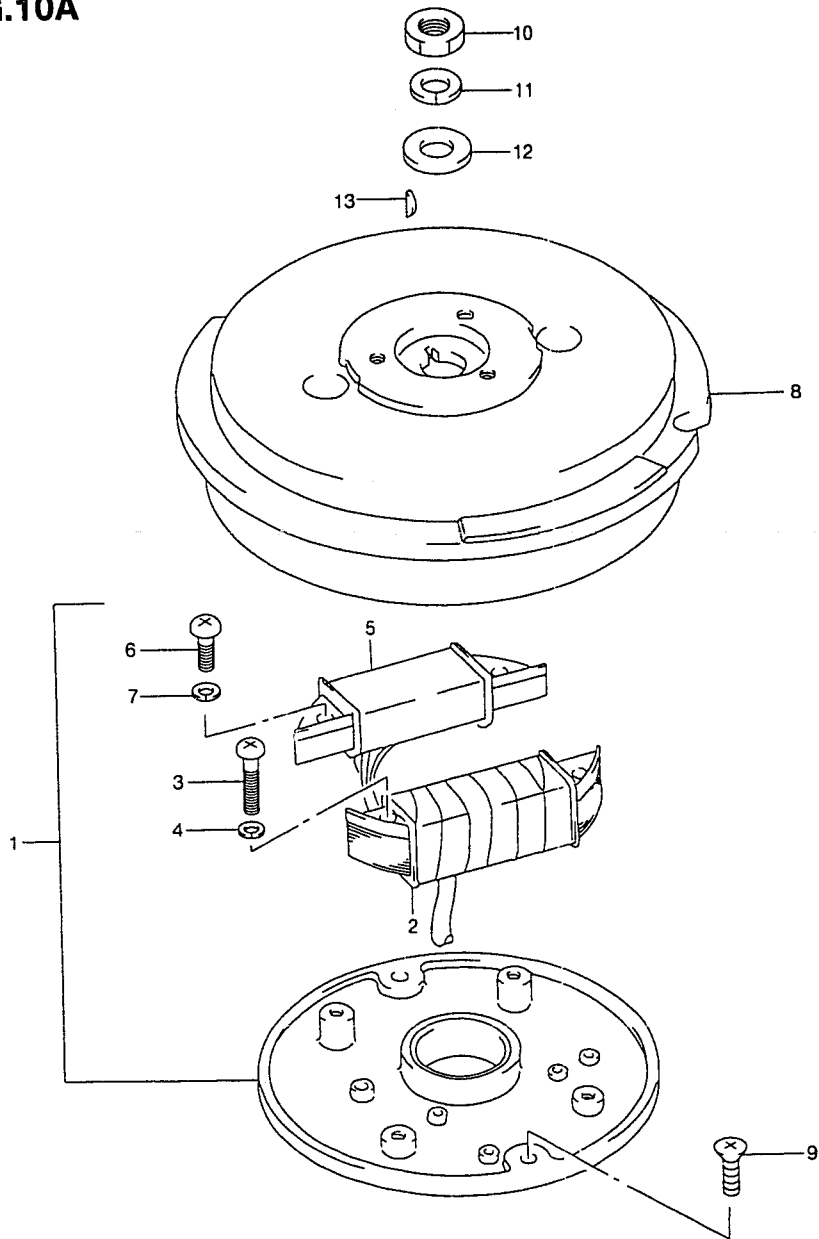

FIG.11

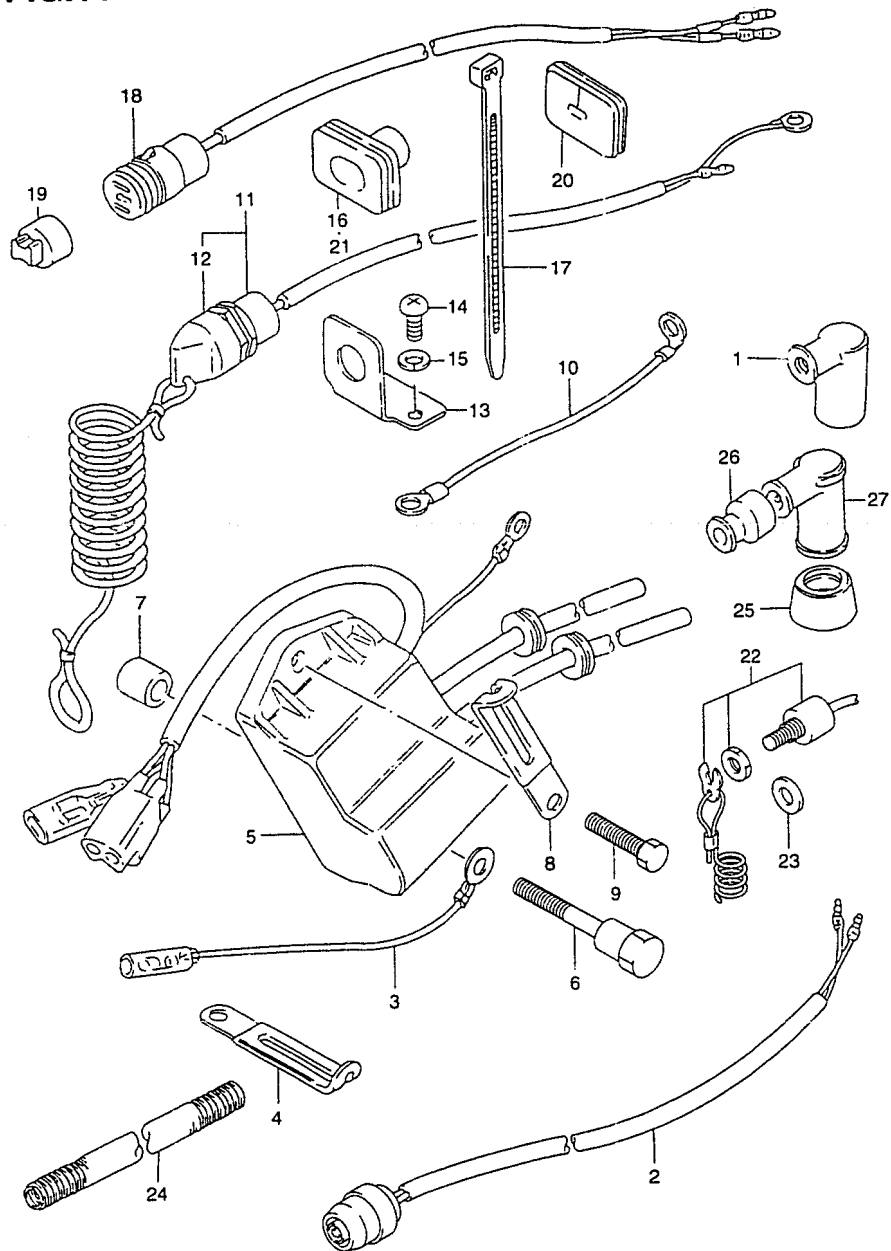

FIG.11 ( C-8)

ELECTRICAL

QTY.

REF.NO.	PART NO.	DESCRIPTION	REMARKS
1-1	33510-95520	CAP, SPARK PLUG	2
1-2	33510-98601	CAP, SPARK PLUG	2 OPT
2	37800-98572	SWITCH ASSY, ENGINE STOP	1 ~MODEL:92
3	37801-98300	LEAD, STOP SWITCH	1
4	09404-06432	CLAMP, SWITCH WIRE	1
5	32900-98110	CDI UNIT & IGNITION COIL	1 ~MODEL:94
6	01550-06457	BOLT, LOWER	1
7	09180-06079	SPACER	1
8	09404-06432	CLAMP, LEAD WIRE	1
9	01500-06207	BOLT, UPPER	1
10	36895-94400	LEAD, ENGINE GROUND	1
11	37830-89X50	SWITCH ASSY, EMERGENCY	1 ~MODEL:93
12	37823-94400	.CAP & ROPE	1
13	37950-98501	BRACKET	1
14	02112-04163	SCREW	2
15	08321-01043	LOCK WASHER	2
16	37824-98100	GROMMET	1
17	09407-25402	CLAMP	1
18	39601-95D00	RECEPTACLE ASSY, LIGHTING	1
19	36634-93910	.CAP	1
20	37824-92D00	GROMMET, EMERGENCY SW LEAD	1
21	39603-94400	GROMMET, RECEPTACLE	1 MODEL:93-94
22	37830-89E00	SWITCH ASSY, EMERGENCY/STOP	1 MODEL:93-94
23	09160-12067	WASHER	1 MODEL:93-94
24	33446-98E20	TUBE, SW WIRE	1 MODEL:94
25	33541-93950	SEAL, SPARK PLUG	2 ~MODEL:93
26	33542-38B00	SEAL, HIGH TENSION CORD	2 ~MODEL:93
27	33510-97313	CAP, SPARK PLUG	2 ~MODEL:93

REFER TO FIG.11A(C-9) FOR MODEL:95-02

**FIG.11A**

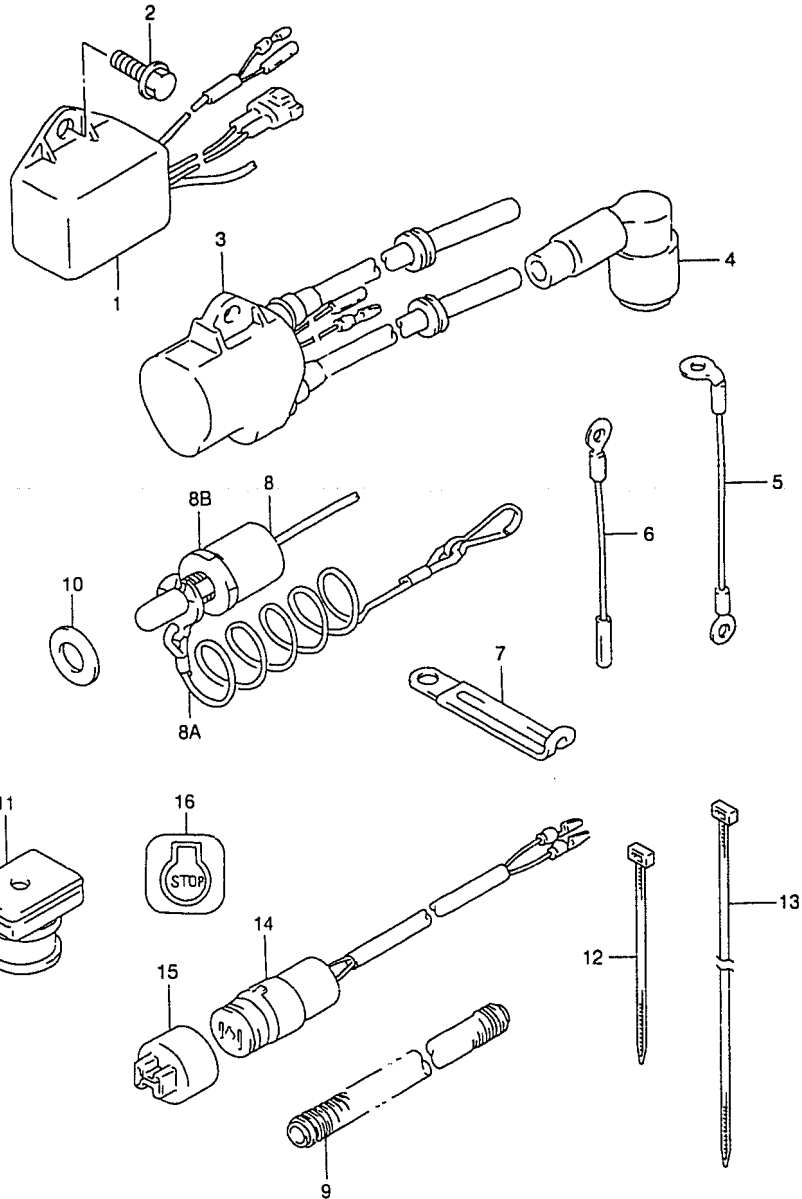

FIG.11A( C-9) ELECTRICAL (MODEL:95-02)

QTY.

REF.NO.	PART NO.	DESCRIPTION	REMARKS
1	32900-98120	CDI UNIT	1
2	01550-06207	BOLT	2
3	33410-98110	COIL, IGNITION	1
4	33510-98601	CAP, SPARK PLUG	2
5	36895-94400	LEAD, ENGINE GROUND	1
6	37801-98300	LEAD, STOP SW	1 OPT
7	09404-06432	CLAMP	1
8	37830-89E00	SWITCH, EMERGENCY & STOP	1
8A	37823-92E00	.PLATE, LOCK	1
8B	37826-92E00	.NUT	1
9	33446-98E20	TUBE, SW WIRE	1 L:500→100
10	09160-12067	WASHER	1
11	39603-94400	GROMMET, RECEPTACLE	1
12	09407-14403	CLAMP	1
13-1	09407-25402	CLAMP	1
13-2	09407-14407	CLAMP	1 MODEL:02
14	39601-95D00	RECEPTACLE, LIGHTING	1
15	36634-93910	.CAP	1
16	37835-95D00	LABEL, STOP	1

FIG.12

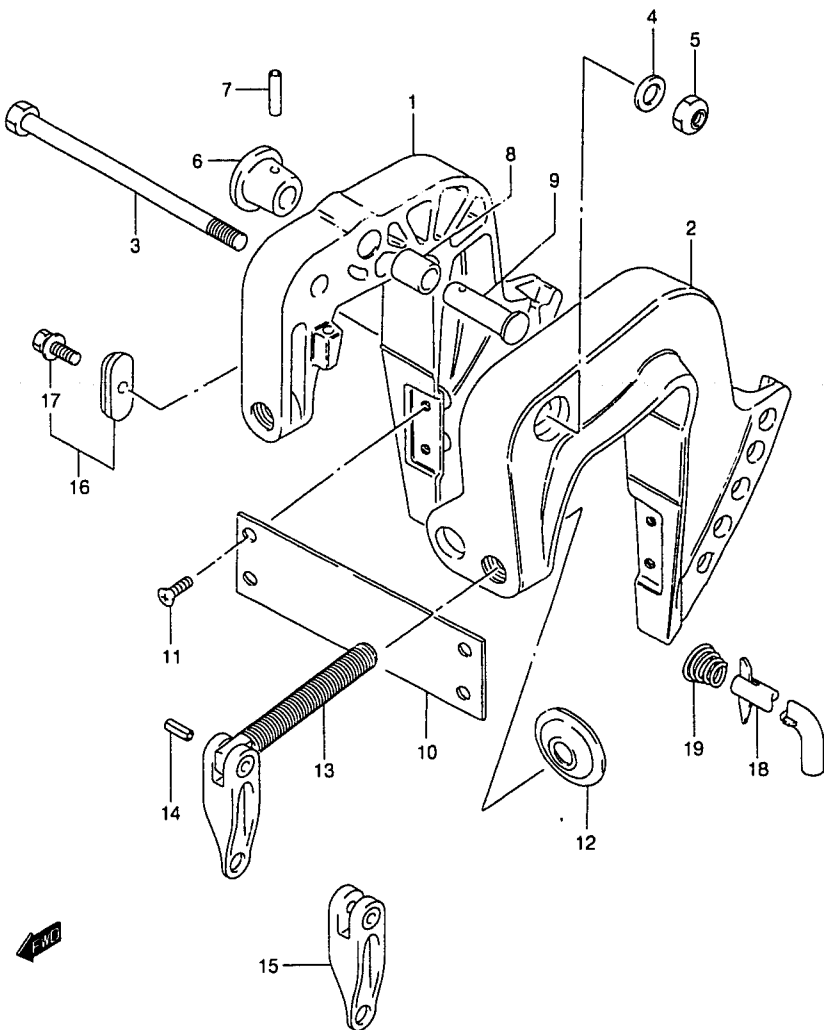

FIG.12 ( D-2) CLAMP BRACKET

REF.NO.	PART NO.	DESCRIPTION	QTY.	REMARKS
1-1	41111-98512-02M	BRACKET, CLAMP STBD	1	MODEL:86 →41100-98800-0ED USED WITH 41810-98500
1-2	41100-98800-0ED	BRACKET SET, CLAMP STBD & PORT	1	MODEL:89-98
1-3	41111-98551-0ED	BRACKET, CLAMP STBD	1	MODEL:99-01
1-4	41111-98551-0EP	BRACKET, CLAMP STBD	1	MODEL:02
2-1	41100-98800-0ED	BRACKET SET, CLAMP PORT & STBD	1	~MODEL:98
2-2	41121-98542-0ED	BRACKET, CLAMP PCRT	1	MODEL:99-01
2-3	41121-98542-0EP	BRACKET, CLAMP PORT	1	MODEL:02
3	09100-10190	BOLT (10X145)	1	
4	09160-10082	WASHER (10.5X19X2.0)	2	
5	09159-10050	NUT	1	
6	41221-93001	KNOB, TILT STOPPER	1	
7-1	09205-03032	PIN (L:8)	1	
7-2	09205-03012	PIN (L:16)	1	MODEL:98-02
8	09300-12009	BUSHING	1	
9	09200-12003	PIN	1	
10	41311-98101	PLATE	1	
11	09125-06053	SCREW (6X16)	4	
12	41213-98100	PLATE	2	
13	41210-98610	SCREW	2	
14	09205-05013	PIIN	2	MODEL:89,90
15	41212-99000-0ED	HANDLE	2	MODEL:89,90
16	41811-98500	ZINC SET	1	
17	09116-06121	BOLT (6X25)	1	
18	45420-98101	PIN, TILT LOCK	1	
19	09441-17001	SPRING	1	

COLOR : 02M (SILVER) 0ED (GRAY) 0EP (BLACK)

FIG.13

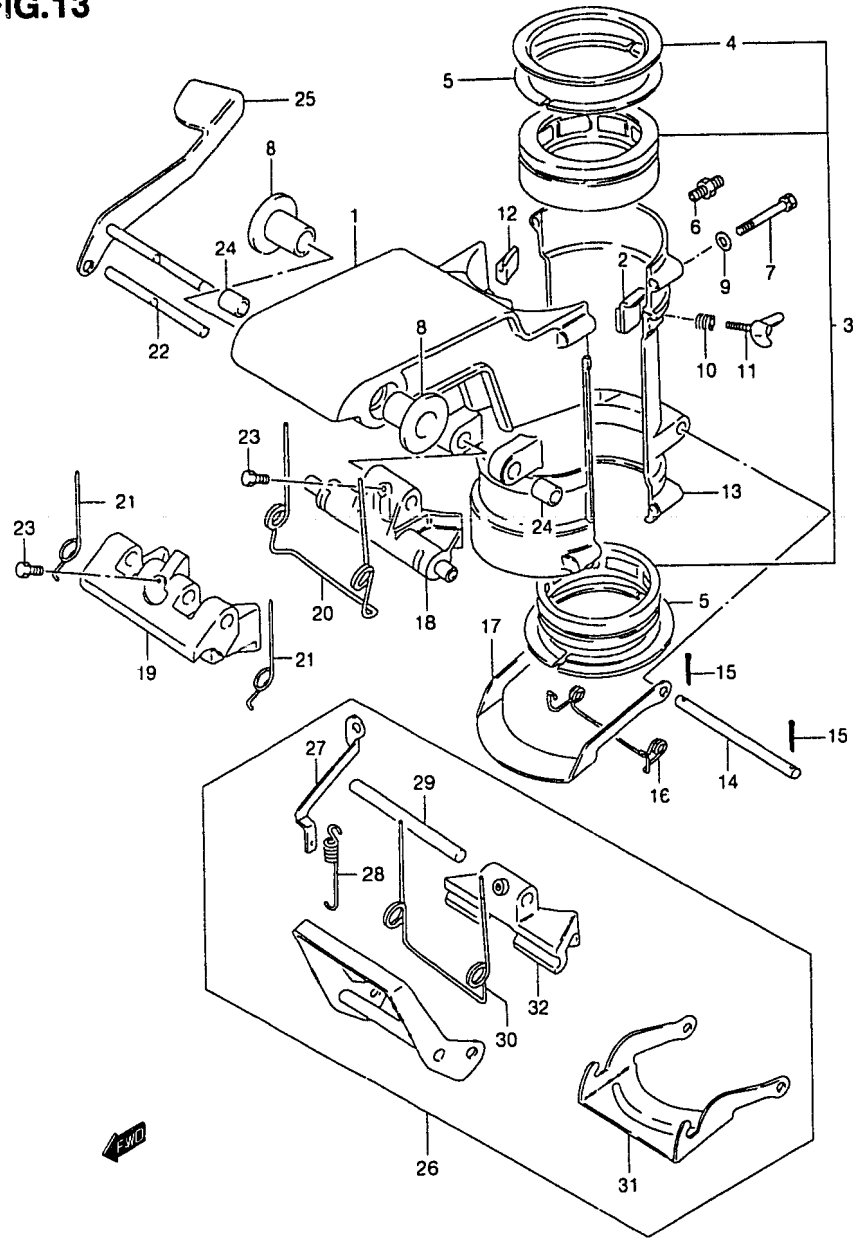

FIG.13 ( D-3)

SWIVEL BRACKET

QTY.

REF.NO.	PART NO.	DESCRIPTION	REMARKS
1-1	43111-98110-0ED	BRACKET, SWIVEL (GRAY)	1
1-2	43111-98110-0EP	BRACKET, SWIVEL (BLACK)	1 MODEL:02
2-1	43410-98501	ADJUSTER, STEERING	1 MODEL:86-91
2-2	43410-98503	ADJUSTER, STEERING	1 MODEL:92-02
3	43710-98500	BUSH SET, STEERING	1 OPT
4	43712-98503	PLATE	1
5	43713-98500	BUSH, STEERING PIECE	4
6	22511-99010	GREASE NIPPLE	4
7	09117-06043	BOLT (6X40)	4
8	09306-10011	BUSH	2
9	09160-06090	WASHER	4 -MODEL:96
10	09440-09025	SPRING	1
11	09119-06060	BOLT	1
12	43417-98500	RUBBER, STEERING ADJUSTER BACK	1
13-1	43121-98110-0ED	COVER, SWIVEL BRKT (GRAY)	1
13-2	43121-98110-0EP	COVER, SWIVEL BRKT (BLACK)	1 MODEL:02
14	09200-08045	PIN	1
15	09204-01002	COTTER PIN	2
16	45212-98501	SPRING	1
17-1	45231-98502	ARM	1 STD -MODEL:94 OPT MODEL:96-00
17-2	45231-98111	ARM, REVERSE LOCK	1 MODEL:95-02
18	45411-98501-0ED	BLOCK, THRUST (GRAY)	1 STD -MODEL:94 OPT MODEL:95-00
19-1	45411-98110-0ED	BLOCK, THRUST (GRAY)	1 MODEL:95-01
19-2	45411-98110-0EP	BLOCK, THRUST (BLACK)	1 MODEL:02
20	45211-98503	SPRING	1 STD -MODEL:94 OPT MODEL:95-00
21	45211-98110	SPRING	2 MODEL:95-02
22	45112-98111	SHAFT, THRUST BLOCK	1 MODEL:95-02
23	09139-05031	SCREW (5X8)	1
24-1	09300-08005	BUSH	2
24-2	09306-08015	BUSH	2 MODEL:02
25	45110-98502	LEVER, RACK	1 STD -MODEL:94 OPT MODEL:95-00

**FIG.13**

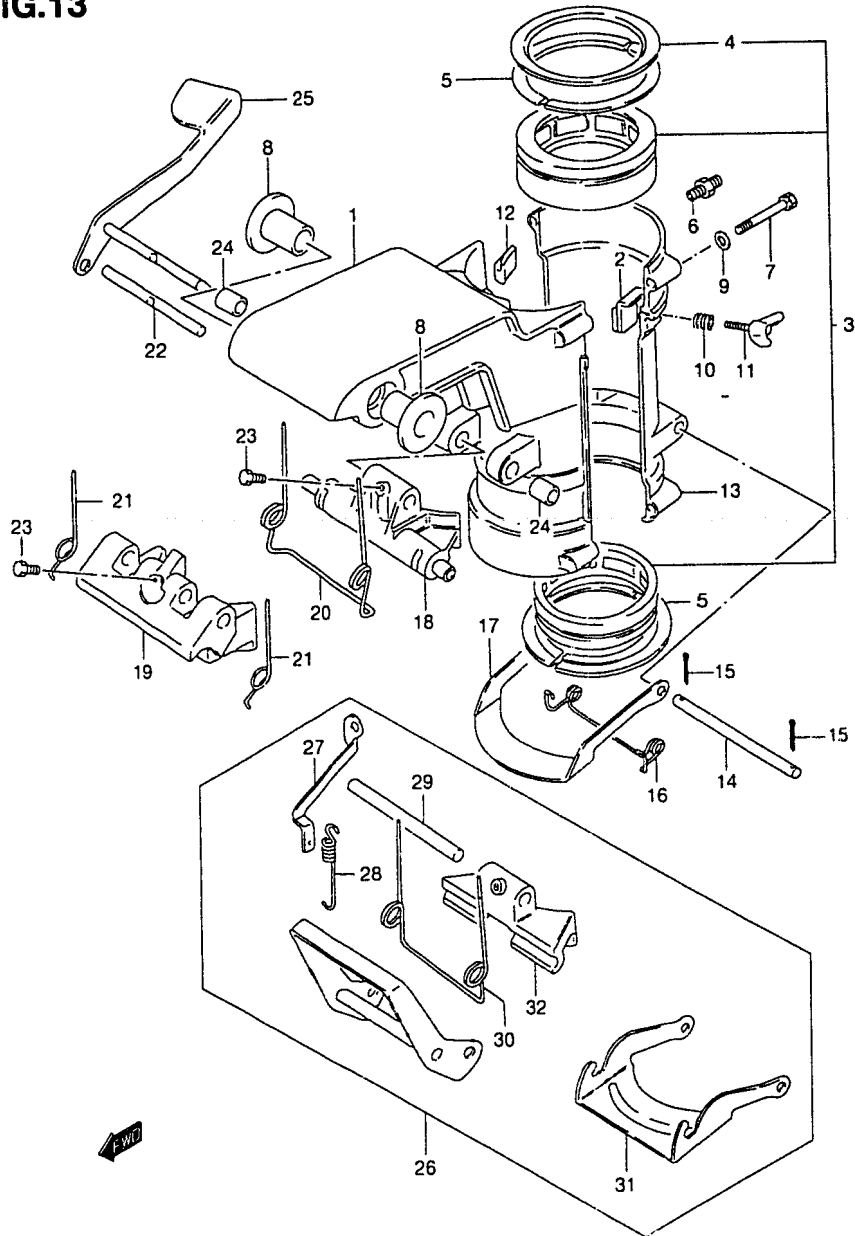
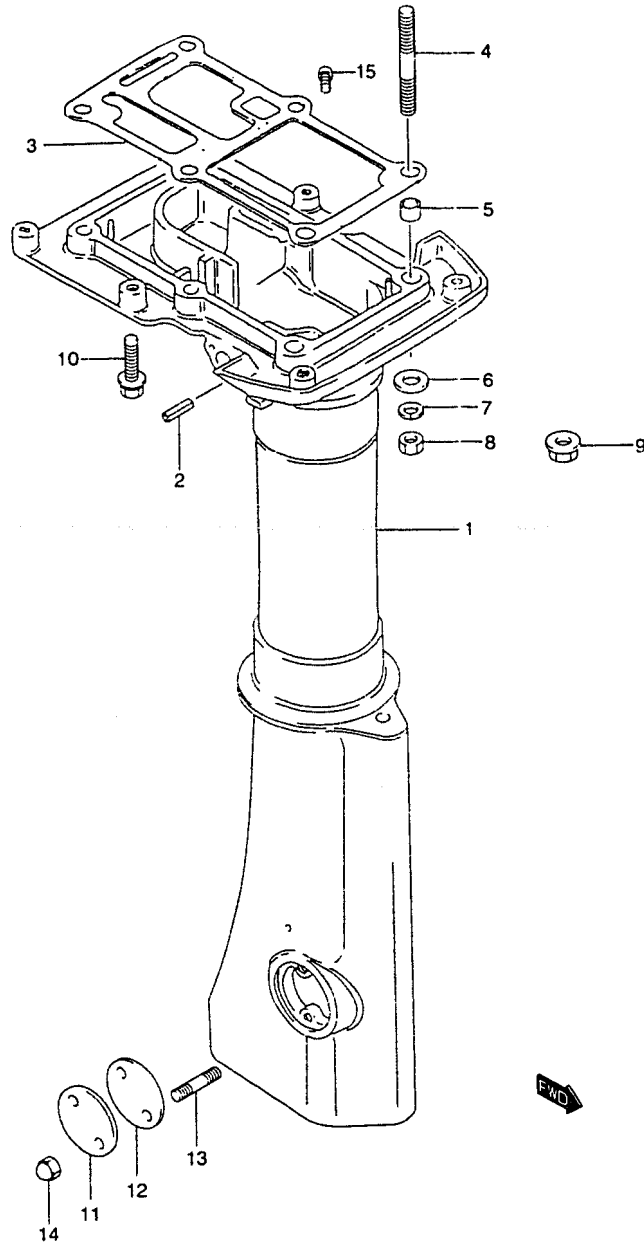

FIG.13 ( D-4) SWIVEL BRACKET

REF.NO.	PART NO.	DESCRIPTION	QTY.	REMARKS
26-1	45700-98501-0ED	SHALLOW DRIVE SET (GRAY)	1	OPT
26-2	45700-98501-0EP	SHALLOW DRIFE SET (BLACK)	1	MODEL:02
27	45713-98502	.HOOK	1	OPT
28	09443-06070	.SPRING	1	OPT
29	45112-98512	.SHAFT	1	OPT
30	45211-98100	.SPRING	1	OPT
31	45231-98111	.ARM	1	OPT
32-1	45411-98100-0ED	.BLOCK (GRAY)	1	OPT
32-2	45411-98100-0EP	.B		

FIG.14

FIG.14 ( D-5) DRIVESHAFT HOUSING



REF.NO.	PART NO.	DESCRIPTION	QTY.	REMARKS
1-1	52110-98515-02M	HOUSING, DRIVE SHAFT (S)	1	MODEL:86,-613765 →52110-98561-0ED USED WITH 52117-94400
1-2	52110-98561-0ED	HOUSING, DRIVE SHAFT (S)	1	MODEL:86-01 613766~
1-3	52110-98561-0EP	HOUSING, DRIVE SHAFT (S)	1	MODEL:02
1-4	52110-98526-02M	HOUSING, DRIVE SHAFT (L)	1	MODEL:86,-613765 52110-98571-0ED USED WITH 52117-94400
1-5	52110-98571-0ED	HOUSING, DRIVE SHAFT (L)	1	MODEL:86-01 613766~
1-6	52110-98571-0EP	HOUSING, DRIVE SHAFT (L)	1	MODEL:02
2	09205-10006	.PIN, CLUTCH LEVER	1	
3	52113-98510	GASKET	1	
4	09108-08147	STUD BOLT	2	
5	09206-11006	SPACER	2	
6	09160-08082	WASHER	2	MODEL:86-91
7	09162-08007	LOCK WASHER	2	MODEL:86-91
8	09140-08016	NUT	2	MODEL:86-91
9	09159-08104	NUT	2	MODEL:92-02
10	09118-08112	BOLT (8X30)	4	
11-1	52115-98501-0ED	COVER, CLUTCH ADJUSTING HOLE	1	
11-2	52115-98501-0EP	COVER, CLUTCH ADJUSTING HOLE	1	MODEL:02
12	52116-98510	GASKET, CLUTCH ADJUST HOLE	1	
13	09108-05011	STUD BOLT, CLUTCH ADJUST HOLE	2	
14	09145-05001	NUT	2	
15	52117-94400	TUBE, WATER INSP	1	613766~

COLOR : 02M (SILVER) 0ED (GRAY) 0EP (BLACK)

FIG.15

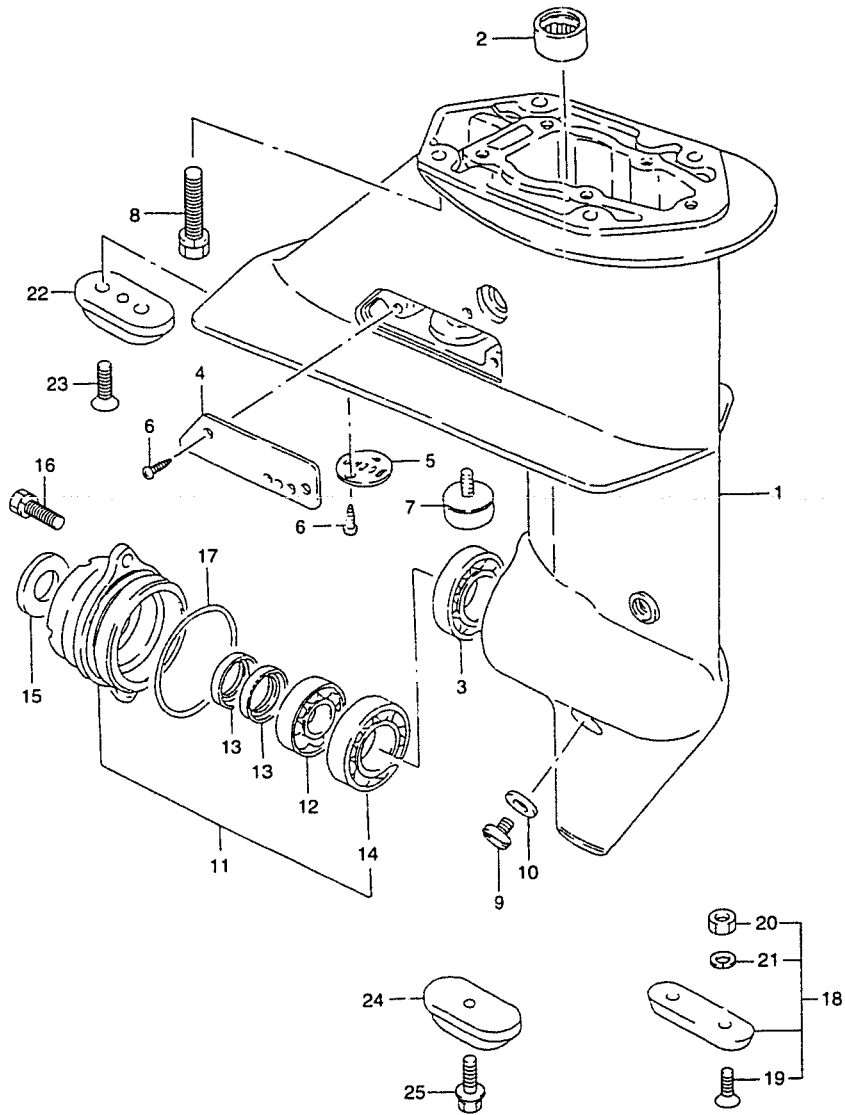

FIG.15 ( D-6) GEAR CASE

REF.NO.	PART NO.	DESCRIPTION	QTY.	REMARKS
1-1	55110-98541-0ED	CASE, GEAR	1	→55110-98551-0ED USED WITH 55112-98510-0ED, 41811-98500 AND 09116-06105
1-2	55110-98551-0ED	CASE, GEAR	1	MODEL:97-01
1-3	55110-98551-0EP	CASE, GEAR	1	MODEL:02
2	09263-14010	.BEARING	1	
3	09262-20106	.BEARING	1	
4-1	55112-98501-0ED	COVER, GEAR CASE SIDE	1	
4-2	55112-98510-0ED	COVER, GEAR CASE SIDE	1	MODEL:97-01
4-3	55112-98510-0EP	COVER, GEAR CASE SIDE	1	MODEL:02
5	55114-98502	COVER	1	
6	09132-04022	SCREW (4X10)	4	
7	11130-94600	ZINC, PROTECTION	1	
8	09117-08047	BOLT (8X30)	4	
9	09248-10008	PLUG, DRAIN	3	
10	09168-10022	GASKET	3	
11-1	56110-98520-0ED	HOUSING, PROP SHAFT BRG	1	
11-2	56110-98520-0EP	HOUSING, PROP SHAFT BRG	1	MODEL:02
12	09262-14001	.BEARING, PROP SHAFT	1	
13	09282-14002	.SEAL, PROP SHAFT OIL	2	
14	09262-20106	.BEARING, REVERSE GEAR	1	
15	56122-98500	PROTECTOR, HSG PROP	1	
16	09117-06031	BOLT (6X20)	2	
17	09280-48003	O RING (D:3.5 ID:47.7)	1	
18	55300-95500	ZINC ASSY	1	OPT
19	09126-06006	.SCREW (6X20)	2	OPT
20	09140-06020	.NUT	2	OPT
21	09162-06006	.LOCK WASHER	2	OPT
22	55321-93910	ZINC, PROTECTION	1	MODEL:89-94
23	09126-06008	SCREW (6X16)	1	MODEL:89-94
24	41811-98500	ZINC, PROTECTION	1	MODEL:95-02
25	09116-06105	BOLT (6X15)	1	MODEL:95-02

COLOR : 0ED (GRAY) 0EP (BLACK)



REF.NO.	PART NO.	DESCRIPTION	REMARKS
1-1	58111-96002-019	PROPELLER (3X8-1/2X7-1/8)	1 F700
1-2	58111-99100-019	PROPELLER (3X7-7/8X7-1/2)	1 F711
1-3	58111-99110-019	PROPELLER (3X7-7/8X6-3/4)	1 F611
1-4	58111-98722-019	PROPELLER (3X7-7/8X5-1/8)	1 F500
1-5	58111-99722-019	PROPELLER (3X7-7/8X5-7/8)	1 F600
2	58120-98513	BUSH	1
3	09209-05020	SHEAR PIN	1
4	58130-98101	NUT	1
5	09204-03003	COTTER PIN	2

FIG.16

COLOR : 019 (BLACK)

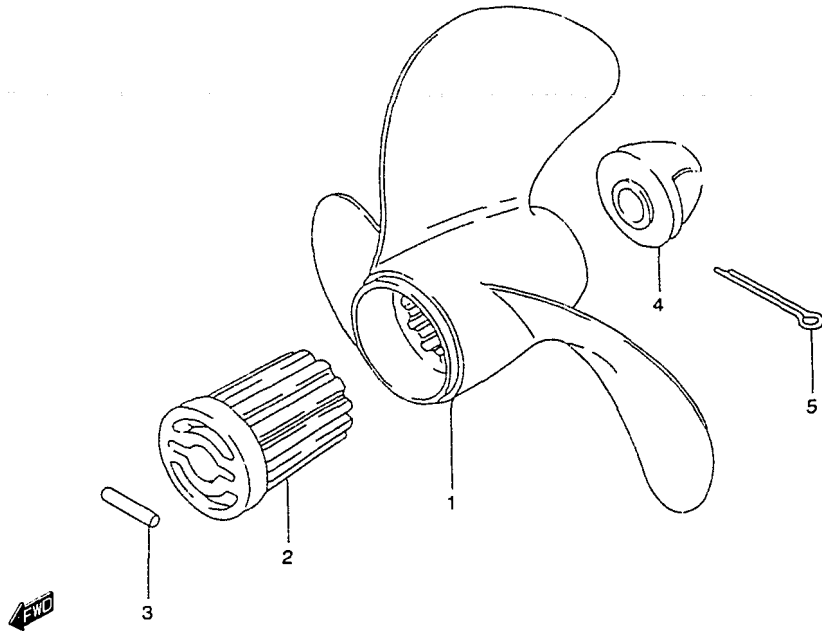
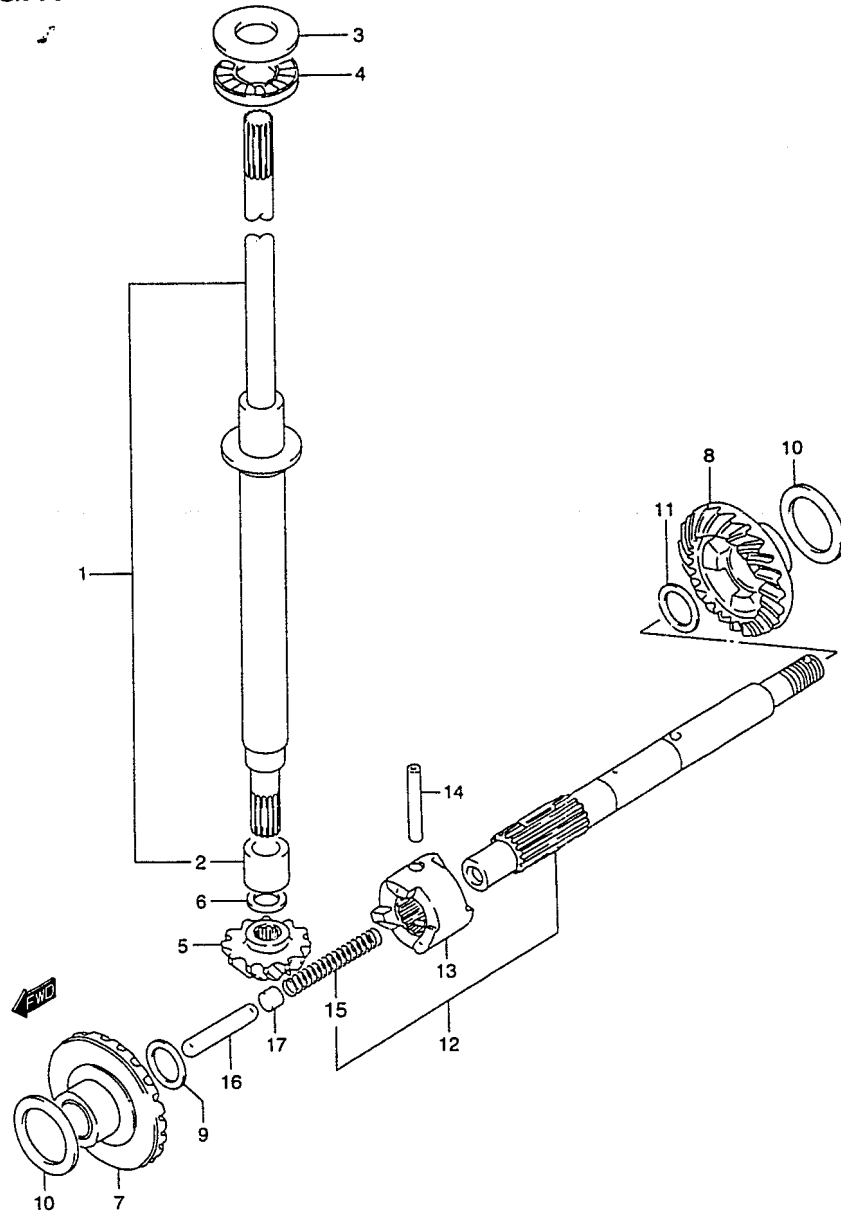

FIG.17



QTY.

REF.NO.	PART NO.	DESCRIPTION	REMARKS
1-1	57110-98551	SHAFT, DRIVE (S)	1
1-2	57110-98561	SHAFT, DRIVE (L)	1
2	57117-98501	.INNER RACE	1
3	09160-16023	THRUST WASHER	1
4	09263-15003	BEARING	1
5	57311-98511	PINION	1
6-1	09181-10104	SHIM (T:0.7)	1
6-2	09181-10106	SHIM (T:0.8)	1
6-3	09181-10108	SHIM (T:0.9)	1
6-4	09181-10111	SHIM (T:1.0)	1
6-5	09181-10116	SHIM (T:1.1)	1
6-6	09181-10120	SHIM (T:1.2)	1
6-7	09181-10125	SHIM (T:1.3)	1
7	57510-98502	GEAR, FORWARD	1
8	57521-98520	GEAR, REVERSE	1
9-1	09181-12102	THR WASHER FWD (T:0.5)	1
9-2	09181-12111	THR WASHER FWD (T:1.0)	1
10-1	09181-20026	SHIM (T:0.3)	2
10-2	09181-20027	SHIM (T:0.4)	2
10-3	09181-20186	SHIM (T:0.5)	2
10-4	09181-20187	SHIM (T:0.6)	2
10-5	09181-20010	SHIM (T:0.7)	2
10-6	09181-20188	SHIM (T:0.7)	2
10-7	09181-20190	SHIM (T:0.8)	2
11-1	09181-14106	THR WASHER REV (T:0.8)	1
11-2	09181-14111	THR WASHER REV (T:1.0)	1
11-3	09181-14128	THR WASHER REV (T:1.5)	1
11-4	08211-14183	THR WASHER REV (T:2.0)	1
12	57600-98511	SHAFT, PROPELLER	1
13	57621-98501	.SHIFTER, CLUTCH DOG	1
14	09209-04017	.PIN	1
15	09440-05019	.SPRING	1
16	57631-98500	ROD, PUSH	1
17	57632-98500	PIN, PUSH	1

MODEL:97-02

FIG.18

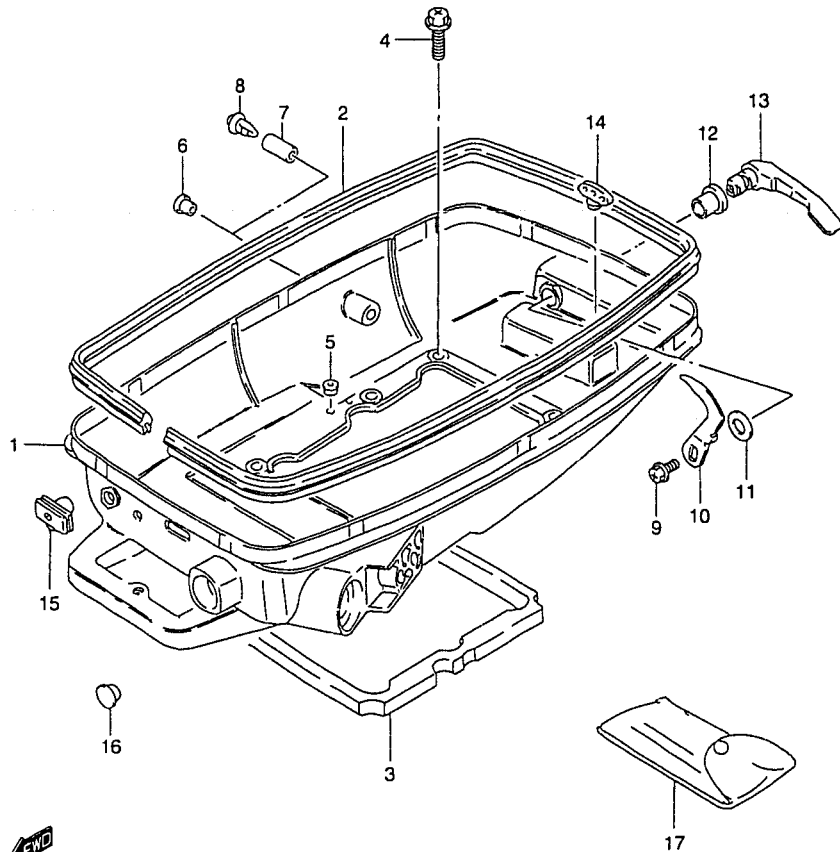

REF.NO.	PART NO.	DESCRIPTION	QTY.	REMARKS
1-1	61111-98121-0ED	COVER, ENGINE LOWER	1	MODEL:86~94
1-2	61111-98140-0ED	COVER, ENGINE LOWER	1	MODEL:95~01
1-3	61111-98140-0EP	COVER, ENGINE LOWER	1	MODEL:02
2	61112-98602	RUBBER, ENGINE LOWER	1	
3	61113-98500	SEAL	1	
4	02162-06207	BOLT (6X20)	6	
5	09250-08008	PLUG	1	INTERLOCK HOLE
6	09250-10001	PLUG	1	MODEL:86~91
7	09354-53103-600	HOSE, REMOCON SHAFT HOLE	1	MODEL:92~02 L:600→15
8	09409-06314-5PK	PLUG, REMCON SHAFT HOLE	1	MODEL:92~02
9	02162-06127	BOLT	1	
10	61631-98101	HOOK	1	
11	09164-13005	WASHER, WAVE	1	
12	09306-13007	BUSHING, HOOK LEVER	1	
13-1	61633-93930-0ED	LEVER, HOOK	1	
13-2	61633-93930-0EP	LEVER, HOOK	1	MODEL:02
14	61521-96000	HOLDER, SHEAR PIN	1	
15	37824-98100	GROMMET	1	OPT ~MODEL:92
16	09250-08016	CAP	1	RECOIL STARTER ROPE HOLE
17	09800-01001	TOOL SET	1	

COLOR : 0ED (GRAY) 0EP (BLACK)  
5PK (BLACK)

FIG.19

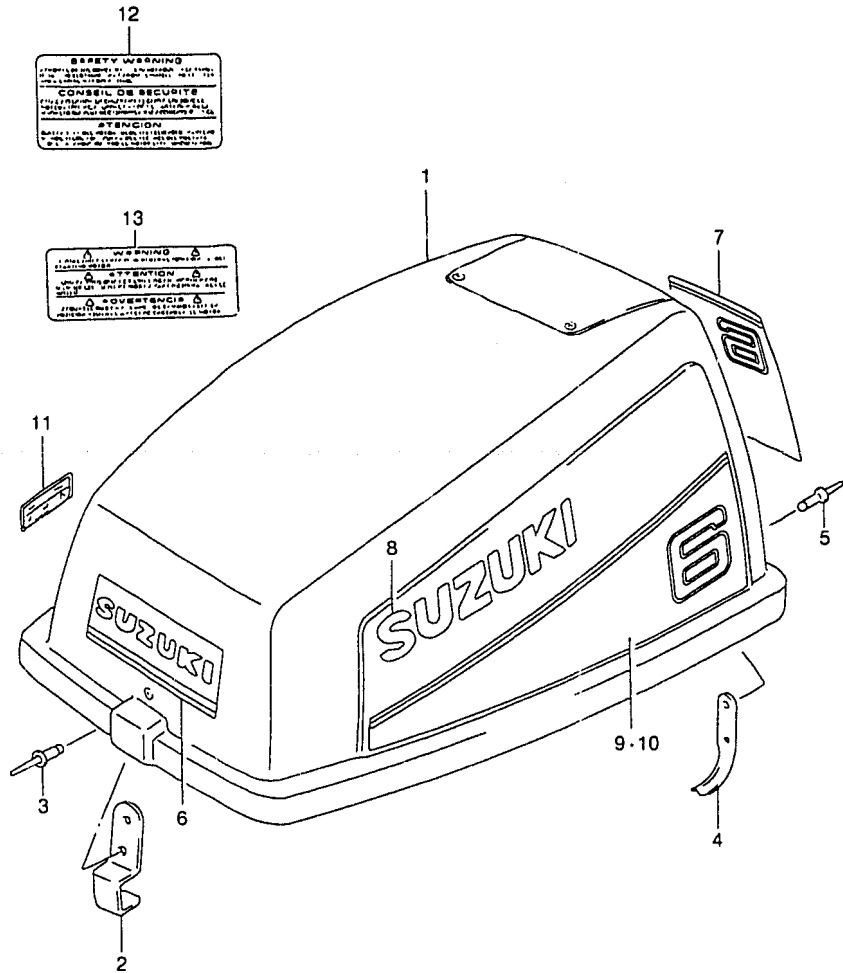

FIG.19 ( E-3) ENGINE COVER (MODEL:86-93)

REF.NO.	PART NO.	DESCRIPTION	QTY.	REMARKS
1	61410-98104-0ED	COVER SET, ENGINE	1	←61405-98862-0ED
2	61412-94300	HOOK, COVER	1	
3	09229-04018	RIVET, HOOK	2	
4	61611-93000	FASTENER, COVER	1	
5	09229-04007	RIVET, FASTENER	2	
6	61422-93960-70G	MARK, EMBLEM, FRONT	1	
8-1	68111-47C00-019	EMBLEM, SUZUKI	2	MODEL:86-88
8-2	61441-98620	EMBLEM, SUZUKI	2	MODEL:89-93
9	61443-99150-70G	DECAL, COVER,STBD	1	
10	61453-99150-70G	DECAL, COVER,PORT	1	
11	21131-96003	MARK, CLUTCH SHIFT	1	
12	61581-98610	MARK, SAFETY WARNING	1	
13	61582-98100	MARK, WARNING	1	

COLOR : 0ED (GRAY) 019(BLACK)  
70G (764/019) 764(GOLD)

REFER TO FIG.20 (E-4) FOR MODEL:94  
REFER TO FIG.21 (E-5) FOR MODEL:95-97  
REFER TO FIG.22 (E-6) FOR MODEL:98-01  
REFER TO FIG.23 (E-7) FOR MODEL:02

**FIG.20**

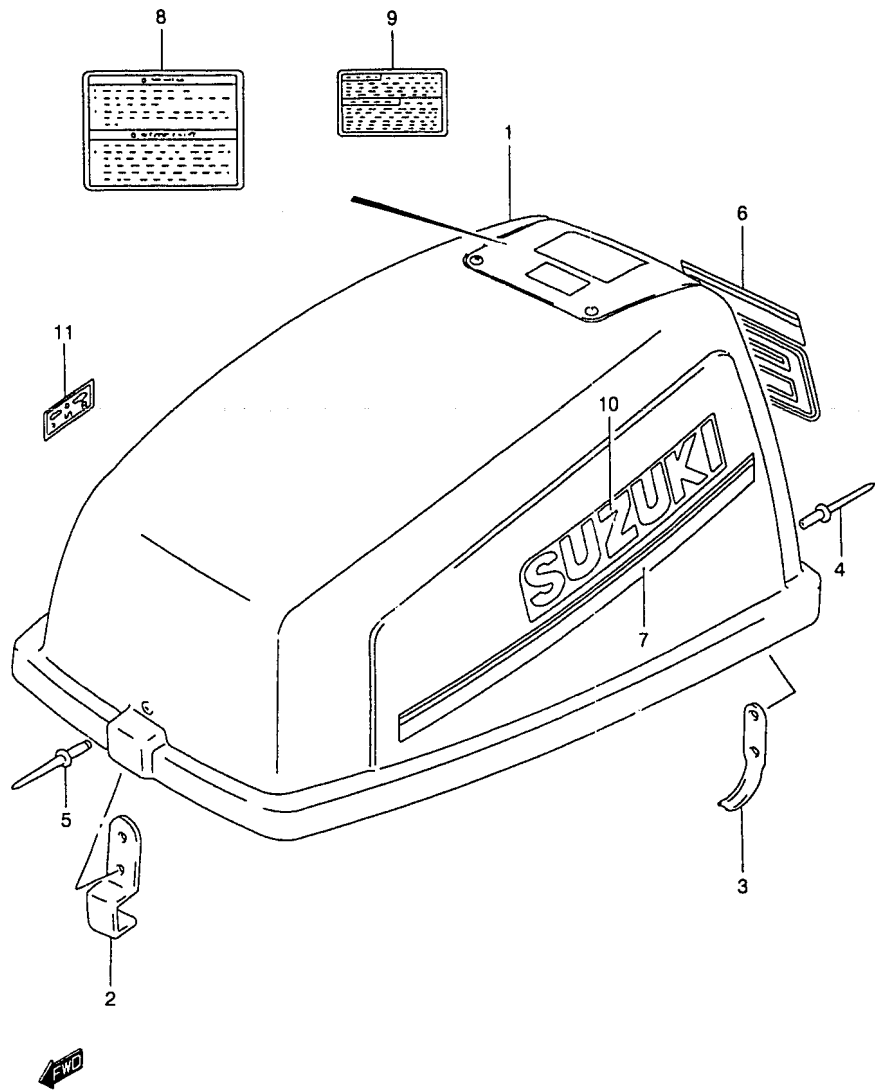

FIG.20 ( E- 4) ENGINE COVER (MODEL.94)

REF.NO.	PART NO.	DESCRIPTION	QTY.	REMARKS
1	61410-98841-0ED	COVER SET, ENGINE	1	
2	61412-94300	.HOOK, ENGINE COVER	1	
3	61611-93000	.FASTENER, ENGINE COVER	1	
4	09229-04007	.RIVET	2	
5	09229-04018	.RIVET	2	
6	61435-99180	.MARK, EMBLEM RR	1	
7	61440-98100	.STRIPE SET	1	
8	61581-98610	.MARK, SAFETY WARNING	1	
9	61582-98100	.MARK, WARNING	1	
10	68111-43400-1RR	.EMBLEM, SUZUKI	2	
11	21131-96003	.MARK, CLUTCH SHIFT	1	

COLOR : 0ED (GRAY)  
1RR (GOLD)

QTY.

FIG.21

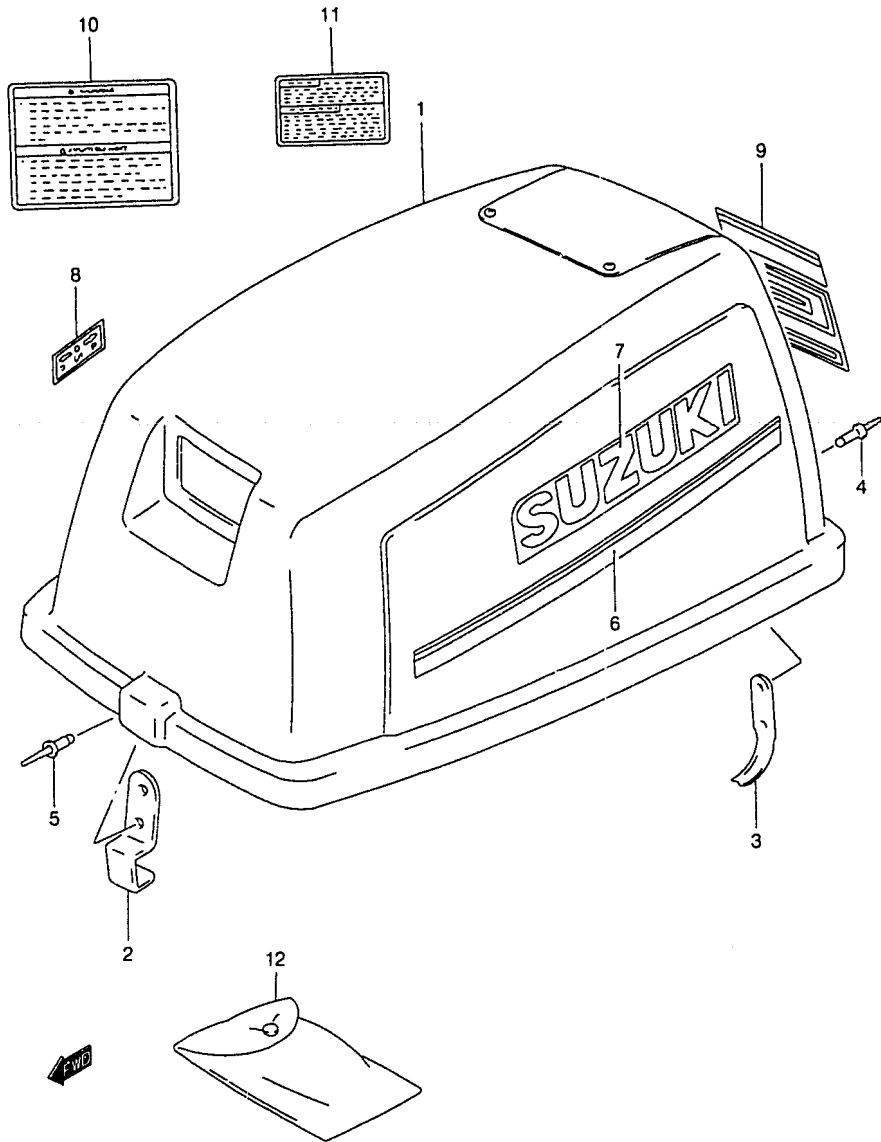

REF.NO.	PART NO.	DESCRIPTION	REMARKS
1	61410-98812-0ED	COVER SET, ENGINE	1
2	61412-94300	.HOOK, ENGINE COVER	1
3	61611-93000	.FASTENER, ENGINE COVER	1
4	09229-04007	.RIVET	2
5	09229-04018	.RIVET	2
6	61440-98100	.STRIPE SET	1
7	68111-43400-1RR	.EMBLEM, SUZUKI	2
8	21131-96003	.MARK, CLUTCH SHIFT	1
9	61435-99180	MARK, EMBLEM RR	1
10	61581-98610	MARK, SAFETY WARNING	1
11	61582-98100	MARK, WARNING	1
12	09800-01001	TOOL	1

COLOR : 0ED (GRAY)  
1RR (GOLD)

FIG.22

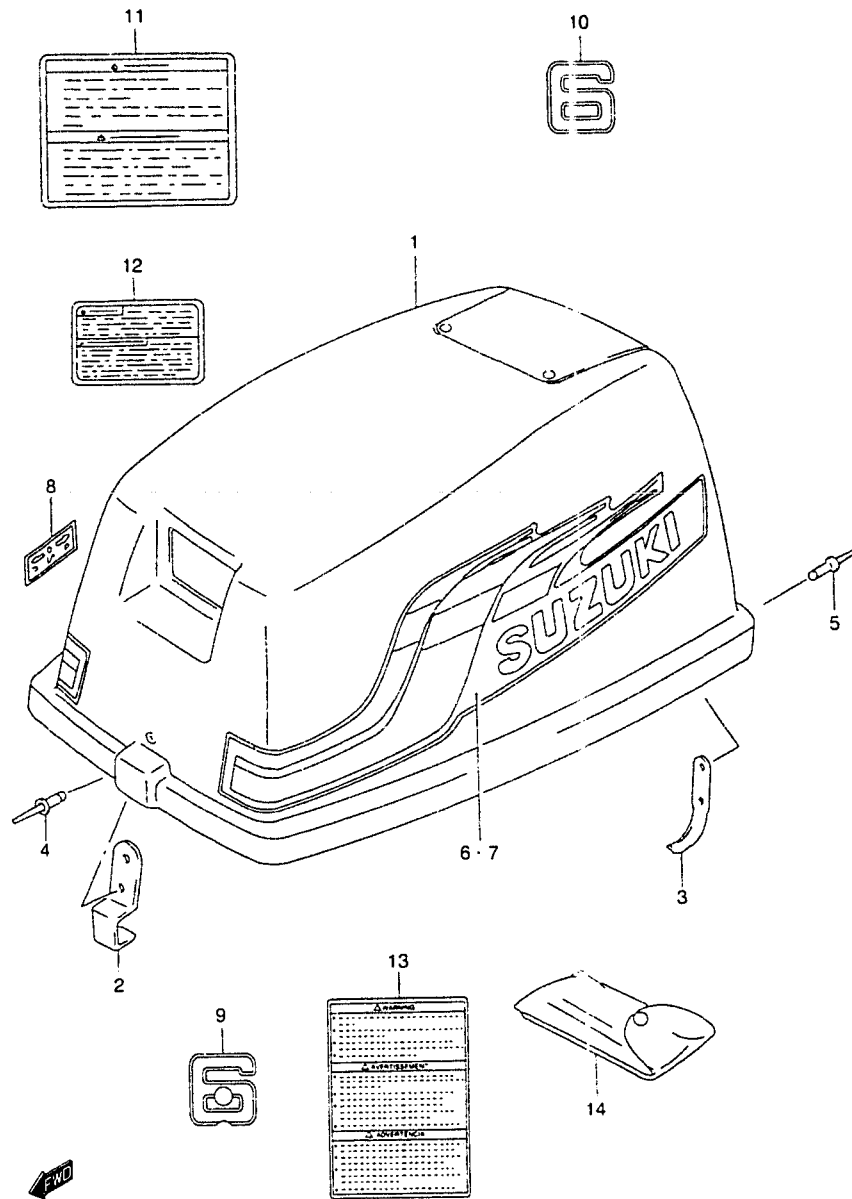

FIG.22 ( E-6)

ENGINE COVER (MODEL:98-01)

QTY.

REF.NO.	PART NO.	DESCRIPTION	REMARKS
1	61410-98800-0ED	COVER SET, ENGINE	1
2	61412-94300	.HOOK, ENGINE COVER	1
3	61611-93000	.FASTENER, ENGINE COVER	1
4	09229-04018	.RIVET	2
5	09229-04020	.RIVET	2
6	61443-981A0	.STRIPE, STBD	1
7	61453-981A0	.STRIPE, PORT	1
8	21131-96003	.MARK, CLUTCH SHIFT	1
9	61422-981B0	MARK, EMBLEM FRONT	1
10	61435-981B0	MARK, EMBLEM RR	1
11	61581-98610	MARK, SAFETY WARNING	1 -MODEL:00
12	61582-98100	MARK, WARNING	1 -MODEL:00
13	61581-98620	LABEL, ENGINE COVER	1 MODEL:01
14	09800-01001	TOOL	1

COLOR : 0ED (GRAY)

**FIG.23**

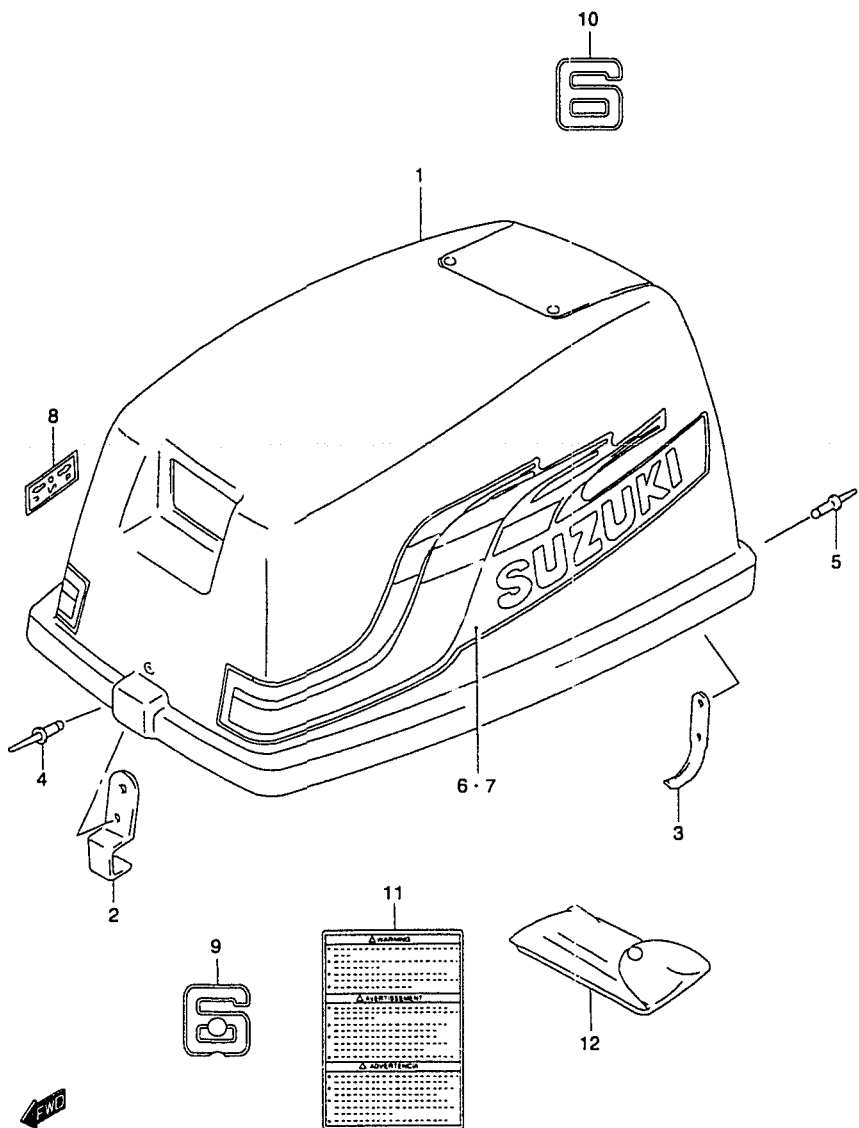

FIG.23 ( E-7) ENGINE COVER (MODEL:02)

REF.NO.	PART NO.	DESCRIPTION	QTY.	REMARKS
1	61400-98Y20-0EP	COVER SET, ENGINE (BLACK)	1	
2	61412-94300	.HOOK, ENGINE COVER	1	
3	61611-93000	.FASTENER, ENGINE COVER	1	
4	09229-04018	.RIVET	2	
5	09229-04020	.RIVET	2	
6	61443-981B0	.STRIPE, STBD	1	
7	61453-981B0	.STRIPE, PORT	1	
8	21131-96003	.MARK, CLUTCH SHIFT	1	
9	61422-981D0	MARK, EMBLEM FRONT	1	
10	61435-981D0	MARK, EMBLEM RR	1	
11	61581-98620	LABEL, ENGINE COVER	1	
12	09800-01001	TOOL	1	



FIG.24

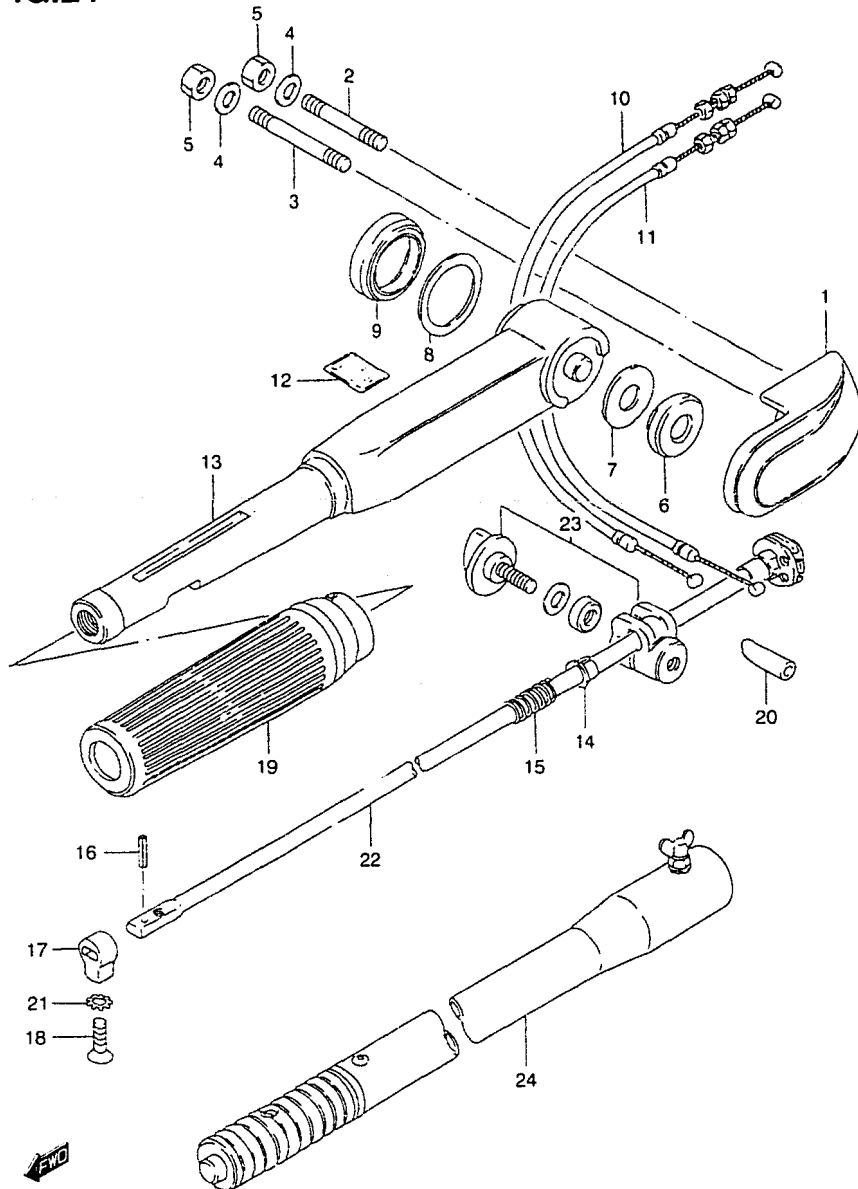

FIG.24 ( E- 8)

TILLER HANDLE (MODEL:89-92)

QTY.

REF.NO.	PART NO.	DESCRIPTION	REMARKS
1	63113-98100-0ED	COVER, TILLER HANDLE (GRAY)	1
2	01421-08507	STUD BOLT	1
3	01421-08607	STUD BOLT	1
4	08322-01087	WASHER	2
5	08310-00087	NUT	2
6	63115-98100	BUSHING	1
7	09160-13008	WASHER (13.5X31.5X0.5)	1
8	09160-32004	WASHER (32.5X42X0.5)	1
9	63116-98100	BUSHING, TILLER HANDLE	1
10	63610-98102	CABLE ASSY, THROTTLE NO.1	1
11	63610-98112	CABLE ASSY, THROTTLE NO.2	1
12	63215-93400	MARK, HANDLE GRIP	1
13	63100-98811-0ED	HANDLE, TILLER (GRAY)	1
14	63225-93200	BUSHING	1
15	09440-12027	SPRING	1
16	63227-93200	PIN	1
17	63223-92D00	STOPPER	1
18	09126-06006	SCREW	1
19	63210-94400	GRIP	1 →63210-93E30
20	63117-96301	COVER, STOP SWITCH	1
21	09163-06001	LOCK WASHER	1
22	63220-98504	ROD, HANDLE	1
23	63240-96300	ADJUSTER SET, HANDLE GRIP	1
24	63300-93900	BAR ASSY, EXTENTION	1 OPT, NOT FOR US MARKET

REFER TO FIG.25 (E- 9) FOR MODEL:93-02

FIG.25

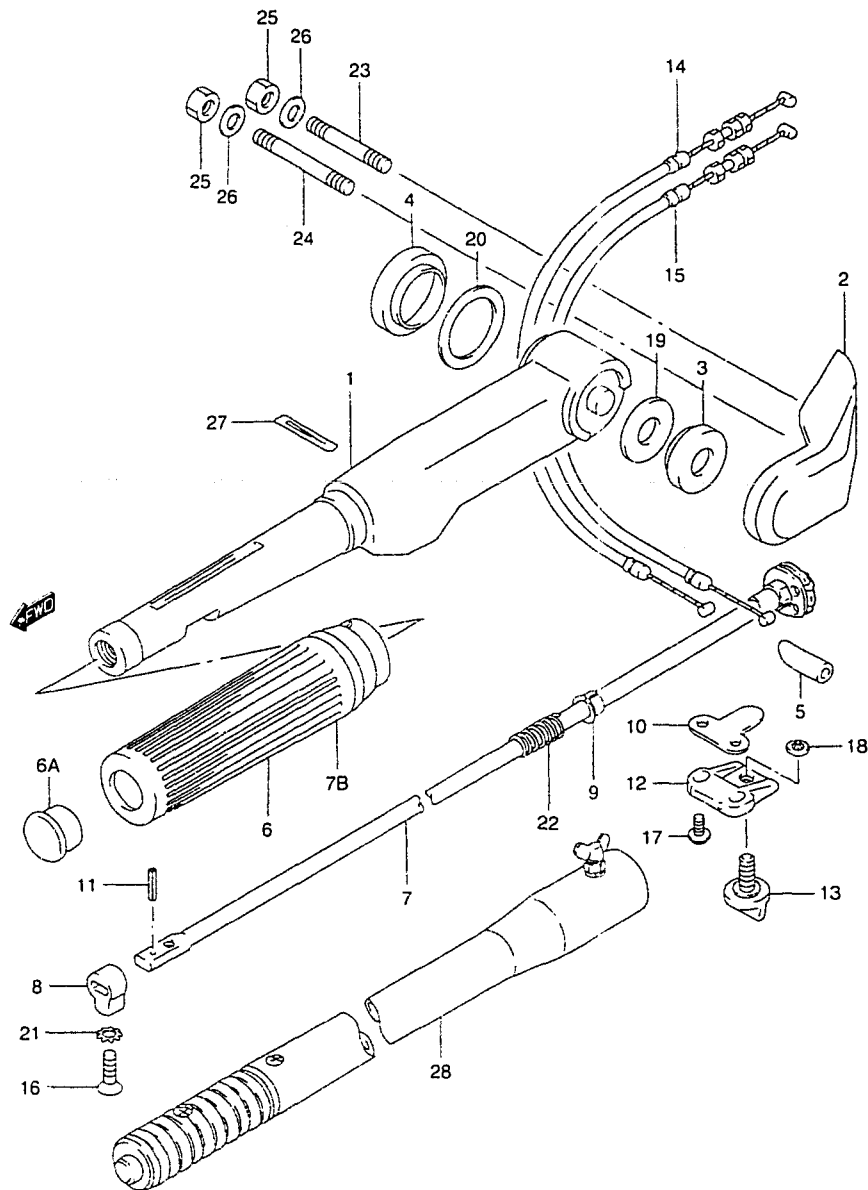

FIG.25 ( E-9)

TILLER HANDLE (MODEL:93-02)

QTY.

REF.NO.	PART NO.	DESCRIPTION	REMARKS
1-1	63111-98102-0ED	HANDLE, TILLER (GRAY)	1
1-2	63111-98102-0EP	HANDLE, TILLER (BLACK)	1 MODEL:02
2-1	63113-98100-0ED	COVER, TILLER HANDLE (GRAY)	1
2-2	63113-98120-0ED	COVER, TILLER HANDLE (GRAY)	1 MODEL:95-01
2-3	63113-98120-0EP	COVER, TILLER HANDLE (BLACK)	1 MODEL:02
3	63115-98100	BUSH, TILLER HANDLE COVER	1
4	63116-98100	BUSH, TILLER HANDLE	1
5	63117-96301	COVER, STOP SW WIRE	1 -MODEL:97
6	63210-94400	GRIP, HANDLE	1 →63210-93E30
6A	63213-94400	.CAP, STOP SW	1 -MODEL:98
7	63220-98504	ROD, HANDLE	1
7B	63210-93E30	GRIP	1 MODEL:96-02
8	63223-92D00	STOPPER, HANDLE ROD	1
9	63225-93200	BUSH, HANDLE ROD	1
10	63225-98601	PLATE, THROTTLE ADJ	1
11	63227-93200	PIN, HANDLE ROD	1
12-1	63241-98601	SUPPORT, HANDLE ROD	1
12-2	63241-986A0	SUPPORT, HANDLE ROD	1 MODEL:01,02
13-1	63244-98601	KNOB, THROTTLE ADJ	1
13-2	63244-986A0	KNOB, THROTTLE ADJ	1 MODEL:01,02
14	63610-98102	CABLE ASSY, THROTTLE NO.1	1
15	63610-98112	CABLE ASSY, THROTTLE NO.2	1
16	09126-06015	SCREW	1
17	09136-05041	SCREW, HANDLE ROD SPRT	2
18	09148-06008	NUT, THROTTLE ADJ KNOB	1
19	09160-13008	WASHER, TILLER HANDLE COVER	1
20	09160-32004	WASHER, TILLER HANDLE	1
21	09163-06001	WASHER, HANDLE GRIP SCREW	1
22	09440-12027	SPRING, HANDLE ROD	1

**FIG.25**

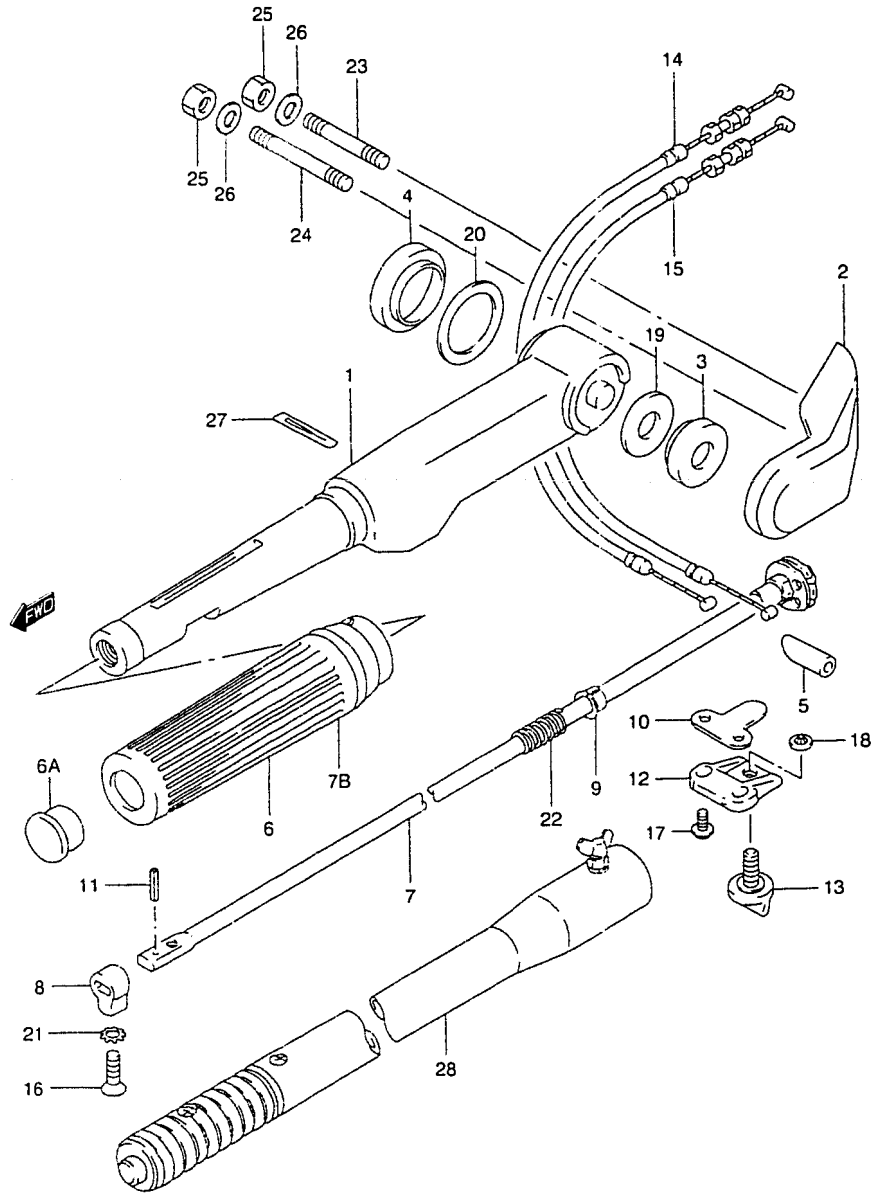

FIG.25 ( E-10)

TILLER HANDLE (MODEL:93-02)

QTY.

REF.NO.	PART NO.	DESCRIPTION	REMARKS
23	01421-08507	BOLT, HANDLE COVER STUD	1
24	01421-08607	BOLT, HANDLE COVER STUD	2
25	08310-00087	NUT, TILLER HANDLE	2
26	08322-01087	WASHER, TILLER HANDLE	2
27	63215-93110	MARK, HANDLE GRIP	1
28	63300-93E00	BAR ASSY, EXTENTION	1

OPT MODEL:96-02  
NOT FOR US MARKET

FIG.26

FIG.26 ( E-11)

FUEL TANK (MODEL:86,87)

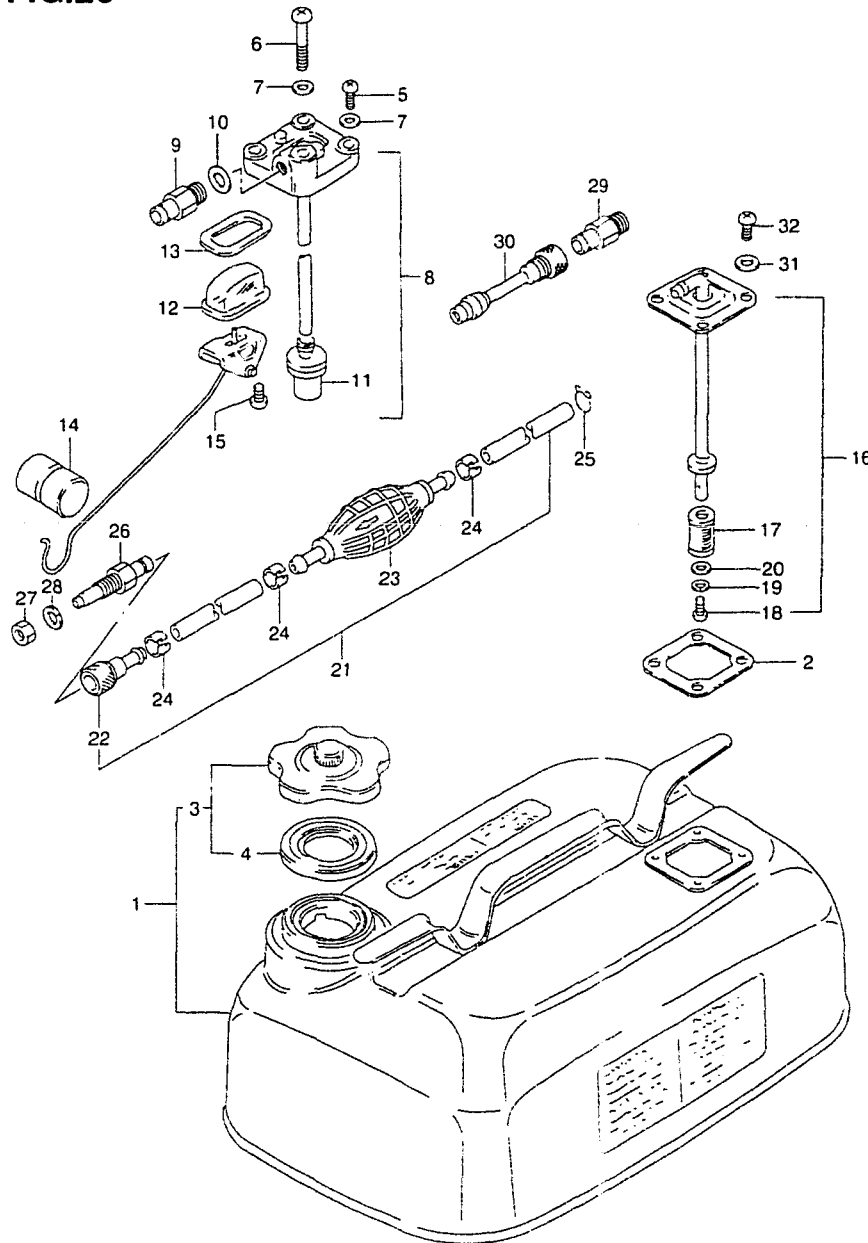

REF.NO.	PART NO.	DESCRIPTION	QTY.	REMARKS
1	65000-98500	TANK SET, FUEL (15L)	1	4 U.S GAL/3.3 IMP GAL →65800-92844 NOT FOR US MARKET
2	65871-93010	.GASKET	1	NOT FOR US MARKET
3	65510-92D00	.CAP	1	NOT FOR US MARKET
4	65561-98502	.GASKET	1	NOT FOR US MARKET
5	02112-06167	.SCREW	3	NOT FOR US MARKET
6	02112-06407	.SCREW	1	NOT FOR US MARKET
7	09168-06004	.WASHER	4	NOT FOR US MARKET
8	65850-98105	.GAUGE ASSY	1	NOT FOR US MARKET
9	65740-95500	..CONNECTOR, MALE FUEL	1	OD:13 NOT FOR US MARKET
10	09168-12001	..GASKET	1	NOT FOR US MARKET
11	65830-95500	..FILTER	1	NOT FOR US MARKET
12	65853-93001	..STRAINER	1	NOT FOR US MARKET
13	65854-93001	..GASKET, STRAINER	1	NOT FOR US MARKET
14	65864-95200	..FLOAT	1	NOT FOR US MARKET
15	09125-06063	..SCREW	2	NOT FOR US MARKET
16	65880-98500	OUTLET ASSY	1	NOT FOR US MARKET
17	65830-93301	.FILTER	1	NOT FOR US MARKET
18	09125-05050	.SCREW	1	NOT FOR US MARKET
19	08321-01057	.LOCK WASHER	1	NOT FOR US MARKET
20	08322-01057	.WASHER	1	NOT FOR US MARKET
21	65700-98522	HOSE (TANK - CONNECTOR)	1	
22	65750-98505	.CONNECTOR, FEMALE FUEL	1	ID:11
23	65770-99703	.PUMP, SQUEEZE	1	
24	65781-98500	.CLIP	3	
25	99401-11403	CLIP	1	
26	65720-98520	CONNECTOR, MALE FUEL	1	OD:11
27	08310-00107	NUT	1	
28	08321-01107	LOCK WASHER	1	
29	65720-98590	CONNECTOR, MALE FUEL	1	OPT OD:13
30	65700-95271	HOSE, FUEL JOINT	1	OPT OD:11/ID:13
31	09168-06004	WASHER	4	NOT FOR US MARKET
32	09125-06063	SCREW	4	NOT FOR US MARKET

REFER TO FIG.27 (E-12) FOR MODEL:88-00  
REFER TO FIG.28 (E-14) FOR PLASTIC:12L

FIG.27

FIG.27 ( E-12)

FUEL TANK (MODEL:88-00)

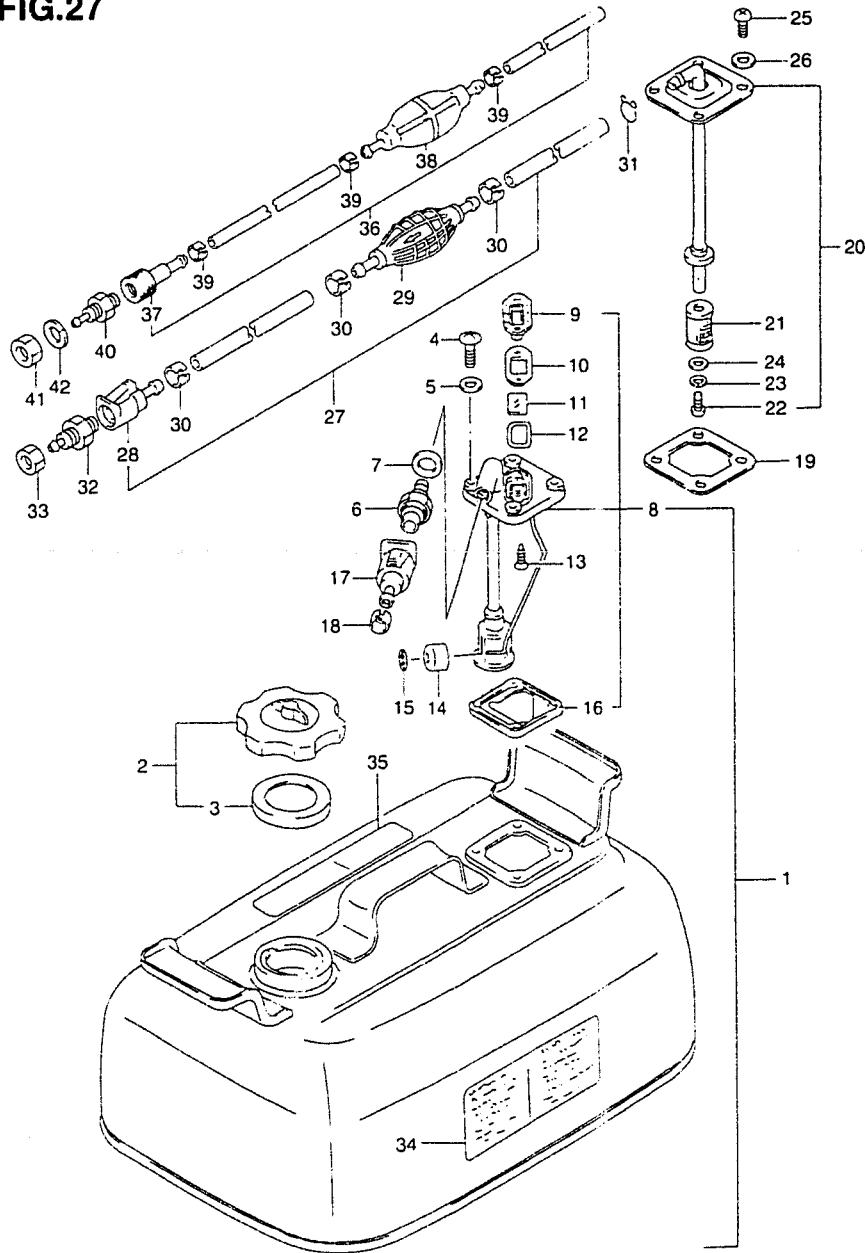

QTY.

REF.NO.	PART NO.	DESCRIPTION	QTY.	REMARKS
1	65800-92813	TANK SET, FUEL (15L)	1	4 U.S GAL/3.3 IMP GAL NOT FOR US MARKET
2	65510-92D00	.CAP ASSY, TANK	1	NOT FOR US MARKET
3	65561-92D00	..GASKET, TANK CAP	1	NOT FOR US MARKET
4	02142-06167	.SCREW	4	NOT FOR US MARKET
5	09168-06026	.WASHER	4	NOT FOR US MARKET
6-1	65720-94411	.CONNECTOR, FUEL	1	OD:13 NOT FOR US MARKET
6-2	65740-95500	.CONNECTOR, FUEL	1	231779- NOT FOR US MARKET
7	09168-12015	.GASKET, CONNECTOR	1	NOT FOR US MARKET
8	65850-92D51	.GAUGE ASSY, FUEL	1	NOT FOR US MARKET
9	65855-92D10	..COVER, GAUGE	1	NOT FOR US MARKET
10	65854-92D20	..GASKET	1	NOT FOR US MARKET
11	65853-92D00	..LENS	1	NOT FOR US MARKET
12	65854-92D30	..GASKET, LENS	1	NOT FOR US MARKET
13	03222-04083	..SCREW	2	NOT FOR US MARKET
14	65864-92D00	..FLOAT	1	NOT FOR US MARKET
15	65866-92D00	..NUT, PUSH	1	NOT FOR US MARKET
16	65871-92D00	..GASKET, FUEL	1	NOT FOR US MARKET
17	65750-94404	CONNECTOR, FUEL	1	OD:13 NOT FOR US MARKET
18	65781-98500	CLIP	1	NOT FOR US MARKET
19	65871-93010	GASKET, OUTLET	1	NOT FOR US MARKET
20	65880-98500	OUTLET ASSY	1	NOT FOR US MARKET
21	65830-93301	.FILTER	1	NOT FOR US MARKET
22	09125-05050	.SCREW (5X8)	1	NOT FOR US MARKET
23	08321-01057	.LOCK WASHER	1	NOT FOR US MARKET
24	08322-01057	.WASHER	1	NOT FOR US MARKET
25	02112-06107	SCREW (6X10)	4	NOT FOR US MARKET
26	09168-06026	WASHER	4	NOT FOR US MARKET
27	65700-98582	HOSE, FUEL	1	-MODEL:92 NOT FOR US MARKET
28	65750-94404	.CONNECTOR, FUEL	1	OD:13 NOT FOR US MARKET
29	65770-93903	.PUMP, SQUEEZE	1	NOT FOR US MARKET
30	65781-98500	.CLIP	3	NOT FOR US MARKET
31	09401-11403	CLIP	1	NOT FOR US MARKET

FIG.27

FIG.27 ( E-13) FUEL TANK (MODEL:88-00)

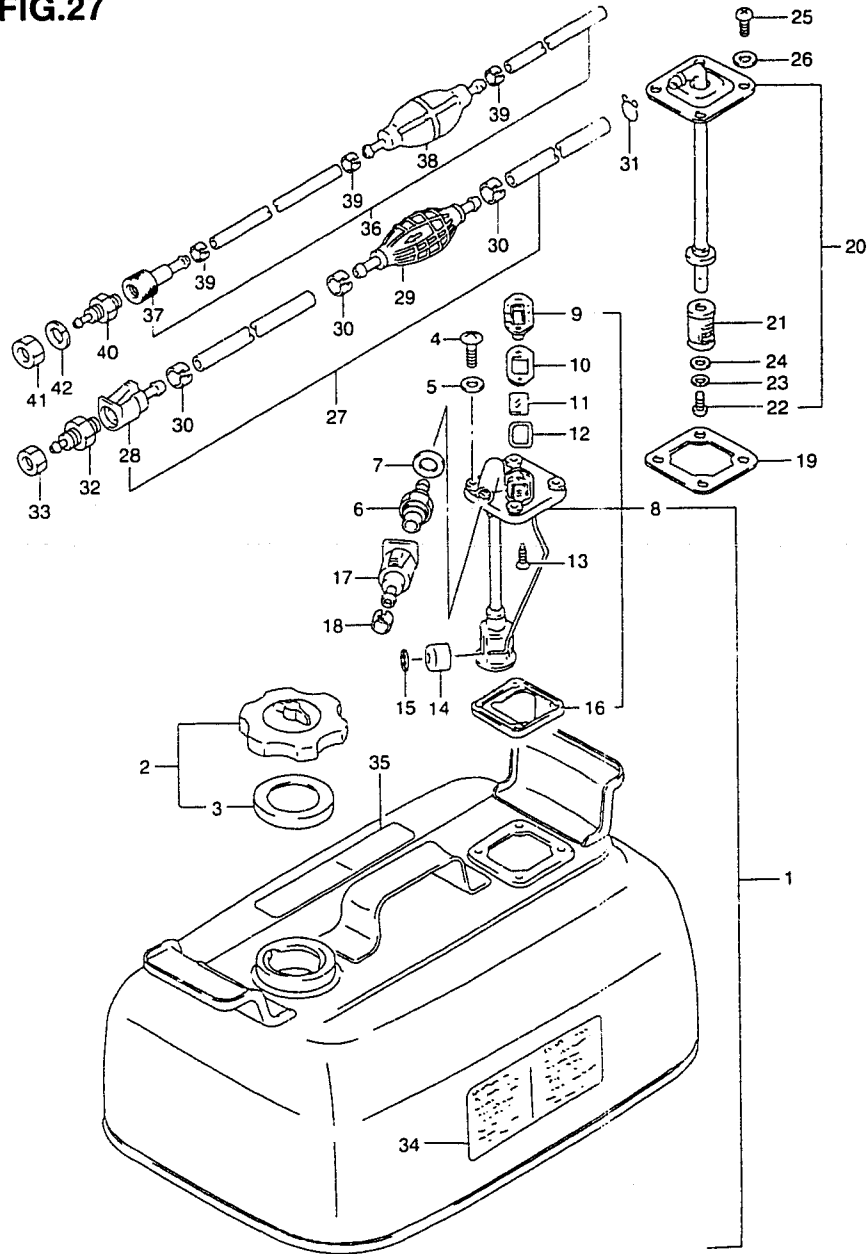

QTY.

REF.NO.	PART NO.	DESCRIPTION	QTY.	REMARKS
32	65720-94401	CONNECTOR, FUEL	1	-MODEL:92 NOT FOR US MARKET
33	08310-00107	NUT	1	NOT FOR US MARKET
34	65316-93331	MARK, FUEL CAUTION	1	NOT FOR US MARKET
35	65317-98520	MARK, FUEL CAPACITY	1	NOT FOR US MARKET
36	65700-98522	HOSE, FUEL	1	NOT FOR US MARKET
37	65750-98505	.SOCKET, FUEL HOSE	1	231779- NOT FOR US MARKET
38	65770-99703	.PUMP, SQUEEZE	1	231779- NOT FOR US MARKET
39	65781-98500	.CLIP	3	231779- NOT FOR US MARKET
40	65720-98520	PLUG, FUEL CONNECTOR	1	231779- NOT FOR US MARKET
41	09140-10032	NUT	1	231779- NOT FOR US MARKET
42	08321-01107	WASHER	1	NOT FOR US MARKET

FIG.28

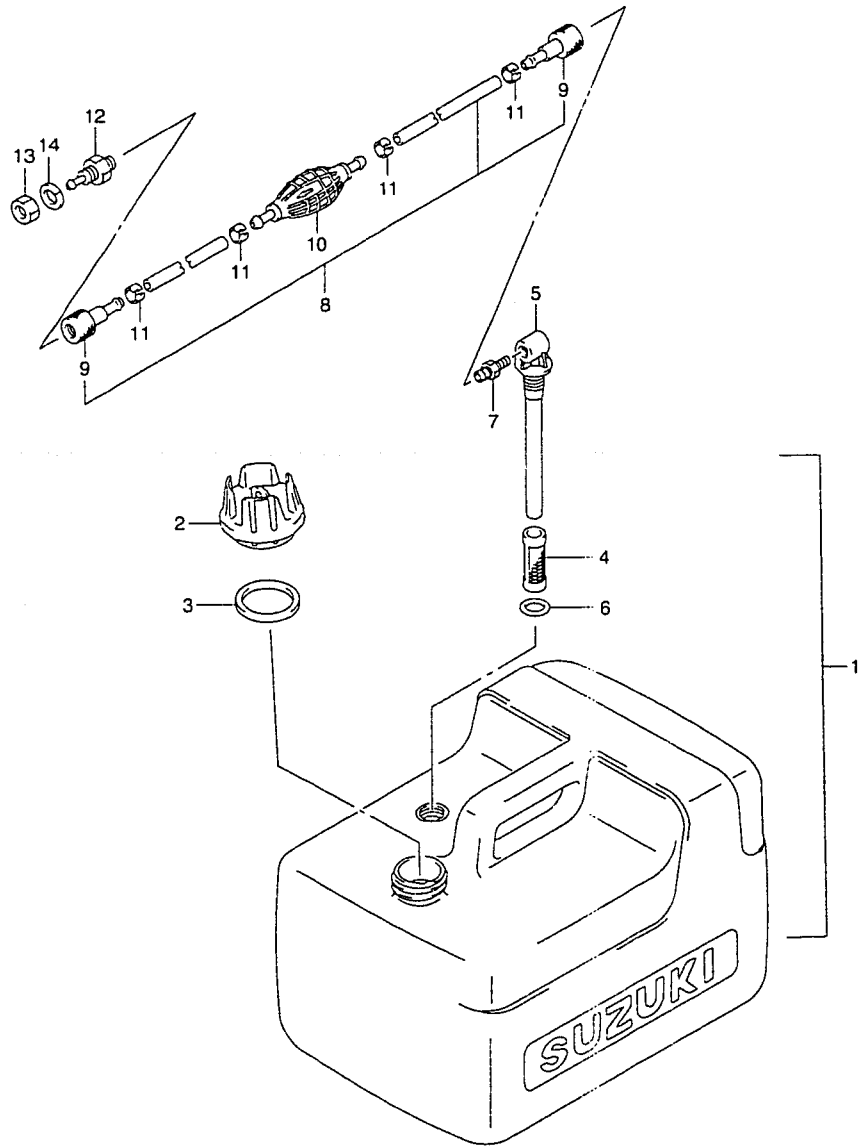

FIG.20 ( E-14) FUEL TANK (RESIN:12L)

REF.NO.	PART NO.	DESCRIPTION	QTY.	REMARKS
1	65000-99100	TANK ASSY, FUEL (12L)	1	
2	65520-99100	.CAP, FUEL TANK	1	
3	65561-95D00	.GASKET, TANK CAP	1	
4	65831-95D00	.FILTER, OUTLET	1	
5	65890-99100	.OUTLET ASSY	1	
6	65892-95D00	.O RING, FUEL OUTLET	1	
7	65740-99100	.PLUG, FUEL CONNECTOR	1	
8	65700-95D11	HOSE, FUEL	1	
9	65750-98505	.SOCKET, FUEL HOSE	2	
10	65770-99703	.PUMP, SQUEEZE	1	
11	65781-98500	.CLIP	4	
12	65720-98520	PLUG, FUEL	1	
13	09140-10032	NUT	1	
14	08321-01107	WASHER	1	

FIG.29

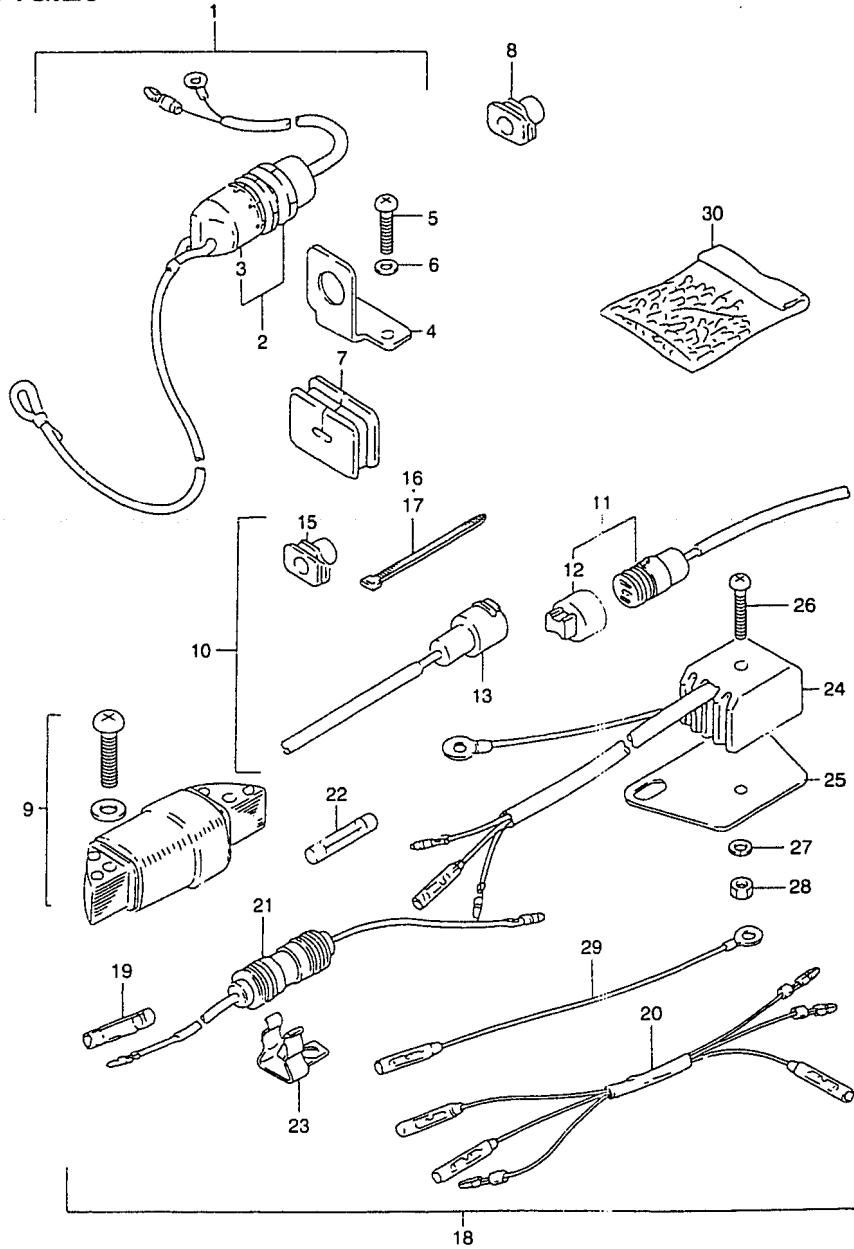

FIG.29 ( F-2)

OPTIONAL : ELECTRICAL

QTY.

REF.NO.	PART NO.	DESCRIPTION	QTY.	REMARKS
1	37802-98102	SWITCH SET, EMERGENCY	1	~MODEL:93
2	37830-89X50	.SWITCH ASSY, EMERGENCY	1	
3	37823-94400	.CAP	1	
4	37950-98501	.BRACKET	1	
5	02112-04163	.SCREW	2	
6	08321-01043	.LOCK WASHER	2	
7	37824-92D00	.GROMMET	1	
8	37824-98100	GROMMET	1	
9-1	32220-98110	COIL SET, LIGHTING	1	~MODEL:94
9-2	32200-99100	COIL SET, LIGHTING	1	MODEL:95-01
10	39600-93910	RECEPTACLE SET	1	
11	39601-95D00	.RECEPTACLE ASSY, LIGHTING	1	
12	36634-93910	.CAP	1	
13	39602-93900	.PLUG ASSY, LIGHTING	1	
15	39603-94400	.GROMMET	1	
16	09407-25402	.CLAMP	1	
17	09407-14403	.CLAMP	1	
18	32801-98102	RECTIFIER SET	1	
19	37132-93700	.CONNECTOR. LEAD WIRE	1	
20	32802-98100	.LEAD WIRE. RECTIFIER	1	
21	36740-95253	.CASE ASSY, FUSE	1	
22	09481-20001	.FUSE (20A)	1	
23	36791-95200	.HOLDER	1	
24	32800-95D01	.RECTIFIER ASSY	1	
25	32890-98100	.STAY	1	
26	02142-05257	.SCREW	1	
27	08321-01057	.LOCK WASHER	1	
28	08310-00057	.NUT	1	
29-1	36898-93300	.LEAD, CONSENT EARTH	1	MODEL:87,88
29-2	37801-98300	.LEAD, RECEPTACLE GROUND	1	MODEL:89-02
30	36990-87D00	TERMINAL & SLEEVE SET	1	



FIG.30

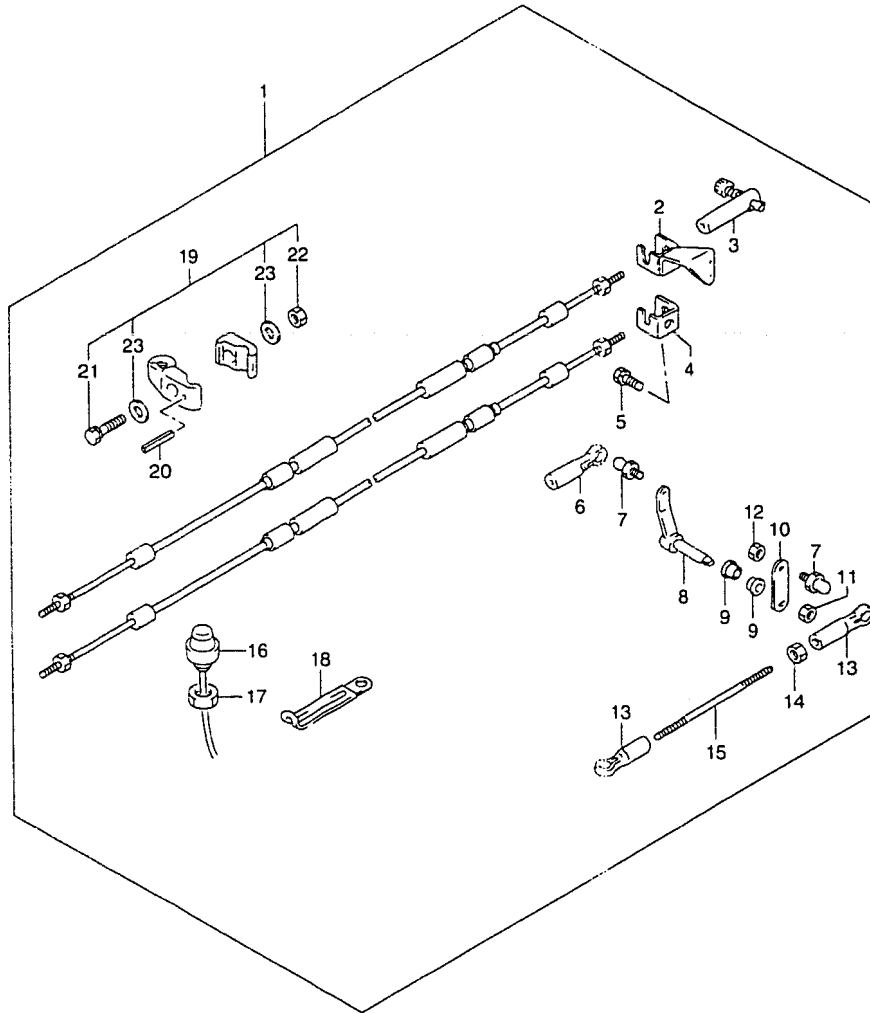

QTY.

REF.NO.	PART NO.	DESCRIPTION	REMARKS
1	67130-98810	REMOTE CONTROL PARTS SET	1
2	67340-98100	.HOLDER	1
3	67440-93701	.GUIDE	1
4	67341-93401	.HOLDER	1
5	09117-06040	.BOLT	3
6	67466-95200	.CONNECTOR	1
7	09119-06047	.BALL, PIVOT	3
8	67410-98101	.SHAFT	1
9	63225-93200	.BUSHING	2
10	67417-98100	.ARM	1
11	09159-08059	.NUT	1
12	09140-06020	.NUT	1
13	67463-95200	.CONNECTOR	2
14	09140-05005	.NUT	1
15	67413-98100	.ROD	1
16	37800-93714	.SWITCH ASSY, ENGINE STOP	1
17	09140-14030	.NUT	1
18	09404-06432	.CLAMP	1
19	19190-98110	.ARM SET	1
20	63227-93200	.PIN	1
21	09117-06039	..BOLT (6X25)	1
22	09140-06020	..NUT	1
23	09160-06055	..WASHER	2

FIG.31

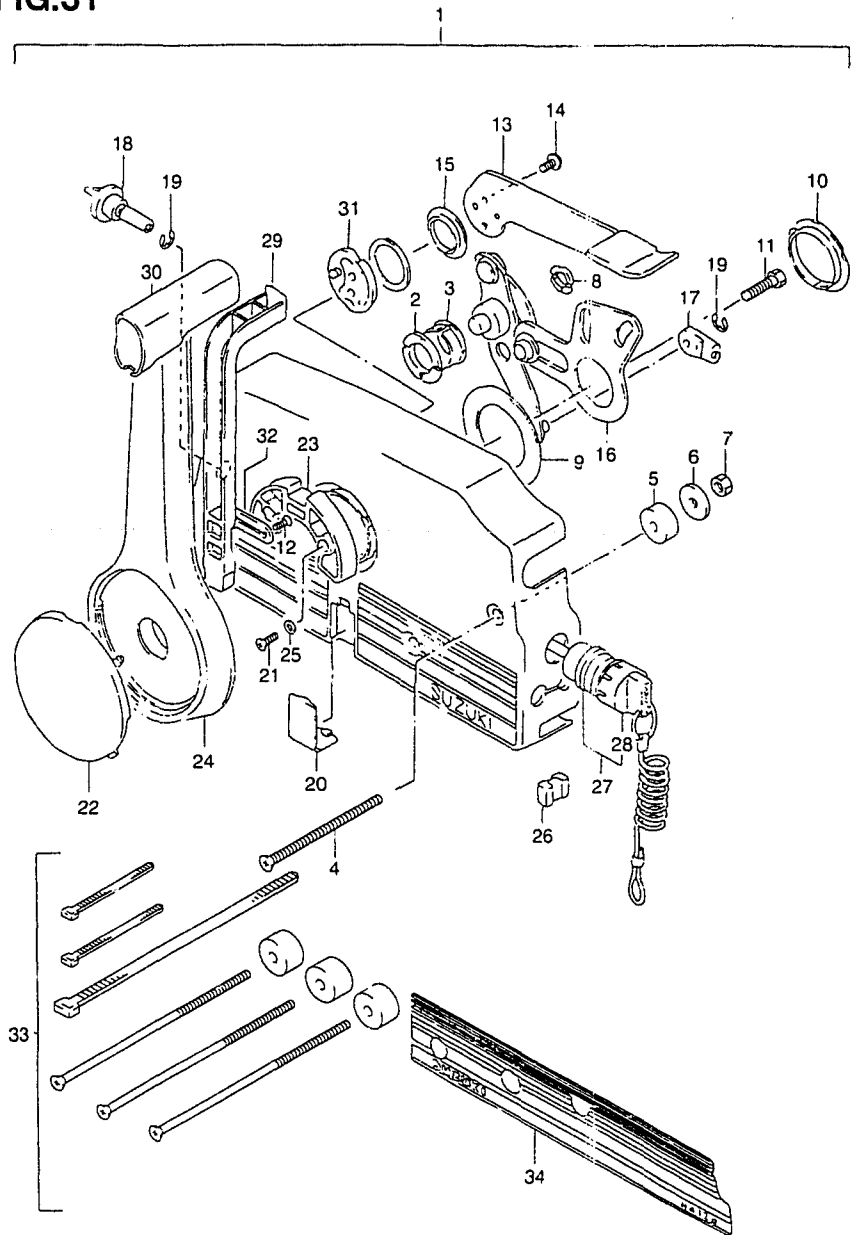

FIG.31 ( F- 4)

OPTIONAL : REMOTE CONTROL BOX (MODEL:89-92)

REF.NO.	PART NO.	DESCRIPTION	QTY.	REMARKS
1-1	67200-93951	BOX ASSY, REMOTE CONTROL	1	DECAL:BLUE →67200-93991-0ED
1-2	67200-93961-0ED	BOX ASSY, REMOTE CONTROL (GRAY)	1	DECAL:BLACK →67200-93991-0ED
2	67232-95600	.BUSH	1	
3	67232-95620	.BUSH	1	
4	67296-95600	.SCREW	3	
5	67294-95600	.SPACER	3	
6	09160-06104	.WASHER	3	
7	09140-06020	.NUT	3	
8	67232-95610	.BUSH	2	
9	67253-95600	.WASHER	1	
10	67252-95600	.BUSH	2	
11	09100-08232	.BOLT	1	
12	67296-94300	.SCREW	2	
13-1	67241-95600	.LEVER, FREE THROT (WHITE)	1	
13-2	67241-95680	.LEVER, FREE THROT (GRAY)	1	
14	09126-05003	.SCREW	2	
15	67243-95600	.BUSH	1	
16	67220-95620	.PLATE ASSY	1	
17	67275-95600	.END, CABLE	2	
18	67223-95600	.KNOB, BRAKE ADJ	1	
19	67292-94300	.E RING	3	
20-1	67267-95600	.COVER, WIRE (BLUE)	1	
20-2	67267-95610	.COVER, WIRE (BLACK)	1	
21	67296-95610	.SCREW	7	
22-1	67257-95600	.CAP, LEVER (BLUE)	1	
22-2	67257-95610	.CAP, LEVER (BLACK)	1	
23	67256-95600	.HOLDER, NEUT LOCK	1	

REFER TO FIG.32(F-6) FOR MODEL:93-02

FIG.31

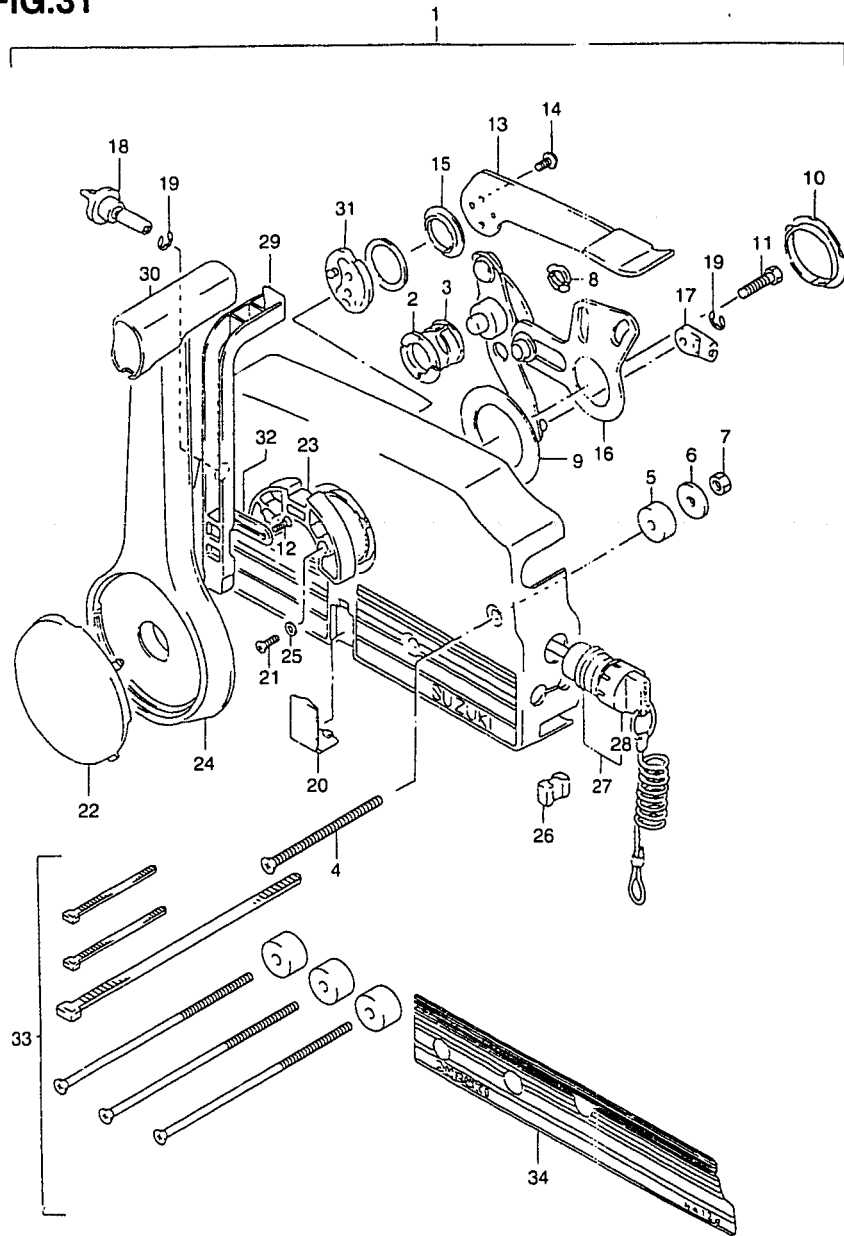

FIG.31 ( F-5)

OPTIONAL : REMOTE CONTROL BOX (MODEL:89-92)

REF.NO.	PART NO.	DESCRIPTION	REMARKS	QTY.
24-1	67251-95600	.LEVER, HANDLE (WHITE)		1
24-2	67251-95650	.LEVER, HANDLE (SILVER)		1
24-3	67251-95680	.LEVER, HANDLE (GRAY)		1
25	67297-95600	.WASHER		2
26	67273-95600	.SPACER		1
27	37820-94404	.SWITCH ASSY, EMERGENCY	→37820-92E00	1
28	37823-94400	.CAP & ROPE		1
29	67255-95600	.ARM, NEUTRAL LOCK		1
30	67261-95610	.GRIP		1
31	67245-95600	.DRUM ASSY, FREE THROTTLE		1
32	67258-87D00	.BRACKET, NEUTRAL ARM		1
33	67140-95600	ATTACHMENT, TWIN REMO-CON KIT		1
34	67282-95610	DECAL (BLACK)		1

FIG.32

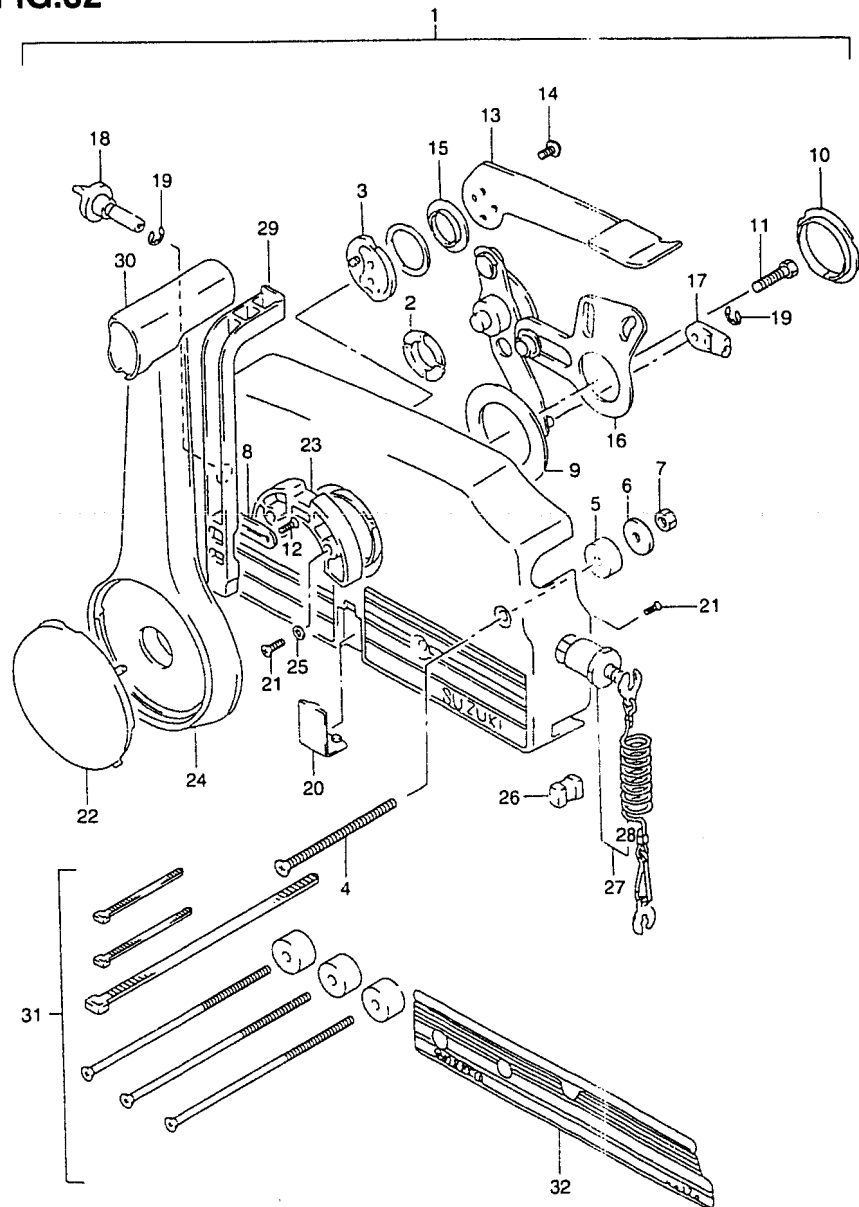

FIG.32 ( F-6)

OPTIONAL : REMOTE CONTROL BOX (MODEL:93-02)

REF.NO.	PART NO.	DESCRIPTION	QTY.	REMARKS
1-1	67200-93991-0ED	BOX ASSY, REMOCON (GRAY)	1	
1-2	67200-93991-0EP	BOX ASSY, REMOCON (BLACK)	1	MODEL:02
2	67232-95600	.BUSH	1	
3	67245-95600	.DRUM, FREE THROTTLE	1	
4	67296-95600	.SCREW	3	
5	67294-95600	.SPACER	3	
6	09160-06104	.WASHER	3	
7	09140-06020	.NUT	3	
8	67258-87D00	.BRACKET, NEUTRAL ARM	2	
9	67253-95600	.WASHER	1	
10	67252-95600	.BUSH	2	
11	09100-08232	.BOLT	1	
12	67296-94300	.SCREW	2	
13	67241-95680	.LEVER, FREE THROT (GRAY)	1	
14	09126-05003	.SCREW	2	
15	67243-95600	.BUSH	1	
16	67220-95620	.PLATE ASSY	1	
17	67275-95600	.END, CABLE	2	
18	67223-95600	.KNOB, BRAKE ADJ	1	
19	67292-94300	.E RING	3	
20	67267-95610	.COVER, WIRE (BLACK)	1	
21	67296-95610	.SCREW	7	
22	67257-95610	.CAP, LEVER (BLACK)	1	
23	67256-95600	.HOLDER, NEUT LOCK	1	
24	67251-95680	.LEVER, HANDLE (GRAY)	1	
25	67297-95600	.WASHER	2	
26	67273-95600	.SPACER	1	
27	37830-95D00	.SWITCH ASSY, EMERGENCY	1	
28	37823-92E00	.CAP & ROPE	1	
29	67255-95600	.ARM, NEUTRAL LOCK	1	
30	67261-95610	.GRIP	1	
31	67140-95600	ATTACHMENT, TWIN REMO-CON KIT	1	
32	67282-95610	DECAL (BLACK)	1	OPT

**FIG.33**

QTY.

REF.NO.	PART NO.	DESCRIPTION	REMARKS
1	11410-98811	GASKET SET	1
2	11141-98130	.GASKET, CYLINDER HEAD	1
3	11413-98510	.GASKET, UPPER, OIL SEAL	1
4	11433-98510	.GASKET, UNDER, OIL SEAL	1
5	13121-98120	.GASKET, INLET CASE	1
6	13122-98110	.GASKET, REED VALVE SEAT	1
7	13125-98110	.GASKET, CARBURETOR	1 ID:25
8	13125-98310	.GASKET, CARBURETOR	1 ID:19
9	14151-98111	.GASKET, EXHAUST COVER	2
10	17472-98503	.GASKET, PUMP PANEL	1
11	52113-98510	.GASKET, DRIVE SHAFT HOUSING	1
12	52116-98510	.GASKET, CLUTCH ADJUST HOLE	1
13	56132-98510	.GASKET, DRIVE SHAFT BRG HOUSING	1
14	09168-06004	.GASKET, SHIFT CAM SCREW	1 6X11.8X1.5
15	09168-10022	.GASKET, DRAIN PLUG	3 10X17X1.5

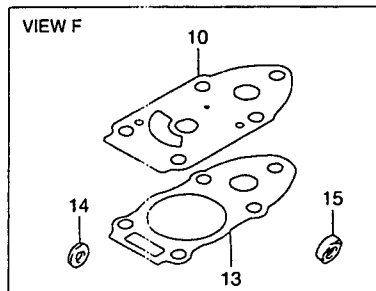
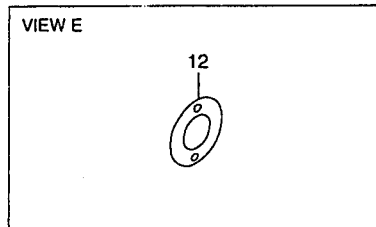
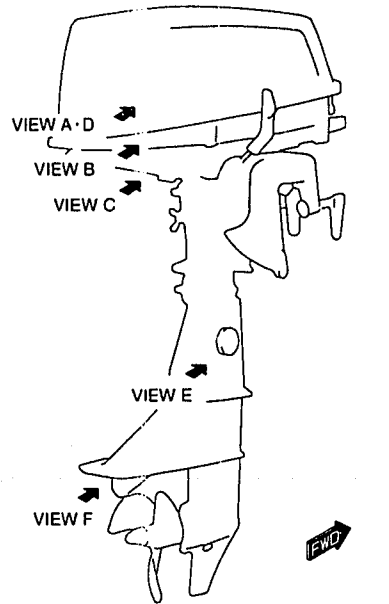
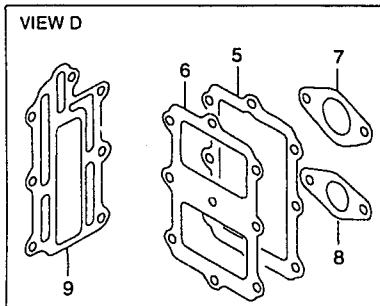
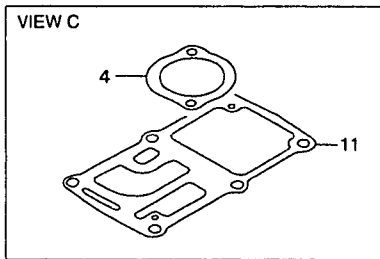
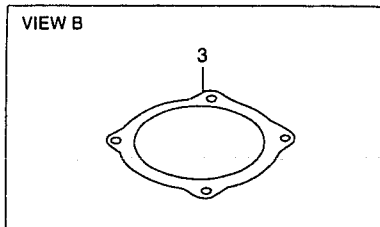
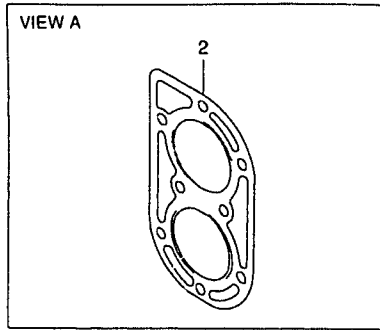
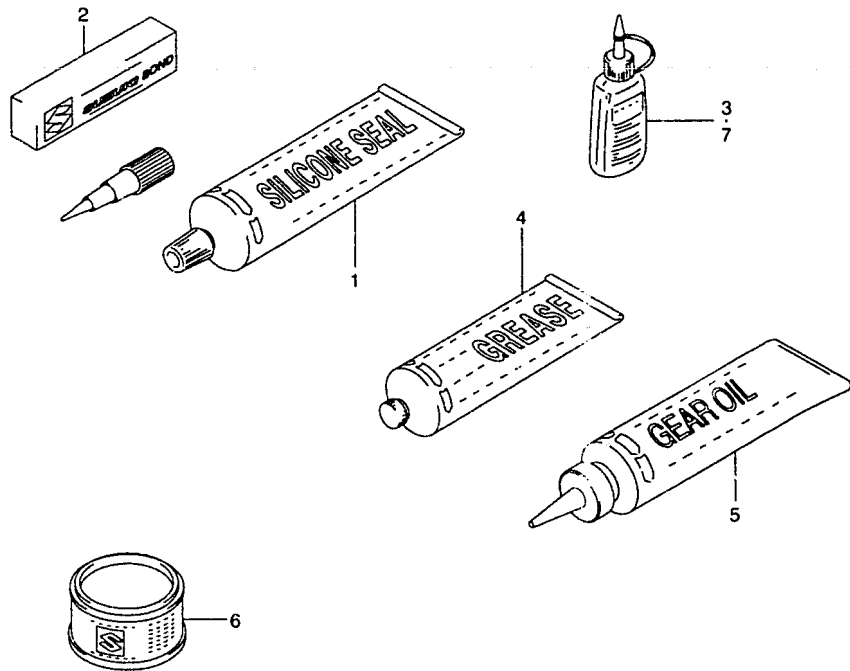

FIG.34



REF.NO.	PART NO.	DESCRIPTION	QTY.	REMARKS
1	99000-31120	SUZUKI SILICONE SEAL	1	FOR GEAR CASE 50G
2	99104-31140	GASKET, LIQUID	1	FOR GEAR CASE 100G
3	99000-32020	THREAD LOCK SUPER "1333B"	1	50G
4	99000-25160	GREASE, WATER RESISTANT	1	250G
5	99000-22540	GEAR OIL, OUTBOARD MOTOR	1	400CC NOT FOR US MARKET
6	99000-25010	SUZUKI SUPER GREASE A	1	450G, FOR CRANK OIL SEAL
7	99000-32050	THREAD LOCK "1342"	1	50G
8-1	99011-98532-03A	MANUAL, OWNER'S	1	MODEL:89 DRAWING NOT SHOWN
8-2	99011-98533-03A	MANUAL, OWNER'S	1	MODEL:90
8-3	99011-98534-03A	MANUAL, OWNER'S	1	MODEL:91
8-4	99011-98535-03A	MANUAL, OWNER'S	1	MODEL:92
8-5	99011-98536-03A	MANUAL, OWNER'S	1	MODEL:93
8-6	99011-98537-03A	MANUAL, OWNER'S	1	MODEL:94
8-7	99011-98538-03A	MANUAL, OWNER'S	1	MODEL:95
8-8	99011-98550-03A	MANUAL, OWNER'S	1	MODEL:96
8-9	99011-98552-03A	MANUAL, OWNER'S	1	MODEL:97
8-10	99011-98553-03A	MANUAL, OWNER'S	1	MODEL:98
8-11	99011-98554-03A	MANUAL, OWNER'S	1	MODEL:99,00
8-12	99011-98555-03A	MANUAL, OWNER'S	1	MODEL:01,02