



Parts Book

DT 4 (1978)

DT 4.5 (1977)



1703 Hwy 35 So., Laurence Harbor, NJ 08879

(732) 264-7176

(800) 338-0645 FAX (732) 264-2472

www.brownspoint.com

PREFACE

This parts catalogue has been arranged to include all prior modification as the final edition.

No revised edition will be issued any more and be sure to make use of this in good keeping.

Upon receipt of this final edition, the old catalogue should be thrown away.

This parts catalogue covers the list of all service parts for SUZUKI DT2~DT9 (C, D, F).

A. INSTRUCTIONS FOR QUOTING THE CATALOGUE

1. DIMENSIONS

Dimensions of the parts in this catalogue are indicated in unit millimeters.

2. ABBREVIATIONS

Abbreviations used in this catalogue are as follows:

AR	: As required	NT	: Number of teeth
ASSY	: Assembly	OPT	: Optional
E.No.	: Engine Number	OS	: Over Size
F.No.	: Frame Number	STD	: Standard
d	: Diameter of material	T	: Thickness
ID	: Inside diameter	US	: Under size
OD	: Outside diameter	W	: Width
L	: Length	S,L,UL,LL	: Transom type

LH : Left hand side

RH : Right hand side

~100045 : Up to F.No.-100045

100046~ : From F.No.-100046

12 x 34 x 5.6 Figures in the description column show the dimensions of parts.

| | |
ID OD T(or W,L)

To 12340-56781 (Parts No.) : indicates that the parts number was changed to 12345-56781 and the new parts are interchangeable with the former ones but the former ones are not interchangeable with new ones.

From 12345-56781 (Parts No.) : indicates that the former and new parts are interchangeable with each other and both are usable.

The number of letter shown below Q'ty indicate the MODEL NAME as shown right side.

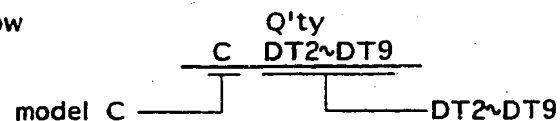

3. INNER PARTS OF ASSEMBLY

Parts number that have a period (.) mark in front of the part description on a text page are separately serviced parts of the assembly.

4. MODIFICATION NOTICE

A parts bulletin will be sent to you on all occasions when changes in parts occur, including interchangeable modifications between new parts and old ones.

5. NOTE

5-1. There are some different parts from those of production models among spare parts for the administrative reasons and common use of them with other models.

5-2. In respect of rubber hoses and vinyl tubes, please be sure to use them by cutting off according to the length mentioned on parts catalogue or what is actually required on the vehicle.

5-3. Note that the drawings on the illustration page are for ready reference of spare parts number, not to be used as an assembly manual.
When assembling, use "SUZUKI SERVICE MANUAL".

6. SPECIFICATION CODE

This catalogue contains the parts for the model designed for the following spec.;

spec. code: DT2C (E1, E28), DT2D (E1), DT2F (E1), DT3.5F (E1, E16),
DT4.5C (E1, E28), DT4D (E1), DT5D (E1, E3, E13),
DT5F (E1, E3, E13)
DT7.5C (E1, E13, E28), DT7.5D (E1, E13),
DT7.5F (E1, E9, E13)
DT9C (E1, E13, E28, E37), DT9D (E1, E13),
DT9F (E1, E9, E13)

7. SERIAL FRAME NUMBER

C-10001~, D-10001~, F-10001~

FIG.31

E - 3

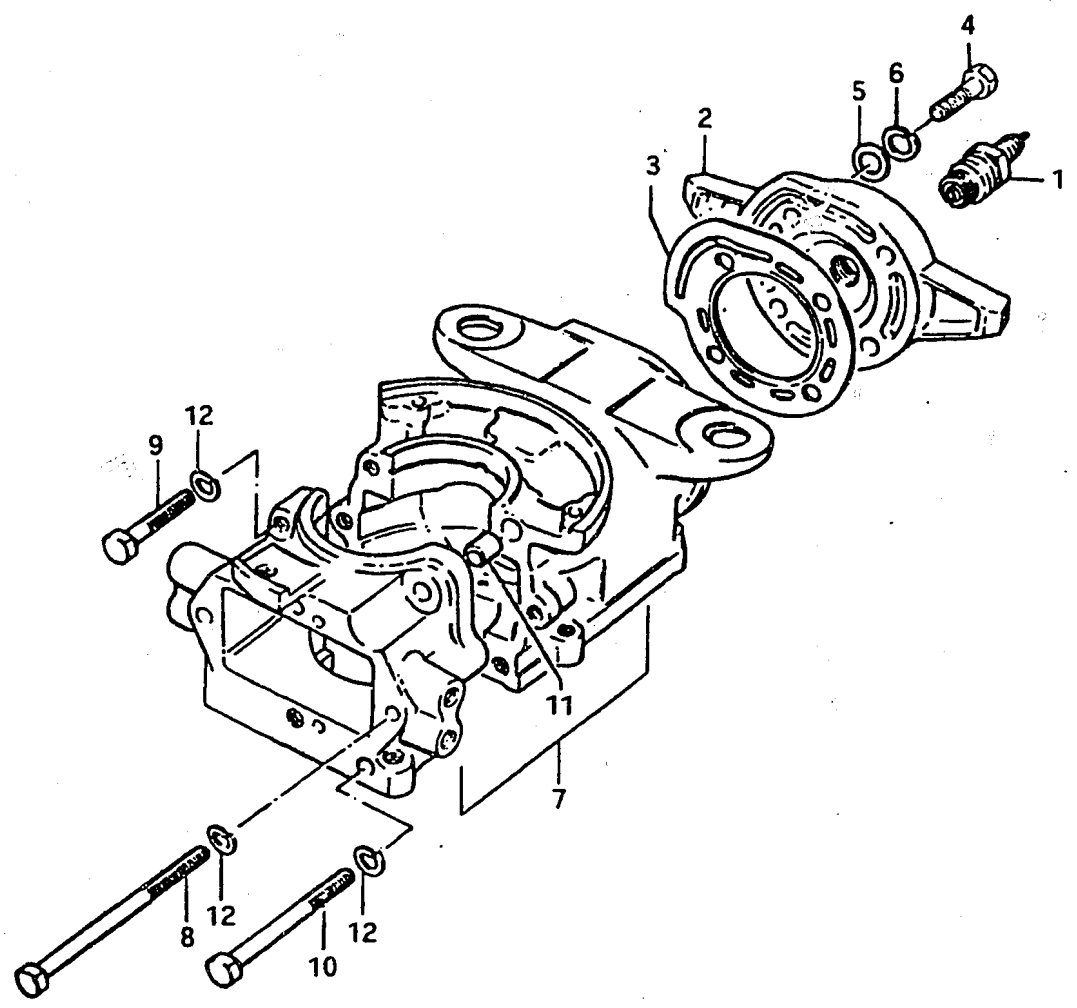

FIG.31 CYLINDER

Ref. No.	Part No.	Description	Q'ty		Remarks
			C	D	
1-1	09482-00095	SPARK PLUG ASSY	1	-	B-6HS, NGK from 09482-00048
1-2	09482-00088	SPARK PLUG ASSY	1	-	BR-6HS, E28
1-3	09482-00088	SPARK PLUG ASSY	-	1	BR-6HS
2	11111-98003	CYLINDER HEAD	1	1	
3	11141-98005	GASKET, cylinder head	1	1	
4	01107-08358	BOLT	4	4	
5	08322-11088	WASHER	4	4	
6	08321-21088	LOCK WASHER	4	4	
7-1	11300-98831	CYLINDER/CRANKCASE ASSY	1	-	to (11300-98832) + (12110-98006)
7-2	11300-98832	CYLINDER/CRANKCASE ASSY	-	1	
8	09100-06032	·BOLT, cylinder 1	2	2	6x80
9	09100-06033	·BOLT, cylinder 2	2	2	6x35
10	09100-06038	·BOLT, cylinder 3	2	2	6x65
11	04211-09109	·DOWEL PIN	2	2	
12	08321-21068	·LOCK WASHER	6	6	

FIG. 32

E - 4

FIG. 32 REED VALVE

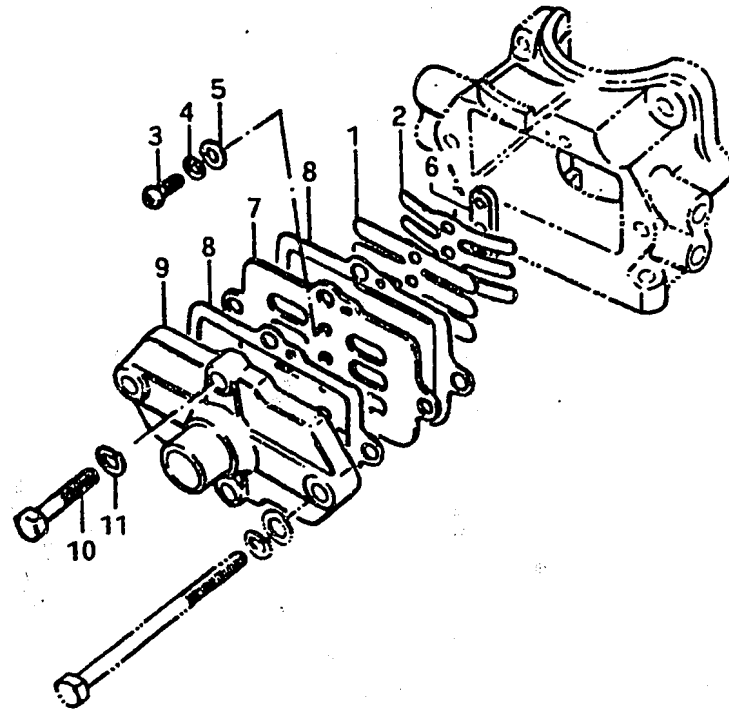

Ref. No.	Part No.	Description	Q'ty		Remarks
			C	D	
1	12411-98001	VALVE, reed	1	1	from 12411-98000
2	12421-98002	STOPPER, reed valve	1	1	
3	02112-04128	SCREW	3	3	
4	08321-21048	LOCK WASHER	3	3	
5	08322-21048	WASHER	3	3	
6	12431-98001	PLATE, reed valve	1	1	
7	12441-98030	SEAT, reed valve	1	1	
8	12451-98000	GASKET, valve seat	2	2	
9	12481-98002	CASE, inlet	1	1	
10	01107-06308	BOLT	2	2	
11	08321-21068	LOCK WASHER	2	2	

FIG. 33

E - 5

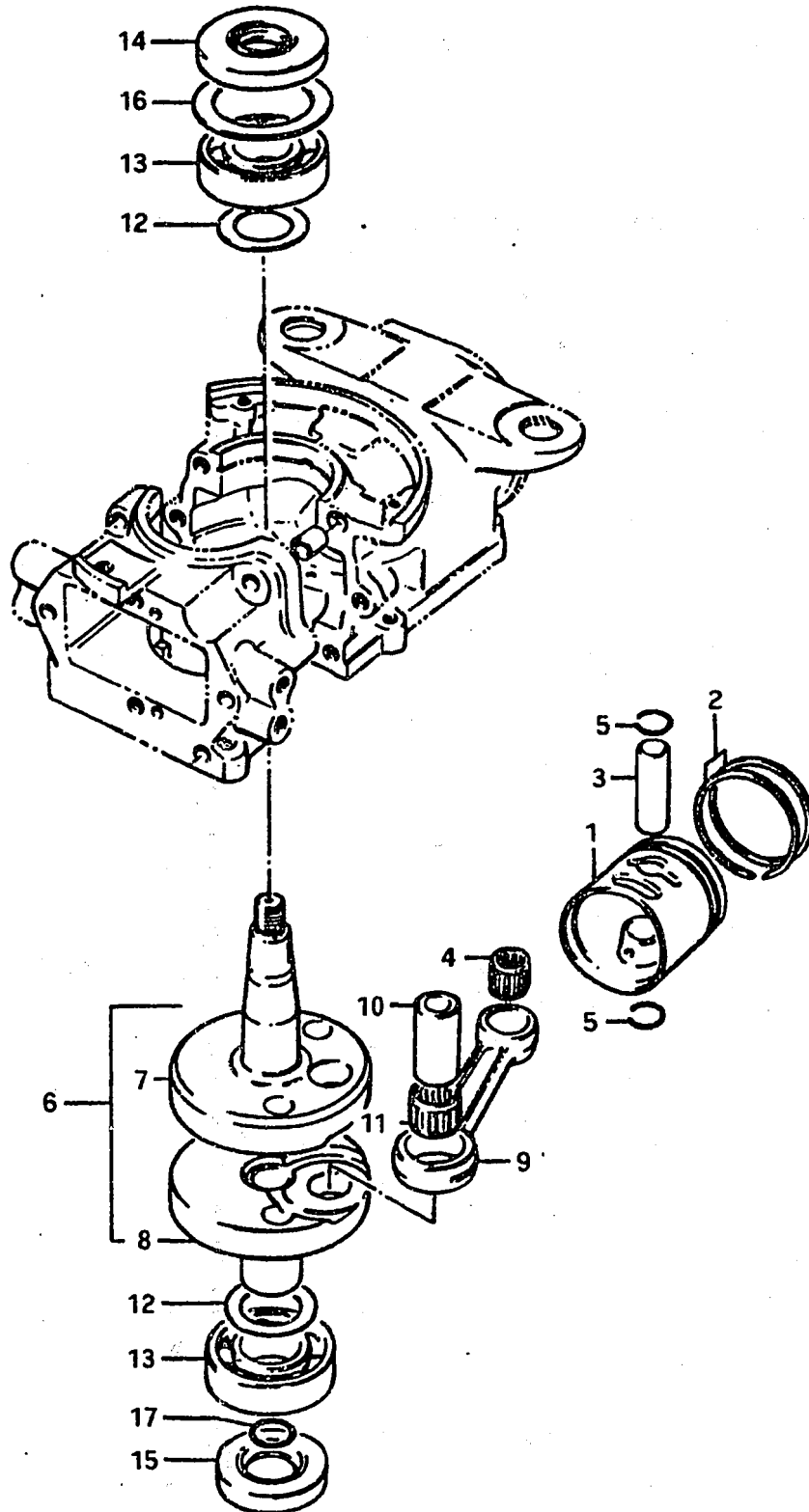

FIG. 33 CRANKSHAFT

Ref. No.	Part No.	Description	Q'ty		Remarks
			C	D	
1-1	12110-98005	PISTON	1	-	to 12110-9800E
1-2	12110-98006	PISTON	-	1	
1-3	12110-98006-025	PISTON	-	1	OS:0.25,OPT from 12110-98720
1-4	12110-98006-050	PISTON	-	1	OS:0.50,OPT from 12110-98730
2-1	12140-98013	RING SET, piston	1	1	T:1.5
2-2	12140-98013-025	RING SET, piston	-	1	OS:0.25,OPT from 12140-98720
2-3	12140-19610-050	RING SET, piston	-	1	OS:0.50,OPT from 12140-19760
3	12151-98000	PIN, piston	1	1	
4	09263-12003	BEARING, piston pin	1	1	12x15.7x15.8
5	09381-12001	CIRCLIP, piston pin	2	2	
6-1	12200-98820	CRANKSHAFT SET	1	-	
6-2	12200-98821	CRANKSHAFT SET	-	1	from 12200-98820 to 12200-98822
6-3	12200-98822	CRANKSHAFT SET	-	1	to 12200-98823
6-4	12200-98823	CRANKSHAFT SET	-	1	DT4D-10767~
7	12221-98003	•CRANKSHAFT, upper	1	1	
8-1	12230-98000	•CRANKSHAFT, lower	1	-	to 12230-98001
8-2	12230-98001	•CRANKSHAFT, lower	-	1	to 12230-98002
8-3	12230-98002	•CRANKSHAFT, lower	-	1	DT4D-10767~
9	12161-35000	•ROD, connecting	1	1	
10	12211-98000	•PIN, crank	1	1	
11	09263-16014	•BEARING, crank pin	1	1	from 09263-16002
12	08221-20285	•SHIM	1	-	for 12230-98000
13	08113-62040	•BEARING	2	2	
14	09283-20016	OIL SEAL, crankshaft upper	1	1	20x47x8
15	09283-20018	OIL SEAL, crankshaft lower	1	1	20x37x9
16	09160-38001	THRUST WASHER	1	1	38x51x1.0
17	09280-15002	O RING, lower crankshaft	1	1	ID:15,d:1.9

FIG. 34

E - 6

FIG. 34 CARBURETOR

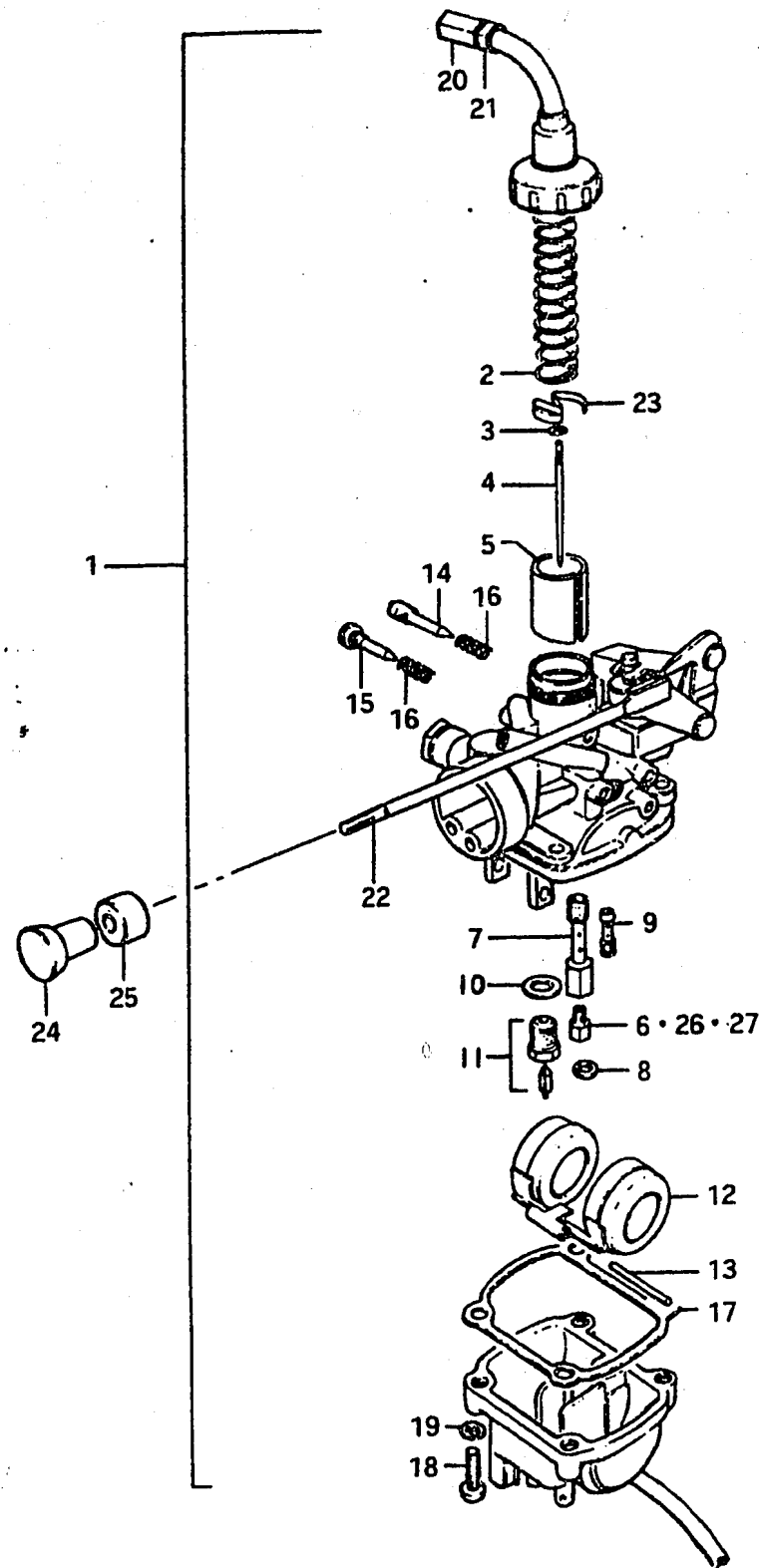

Ref. No.	Part No.	Description	Q'ty		Remarks
			C	D	
1-1	13200-98018	CARBURETOR ASSY	1	-	to 13200-98019
1-2	13200-98019	CARBURETOR ASSY	-	1	to 13200-98020
1-3	13200-98020	CARBURETOR ASSY	-	1	DT4D-11732~
2	13573-01010	•SPRING, throttle valve	1	1	
3	13394-12110	•CLIP, needle	1	1	
4	13383-19600	•NEEDLE, jet	1	1	3J2
5	13551-98012	•VALVE, throttle	1	1	CA:2.0
6	09491-95001	•JET, main	1	1	95
7	09494-00071	•NOZZLE, needle	1	1	
8	13691-98010	•O RING, float chamber	1	1	
9	09492-25002	•JET, pilot	1	1	25
10	13392-01010	•GASKET, valve seat	1	1	
11-1	13370-23010	•VALVE ASSY, needle	1	1	
11-2	13370-98010	•VALVE ASSY, needle	-	1	DT4D-11732~
12	13252-02010	•FLOAT	1	1	
13	13254-01010	•PIN, float	1	1	
14	13269-01010	•SCREW, pilot air	1	1	
15	13267-98010	•SCREW, throttle stop	1	1	
16	13268-95110	•SPRING, stop screw	2	2	
17	13251-98011	•GASKET, float chamber	1	1	
18	02112-04168	•SCREW	4	4	
19	08321-21048	•LOCK WASHER	4	4	
20	13577-98011	•ADJUSTER, throttle cable	1	1	
21	13661-03010	•NUT, adjusting	1	1	
22-1	13413-98010	•LEVER, starter	1	-	to 13413-98011
22-2	13413-98011	•LEVER, starter	-	1	
23	13581-01010	•SEAT, throttle valve spring	1	1	
24	13631-99002	KNOB, starter	1	1	to 13631-93500
25	09305-04001	BUSHING, starter guide	1	1	
26	09491-90001	JET, main	1	1	OPT,90
27	09491-20001	JET, main	1	1	OPT,100

FIG. 35

E - 7

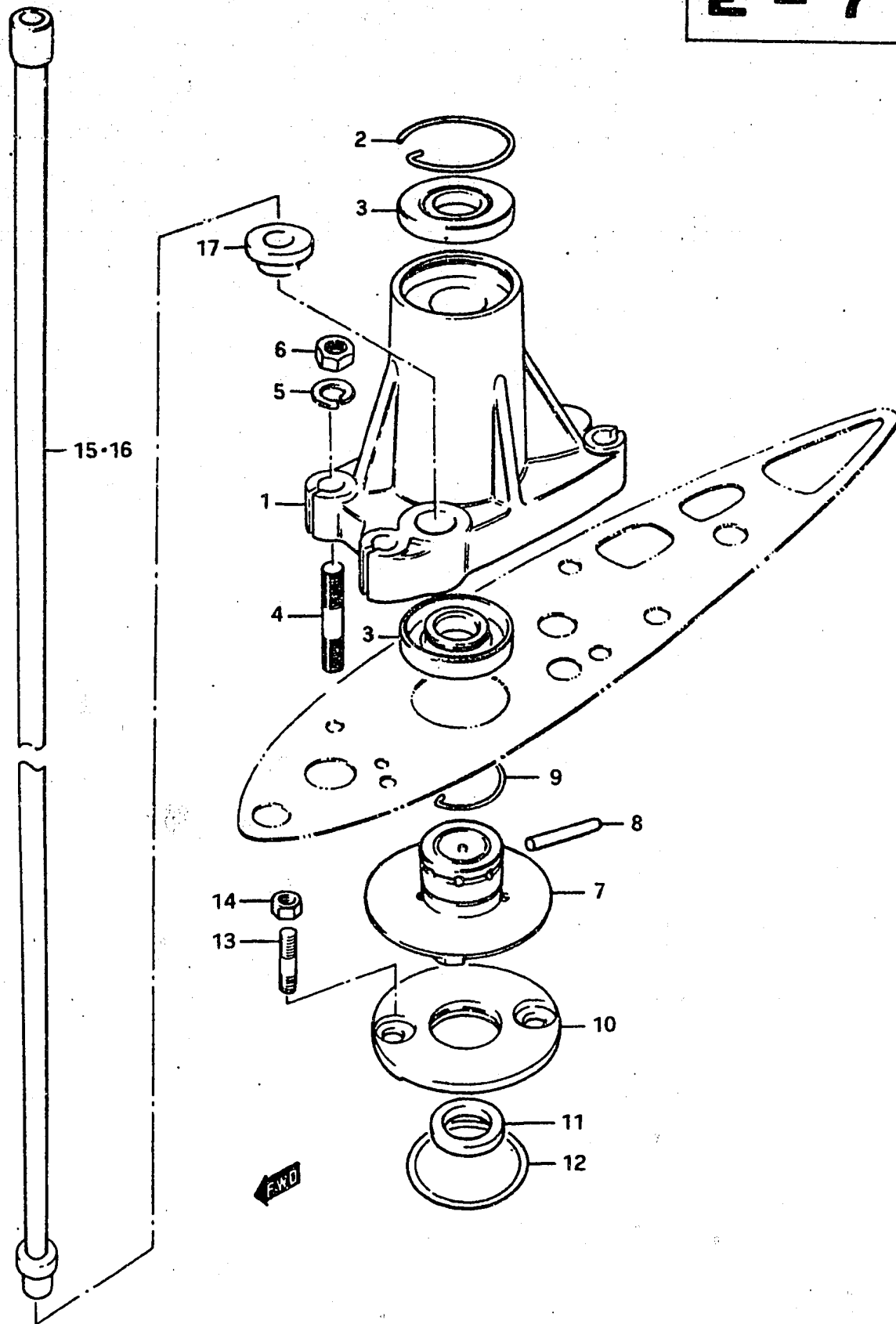

FIG. 35 WATER PUMP

Ref. No.	Part No.	Description	Q'ty		Remarks
			C	D	
1	17420-99002	HOUSING, pinion shaft	1	1	
2	09387-32001	CIRCLIP, oil seal	1	1	
3	09283-15001	OIL SEAL, pinion shaft	2	2	15x30x7.5
4	09108-06025	STUD BOLT, housing	4	4	6x30
5	09162-06001	LOCK WASHER, housing	4	4	
6	09140-06004	NUT, housing	4	4	
7	17460-99002	IMPELLER, water pump	1	1	
8	09202-04002	PIN, impeller	1	1	4x24
9	09387-28001	CIRCLIP, impeller	1	1	
10	17491-99000	PLATE, water pump lower	1	1	
11	09289-15001	OIL SEAL, lower plate	1	1	15x30x7.5
12	09280-33002	O.RING, lower plate	1	1	ID:33,d:2.2
13	09108-05002	STUD BOLT, lower plate	2	2	5x4
14	09140-05001	NUT, lower plate	2	2	
15	17561-99102	TUBE, water	1	1	S type,L:484
16	17561-99202	TUBE, water	1	1	L type,L:637
17	09305-08007	BUSHING, water tube	1	1	from 09305-08005

S type.....Transom 16"
 L type.....Transom 22"

FIG. 36

E - 8

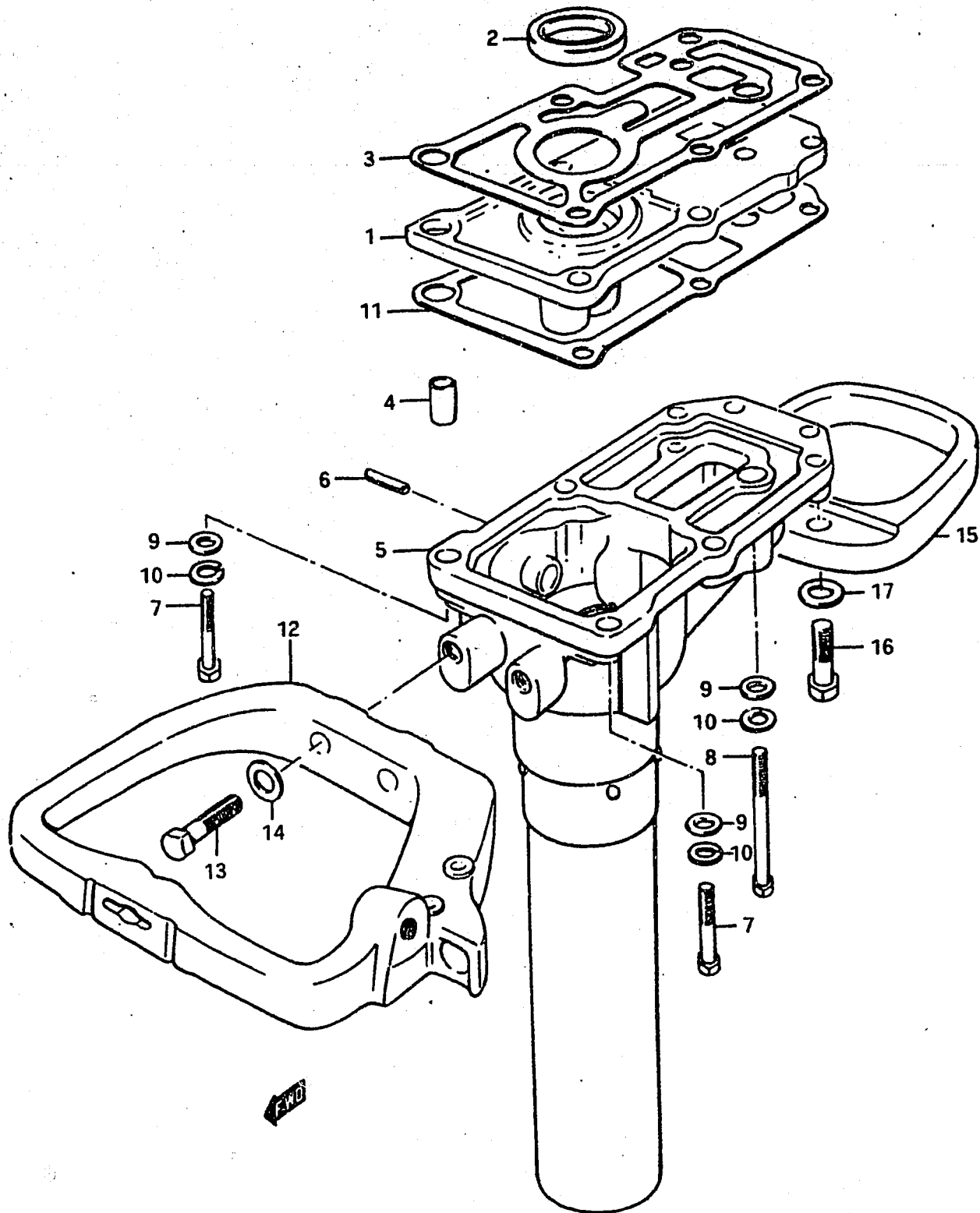

FIG.36 ENGINE HOLDER

Ref. No.	Part No.	Description	Q'ty		Remarks
			C	D	
1	17530-98002	HOLDER, water tube	1	1	
2	09283-20022	OIL SEAL, water tube holder	1	1	20x35x9 to 09283-20035
3	17591-98004	GASKET, water tube holder	1	1	
4	09206-09003	DOWEL PIN, water tube holder	2	2	OD:9,L:20
5	51100-98200-01J	HOLDER, engine	1	1	
6	09205-05001	DOWEL PIN	1	1	
7	09100-06035	BOLT, engine holder 2	6	6	6x40
8	09100-06044	BOLT, engine holder 3	2	2	6x65
9	09160-06015	WASHER, engine holder	8	8	6.5x11.5x0.8
10	09162-06001	LOCK WASHER, engine holder	8	-	
11	51211-98003	GASKET, engine holder	1	1	
12	62111-98001-01J	GUARD, front	1	1	
13	01107-08308	BOLT	2	2	
14	09160-08015	WASHER	2	2	8.5x16x1.2
15	62411-98701-01J	BRACE, rear	1	1	
16	01107-08308	BOLT	2	2	
17	09160-08015	WASHER	2	2	8.5x16x1.2

FIG. 37

E - 9

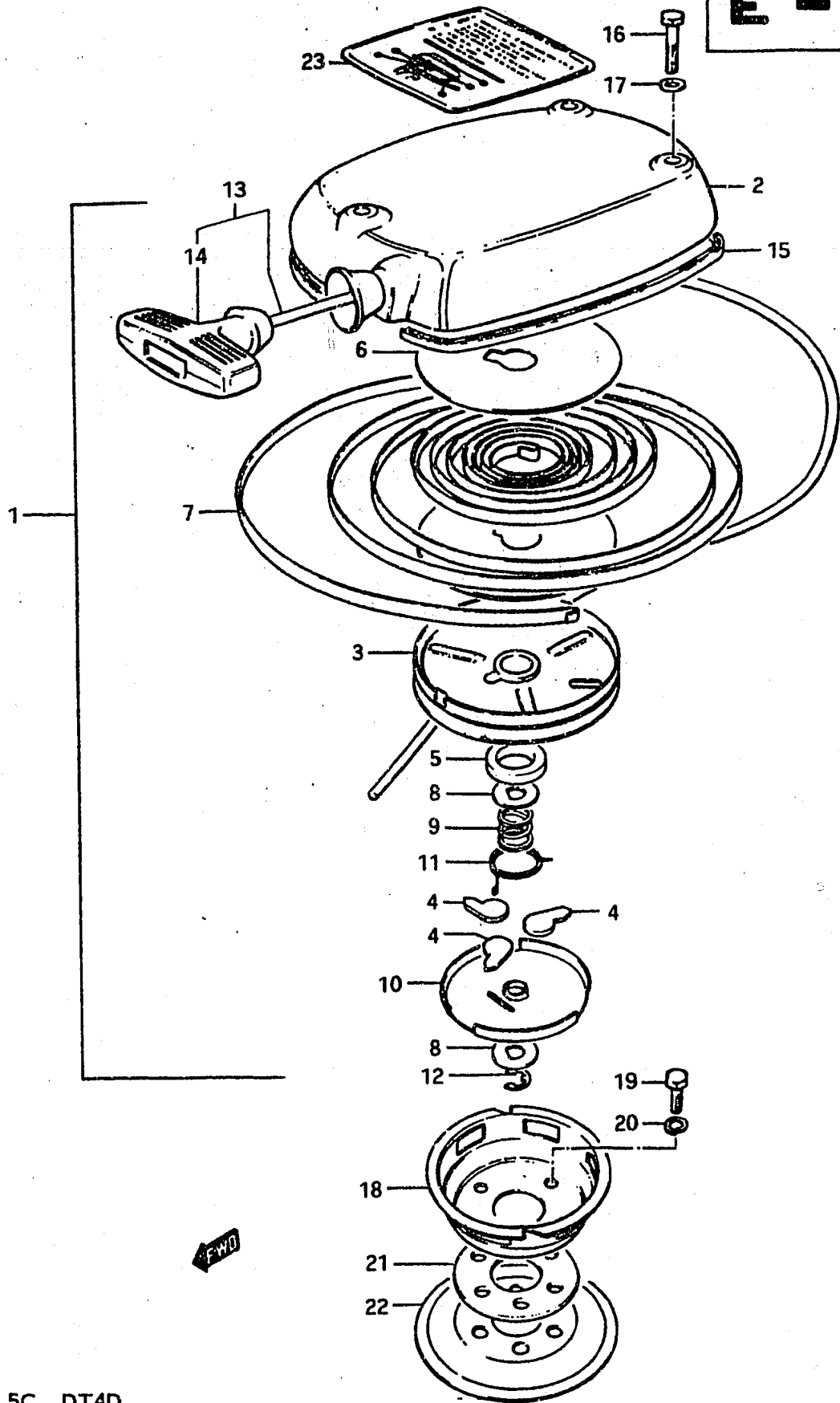

FIG. 37 STARTER

Ref. No.	Part No.	Description	Q'ty		Remarks
			C	D	
1-1	18100-98004-01T	STARTER ASSY, recoil	1	-	to 18100-98005-01T
1-2	18100-98005-01T	STARTER ASSY, recoil	-	1	
2	18111-98001-01T	•CASE, starter	1	1	
3	18121-98001	•DRUM, sheave	1	1	
4	18131-98001	•PAWL, drive	3	3	
5	18125-98000	•FELT, oil	1	1	
6	18138-98000	•SPACER, spring	2	2	to 18138-98001
7	18142-98001	•SPRING, recoiling	1	1	
8	18143-98001	•WASHER, sheave drum	2	2	
9	18145-98001	•SPRING, pivot shaft	1	1	
10	18151-98002	•PLATE, drive	1	1	
11	18155-98000	•SPRING, return	1	1	
12	18163-98001	•CIRCLIP, drive plate	1	1	
13-1	18200-93810	•GRIP ASSY, starter	1	-	to 18200-93811
13-2	18200-93811	•GRIP ASSY, starter	-	1	to 18200-93100
14-1	18210-93000	•GRIP, starter	1	-	from 18211-98000 to 18210-93001
14-2	18210-93001	•GRIP, starter	-	1	
15	18251-98000	•RUBBER, starter seal	1	1	
16	09100-06022	BOLT, starter case	3	3	6x35
17	09160-06015	WASHER, starter case	3	3	6.5x11.5x0.8
18	18411-98002	CUP, starter	1	1	
19	01107-06168	BOLT	3	3	
20	08321-21068	LOCK WASHER	3	3	
21	18511-98000	SPACER, starter cup	1	1	
22-1	32725-98000	INSULATOR, magneto	1	-	
22-2	32725-98400	INSULATOR, magneto	-	1	from 32725-98000
23-1	61511-99611	MARK, start indicate	1	-	to 61511-93602
23-2	61511-93602	MARK, start indicate	-	1	

FIG. 38

E - 10

FIG. 38 MAGNETO

Ref. No.	Part No.	Description	Q'ty		Remarks
			C	D	
1	32100-98035	MAGNETO ASSY	1	1	
2	32101-98036	•STATOR ASSY	1	1	to 32101-98038
3	32140-98035	••COIL, primary	1	1	
4	02112-05208	••SCREW	2	2	
5	08321-21058	••LOCK WASHER	2	2	
6	32240-98034	••POINT, contact	1	1	from 32240-98033
7	32341-98030	••CONDENSER	1	1	
8	02112-03088	••SCREW	1	1	
9	02111-03108	••SCREW	1	1	
10	08321-21038	••LOCK WASHER	2	2	
11	08322-21038	••WASHER	1	1	
12	02112-05128	SCREW	2	2	
13	08322-11058	WASHER	2	2	
14	08341-31039	KEY	1	1	
15	08321-21108	LOCK WASHER	1	1	
16	08310-12108	NUT	1	1	

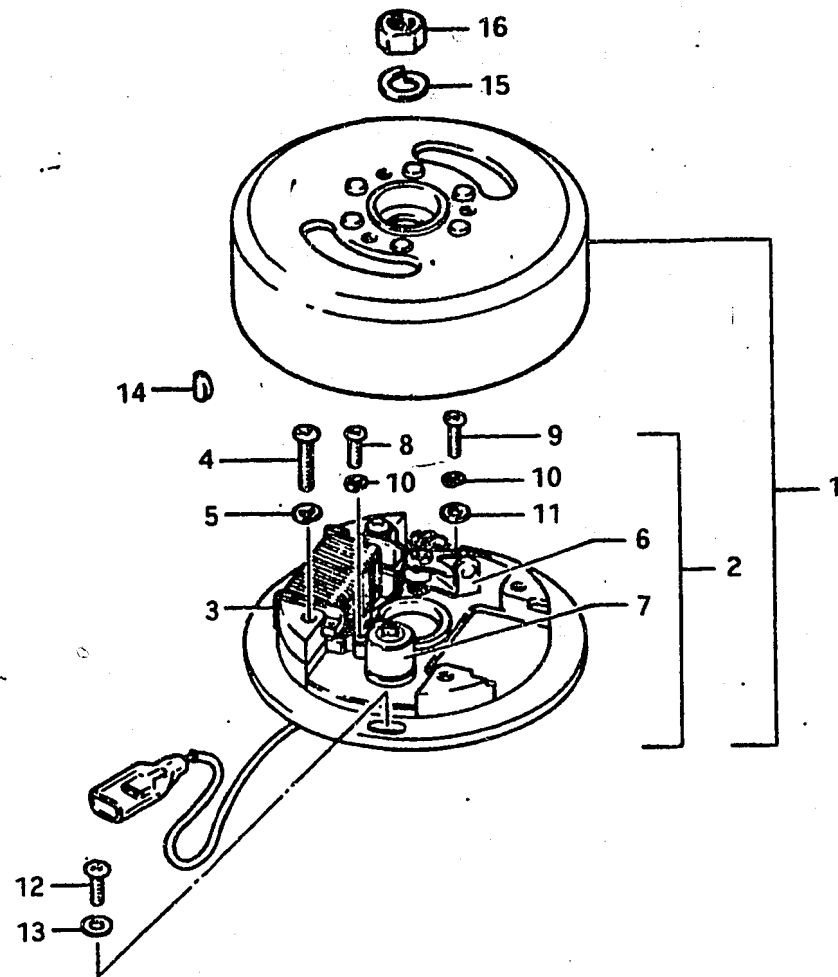
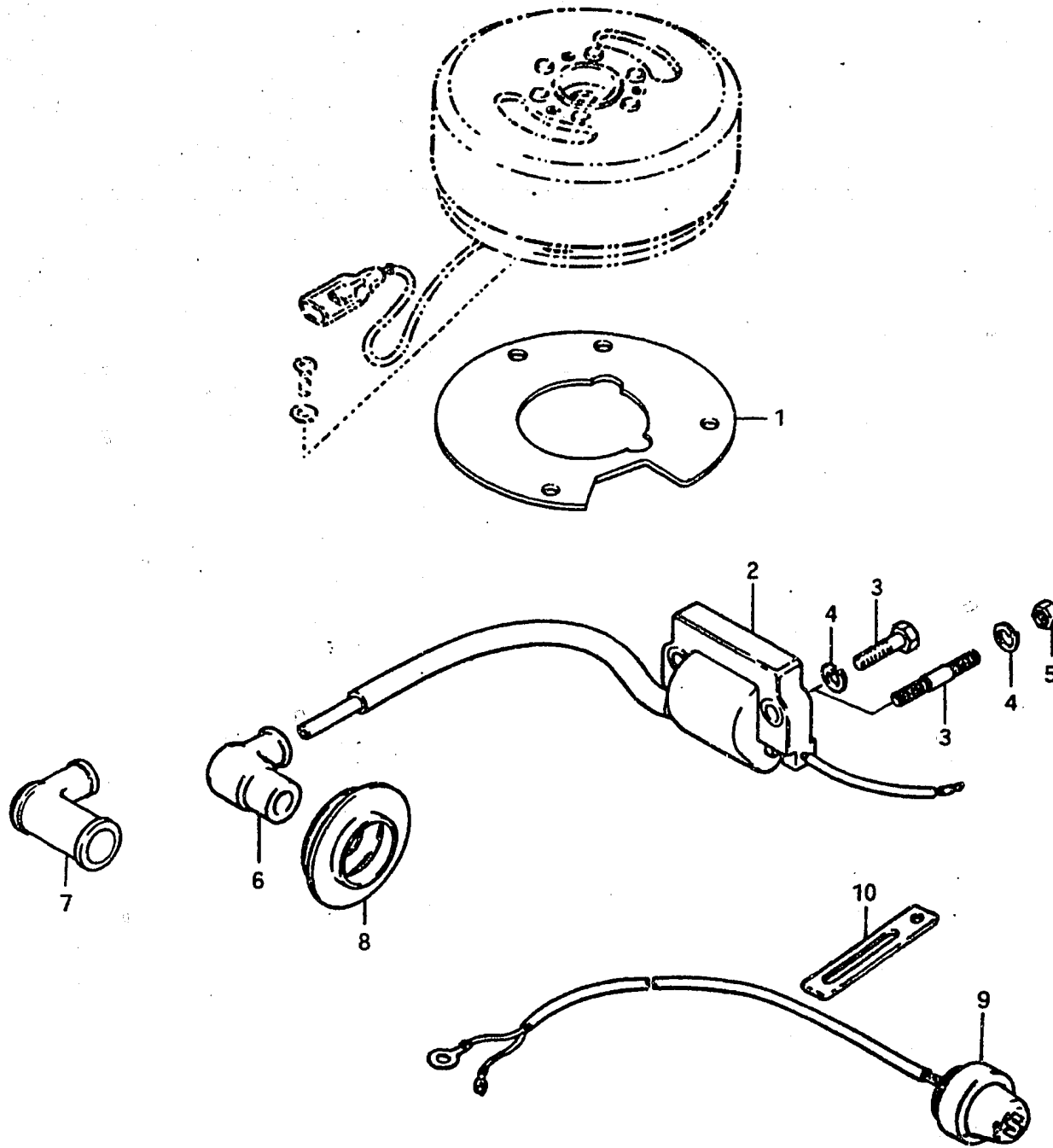

FIG. 39

E - 11

FIG. 39 ELECTRICAL



Ref. No.	Part No.	Description	Qty		Remarks
			C	D	
1	32731-98002	PLATE, magneto seal	1	1	
2	33410-98030	COIL ASSY, ignition	1	1	
3	08321-21068	LOCK WASHER	2	2	
4	01421-06258	STUD BOLT	2	2	
5	08310-11068	NUT	2	2	
6	33510-41111	CAP, spark plug	1	-	to 33510-95510
7	33510-28300	CAP, spark plug	-	1	
8	33543-98000	BOOT, spark plug	1	1	
9-1	37800-99014	SWITCH ASSY, engine stop	1	-	to 37800-99015
9-2	37800-99015	SWITCH ASSY, engine stop	-	1	to 37800-99016
10	09404-08413	CLAMP, stop switch read cord	1	1	T:1.0

FIG. 40

E - 12

FIG. 40 CLUTCH

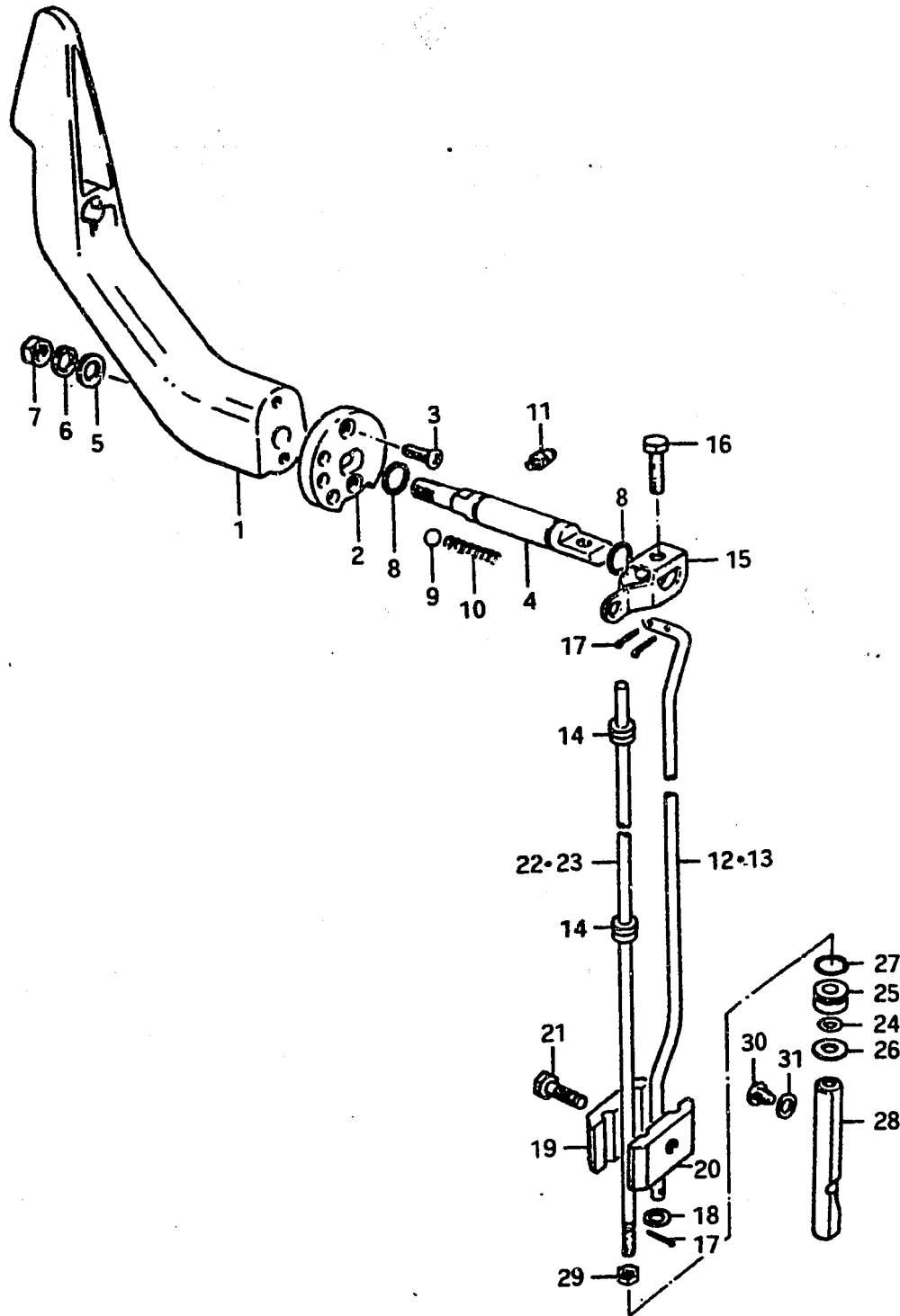

Ref. No.	Part No.	Description	Q'ty		Remarks
			C	D	
1-1	21111-93100-01J	LEVER, clutch	1	-	to 21111-93101-01J
1-2	21111-93101-01J	LEVER, clutch	1	-	to 21111-93102-01J
1-3	21111-93103-01J	LEVER, clutch	-	1	from 21111-93102-01J
2	21112-93100	PLATE, clutch lever	1	1	
3	02122-04128	SCREW	2	2	
4	21211-93100	SHAFT, clutch lever	1	1	L:72, to 21211-93101
5-1	08322-11088	WASHER	1	-	
5-2	09160-08015	WASHER	-	1	
6	09162-08003	LOCK WASHER	1	1	
7	09140-08003	NUT, clutch lever	1	1	
8	09280-09003	O RING, clutch lever shaft	2	2	ID:8.8,d:1.9
9	09260-10003	BALL, clutch notch	1	1	
10	09440-07021	SPRING, clutch notch	1	1	
11	22511-99000	GREASE NIPPLE, clutch lever	1	1	
12	23111-99102	ROD, clutch	1	1	S type,L:407
13	23111-99202	ROD, clutch	1	1	L type,L:560
14	09305-06006	BUSHING, push rod 2	2	2	
15	23211-99002	ARM, clutch	1	1	from 23211-99001
16	09100-06019	BOLT, clutch arm	1	1	6x16
17	09204-01001	COTTER PIN, clutch rod	3	3	OD:1.8,L:10
18	09160-06015	WASHER, clutch rod	1	1	6.5x11.5x0.8
19	23311-99001	CONNECTOR, clutch rod (1)	1	1	
20	23321-99001	CONNECTOR, clutch rod (2)	1	1	
21	09100-06020	BOLT, clutch rod	1	1	6x20
22	25111-99700	ROD, shifting	1	1	S type,L:345
23	25111-99005	ROD, shifting	1	1	L type,L:498
24	09280-06004	O RING, shifting rod	1	1	ID:5.8,d:3.5
25	25211-99004	GUIDE, shifting rod	1	1	
26	08212-06151	WASHER	1	1	
27	09280-11001	O RING, shifting rod guide	1	1	ID:11,d:2.4
28	25311-99004	CAM, shifting	1	1	
29	08310-11068	NUT	1	1	
30	09139-06003	SCREW, shifting cam stop	1	1	
31	09168-06002	GASKET, cam stop screw	1	1	6.2x12x1.5

FIG.41

E - 13

FIG.41 HANDLE - GRIP

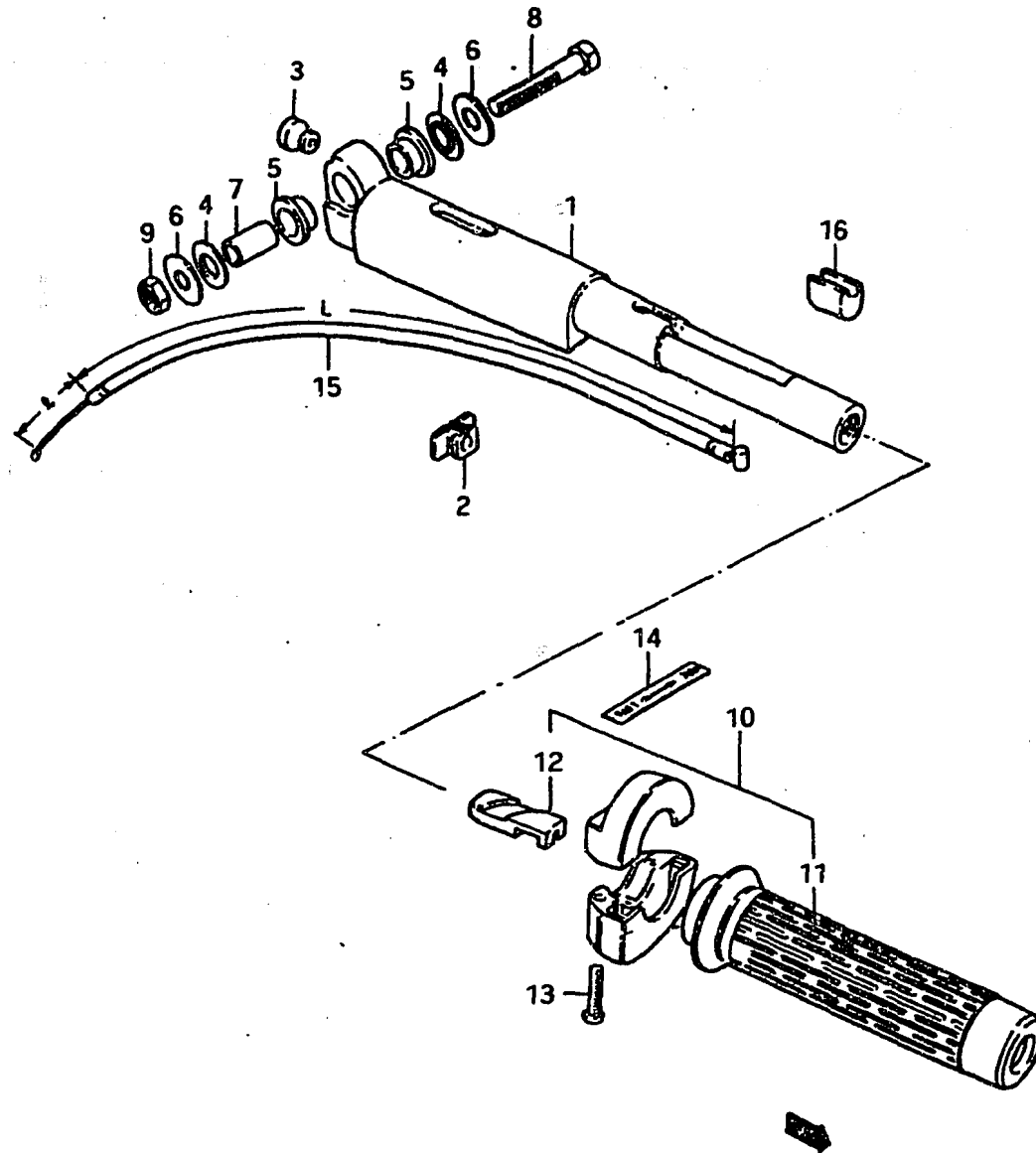

Ref. No.	Part No.	Description	Q'ty		Remarks
			C	D	
1	63111-93102-01J	HANDLE, tiller	1	1	
2	63112-93103	GROMMET, stop switch wire	1	1	
3	09321-07001	CUSHION, handle	1	1	
4	63321-99000	SEAT, handle rubber	2	2	
5	09305-12007	BUSHING, handle cushion	2	2	
6	09160-10041	WASHER, handle pivot	2	2	10.3x25x1.6
7	09303-10001	SPACER, handle pivot	1	1	10.5x12.5x24
8	09100-10091	BOLT, handle pivot	1	1	10x55
9	09140-10017	NUT, handle	1	1	
10	63200-93101	GRIP ASSY, throttle	1	1	to 63200-93102
11	63210-93101	GRIP, throttle	1	1	to 63210-93102
12	63214-93100	PIECE, sliding	1	1	
13	63218-93100	SCREW, cover	2	2	
14-1	63215-93100	MARK, handle grip	1	-	to 63215-93101
14-2	63215-93101	MARK, handle grip	-	1	
15	63610-98002	CABLE ASSY, throttle	1	1	L:470, L:98
16	63331-93100	CUSHION, handle	1	1	to 63331-93101

FIG.42

E - 14

FIG.42 CLAMP BRACKET

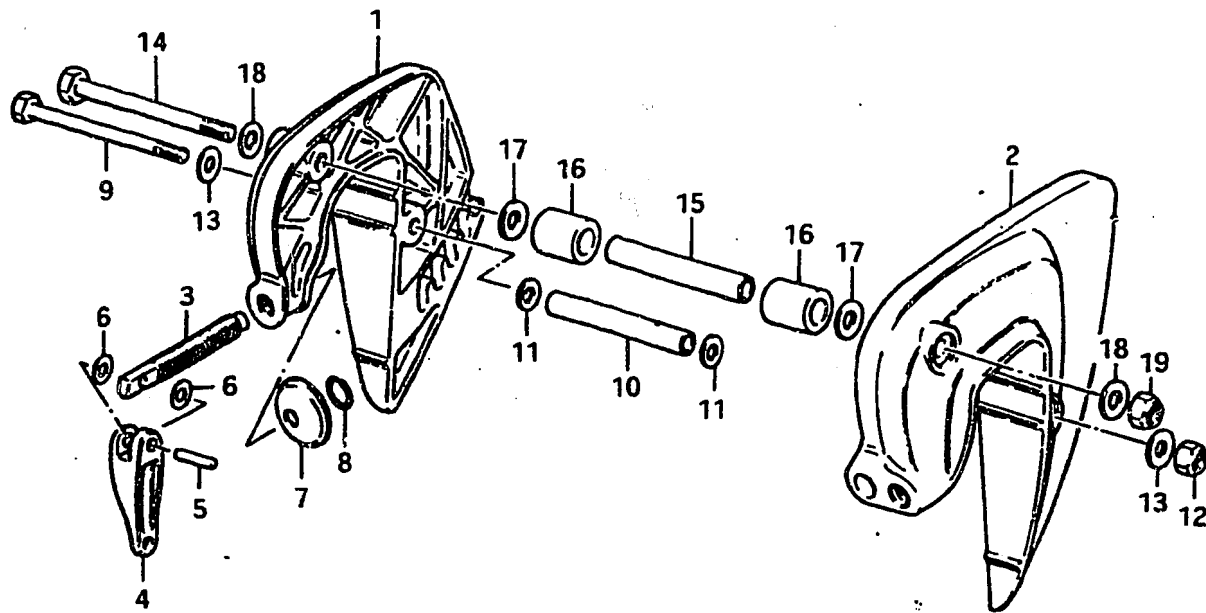

Ref. No.	Part No.	Description	Q'ty		Remarks
			C	D	
1	41111-99003-01J	BRACKET, clamp RH	1	1	
2	41121-99004-01J	BRACKET, clamp LH	1	1	
3-1	41211-99001	SCREW, clamp	2	2	
3-2	41211-99700	SCREW, clamp	2	2	OPT
4	41212-99000-01J	HANDLE, clamp	2	2	
5	09205-05001	PIN, clamp handle	2	2	5.2x18 from 09209-05005
6	09181-05001	SHIM	AR(0~4)		5.2x13x0.1
7	41213-99001	PLATE, clamp	2	2	
8	09380-07001	RING, clamp plate	2	2	
9	09100-06068	BOLT, clamp shaft	1	1	6x150 from 41311-99000
10	09180-06007	SPACER, clamp shaft	1	1	6.5x10.5x85
11	08322-21068	WASHER	2	2	
12	09159-06015	NUT, clamp shaft	1	1	from 09159-06010
13	09160-06013	WASHER, clamp shaft	2	2	6.5x18x2
14	09100-08080	BOLT, swivel shaft	1	1	
15	09180-08069	SPACER, swivel shaft	1	1	8.1x12x85
16	09300-11003	BUSHING, swivel support	2	2	11.8x22x23
17	09160-08007	SPACER, swivel bracket	2	2	8.5x18x2
18	08322-11088	WASHER	2	2	
19	09159-08018	NUT, swivel bracket	1	1	

FIG.43

E - 15

FIG.43 SWIVEL BRACKET

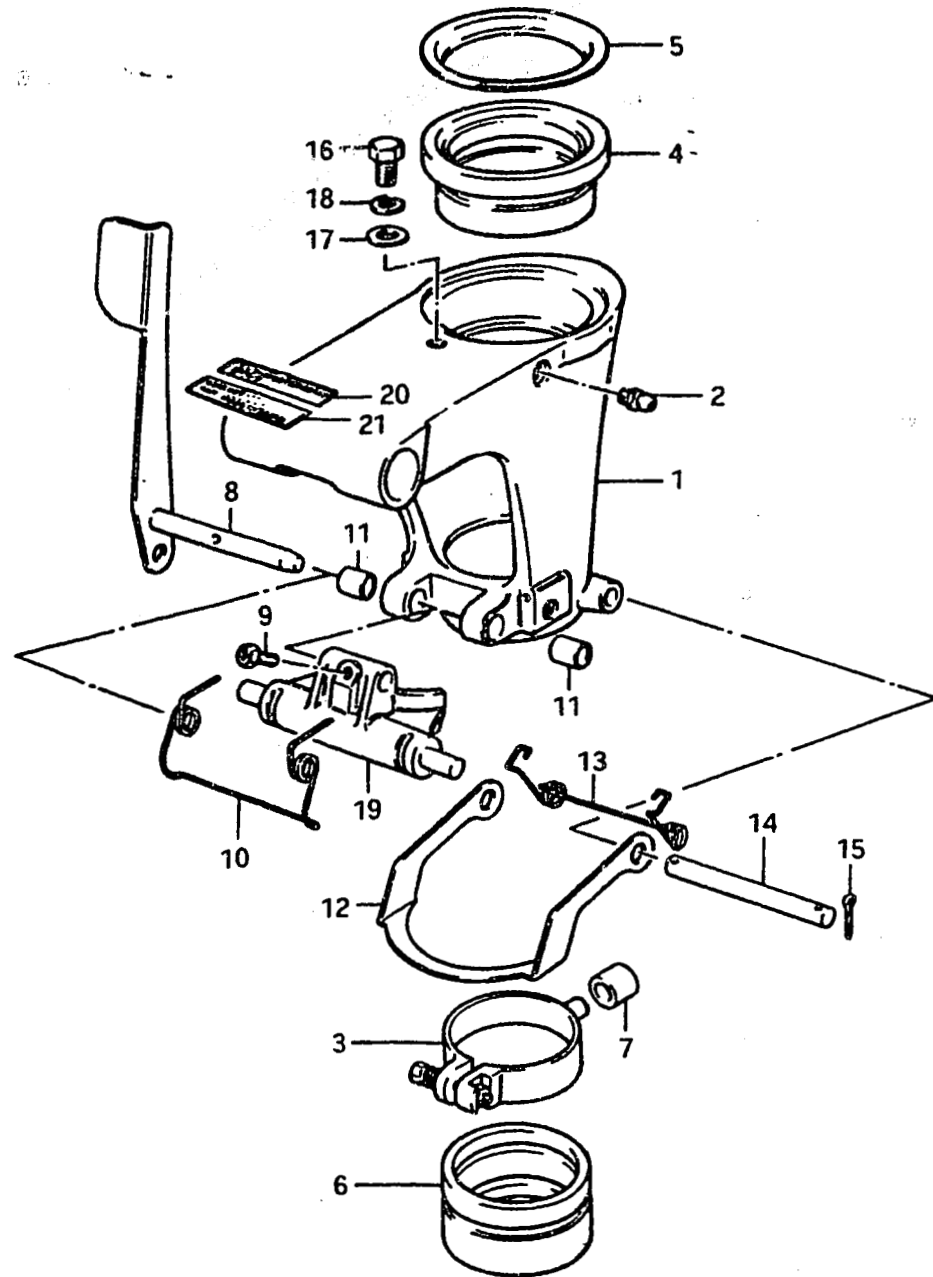

Ref. No.	Part No.	Description	Q'ty		Remarks
			C	D	
1	43111-99402-01J	BRACKET, swivel	1	1	
2	22511-99000	GREASE NIPPLE	2	2	
3	43410-99001	ADJUSTER, steering	1	1	
4	43711-98000	BUSHING, steering upper	1	1	
5	43712-99001	PLATE, steering upper	1	1	
6	43721-98000	BUSHING, steering lower	1	1	
7	09300-11004	BUSHING, steering adjuster	1	1	11.8x22x11.8
8	45110-99000	LEVER, rack	1	1	
9	09139-05003	SCREW, rack lever	1	1	5x8
10	45211-96000	SPRING, rack lever	1	1	
11	09300-08005	BUSHING, rack lever	2	2	28x10x14
12	45231-99401	ARM, reverse lock	1	1	
13	45212-99401	SPRING, reverse lock arm	1	1	
14	09200-08018	PIN, reverse lock arm	1	1	OD:8,L:89
15	09204-01001	COTTER PIN	2	2	OD:1.8,L:10
16	01107-08128	BOLT	1	1	
17	08322-11088	WASHER	1	1	
18	08321-31088	LOCK WASHER	1	1	
19	45411-99003	BLOCK, thrust	1	1	
20	43221-98615	PLATE, name	1	-	
21-1	43222-98000	PLATE, name	1	-	
21-2	43224-98002	PLATE, name	-	1	

FIG.44

F - 2

FIG.44 DRIVE SHAFT HOUSING

Ref. No.	Part No.	Description	Q'ty		Remarks
			C	D	
1	52101-99816-01J	HOUSING ASSY, driveshaft	1	1	
2	52101-99817-01J	HOUSING ASSY, driveshaft	1	1	
3	09108-06007	•STUD BOLT, housing	4	4	6x25
4	09160-06015	•WASHER, housing	4	4	6.5x11.5x0.5
5	09140-06004	•NUT, housing	4	4	
6	09280-50002	O RING, drive shaft housing	1	1	ID:50,d:3.1
7	52112-99000	GROMMET, drive shaft housing	1	1	
8	09250-36001	CAP, clutch adjusting hole	1	1	
9	53131-99000	COVER, stud bolt	1	1	

S type.....Transom 16"
 L type.....Transom 22"

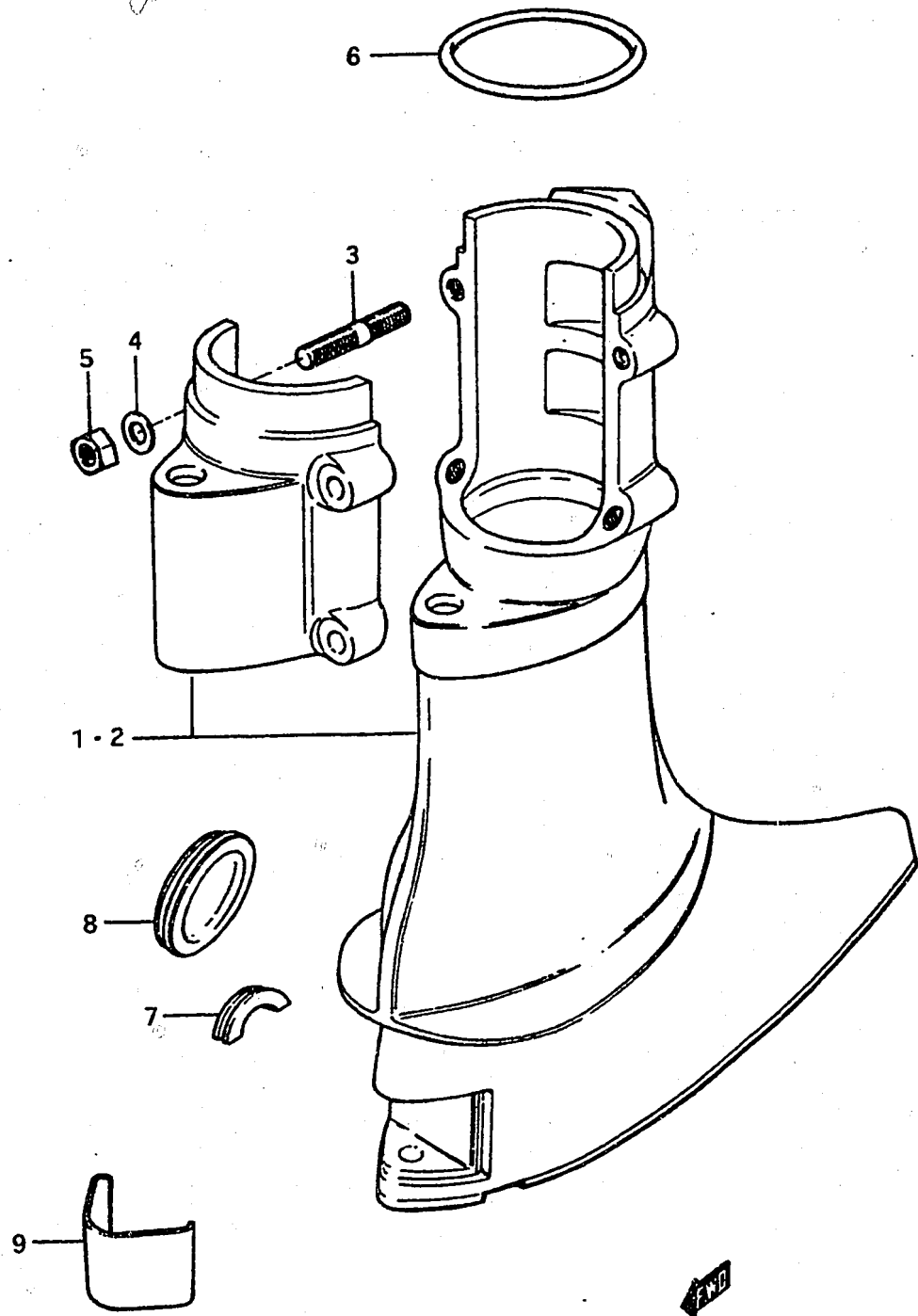

FIG.45

F - 3

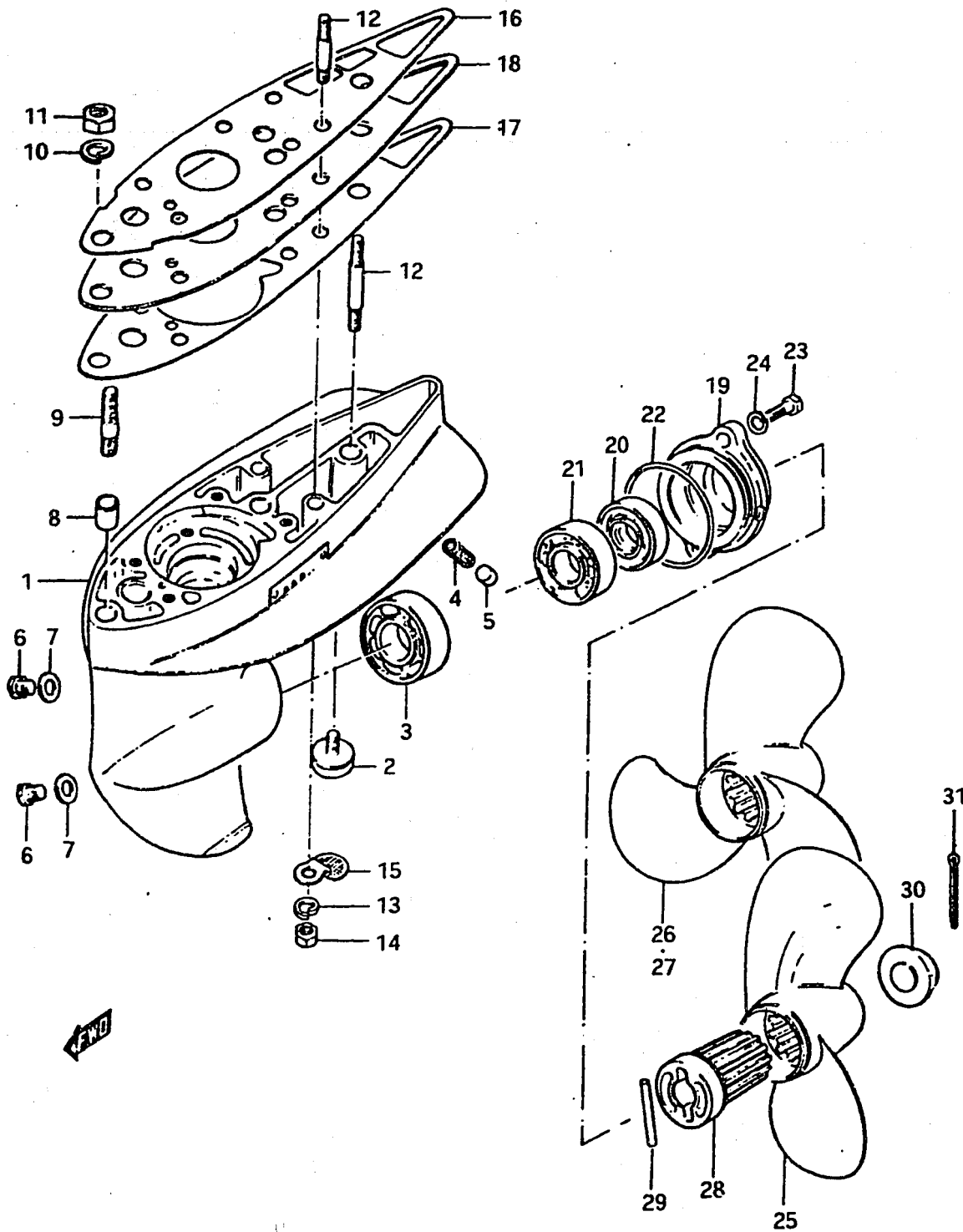

FIG.45 GEAR CASE - PROPELLER

Ref. No.	Part No.	Description	Q'ty		Remarks
			C	D	
1	55100-99830-01J	CASE ASSY, gear	1	1	
2	55321-93141	·ZINC, protection	1	1	from 55321-93140
3	08113-62040	·BEARING	1	1	20x47x14
4	17631-99000	FILTER, water	1	1	
5	09243-12001	PLUG, water	1	1	
6	09248-10003	PLUG, drain	2	2	
7	09168-10004	GASKET, drain plug	2	2	10x17x1.5 to 09168-10022
8	09205-11001	DOWEL PIN, gear case	1	1	11x14
9	09108-08029	STUD BOLT, gear case 1	1	1	8x40
10	09162-08003	LOCK WASHER, gear case 1	1	1	
11	09140-08003	NUT, gear case	1	1	
12	09108-06014	STUD BOLT, gear case 2	3	3	6x40
13	09162-06001	LOCK WASHER, gear case	3	3	
14	09140-06004	NUT, gear case	3	3	
15	17641-99000	COVER, water inlet	1	1	
16	55311-99004	GASKET, gear case 1	1	1	
17	55312-99000	GASKET, gear case 2	1	1	
18	55313-99000	GASKET, gear case	1	1	
19	56111-99002-01J	HOUSING, bearing	1	1	
20	09289-15001	OIL SEAL, bearing housing	1	1	15x30x9
21	08113-63020	BEARING	1	1	15x42x13
22	09280-50002	O RING, bearing housing	1	1	ID:50,d:3.1
23	09100-06020	BOLT, bearing housing	2	2	6x20
24	09162-06001	LOCK WASHER, bearing housing	2	2	
25-1	58111-99003-01T	PROPELLER (STD)	1	-	to 58111-99004-01T
25-2	58111-99004-01T	PROPELLER (STD)	-	1	2x210x140
26-1	58111-99720-01T	PROPELLER	1	-	to 58111-99721-01T
26-2	58111-99721-01T	PROPELLER	-	1	3x200x150 (F600)
27-1	58111-98720-01T	PROPELLER	1	-	to 58111-98721-01T
27-2	58111-98721-01T	PROPELLER	-	1	3x200x130 (F500)
28	58120-99026	BUSHING, propeller	1	1	
29	09202-05013	SHEAR PIN	1	1	5x27,to 09202-05020
30	58131-99000	NUT, propeller	1	1	
31	09204-03001	COTTER PIN, propeller	1	1	3.6x38.2

FIG.46

F - 4

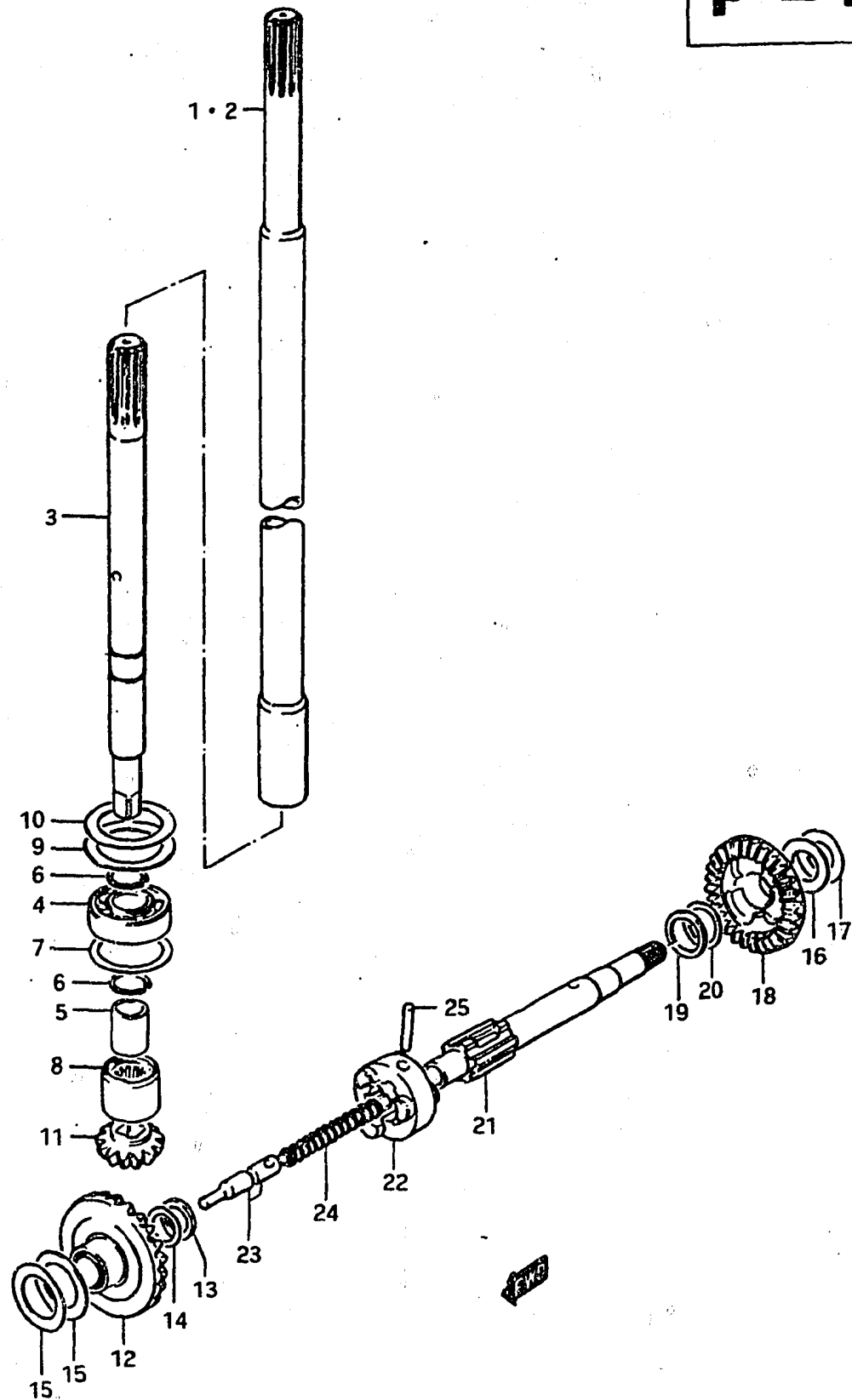

FIG.46 TRANSMISSION

Ref. No.	Part No.	Description	Q'ty		Remarks
			C	D	
1	57110-99105	SHAFT, drive	1	1	
2	57110-99206	SHAFT, drive	1	1	
3	57211-99003	SHAFT, pinion	1	1	S,L type,L:220
4	08113-62020	BEARING	1	1	
5	09180-12036	SPACER, pinion shaft	1	1	12x16x20
6	08331-31159	CIRCLIP	2	2	
7-1	08221-25353	SHIM, pinion shaft	AR(0~3)		T:1.5
7-2	08221-25354	SHIM, pinion shaft	AR(0~3)		T:0.2
8	09263-16007	BEARING, pinion shaft	1	1	16x20x20
9-1	08211-28382	THRUST WASHER, pinion shaft	AR(0~1)		T:1.5
9-2	08211-28381	THRUST WASHER, pinion shaft	AR(0~1)		T:1.0
10-1	08221-28383	SHIM, pinion shaft	AR(0~3)		T:0.1
10-2	08221-28384	SHIM, pinion shaft	AR(0~3)		T:0.2
11	57311-99001	PINION	1	1	NT:13
12	57510-99002	GEAR, forward	1	1	NT:25
13-1	08211-12202	THRUST WASHER, forward gear	AR(0~1)		T:1.5
13-2	08211-12203	THRUST WASHER, forward gear	AR(0~1)		T:2.0
14-1	08221-12203	SHIM, forward gear	AR(0~1)		T:0.1
14-2	08221-12204	SHIM, forward gear	AR(0~2)		T:0.2
15-1	08221-20303	SHIM, forward gear back	AR(0~1)		T:0.1
15-2	08221-20304	SHIM, forward gear back	AR(0~2)		T:0.2
15-3	08221-20305	SHIM, forward gear back	AR(0~1)		T:0.5
16	08211-15261	THRUST WASHER, propeller shaft	AR(0~1)		T:1.0
17-1	08221-15263	SHIM, propeller shaft	AR(0~1)		T:0.1
17-2	08221-15264	SHIM, propeller shaft	AR(0~2)		T:0.2
17-3	08221-15266	SHIM, propeller shaft	AR(0~1)		T:0.8

S type.....Transom 16"
L type.....Transom 22"

FIG.46

F - 5

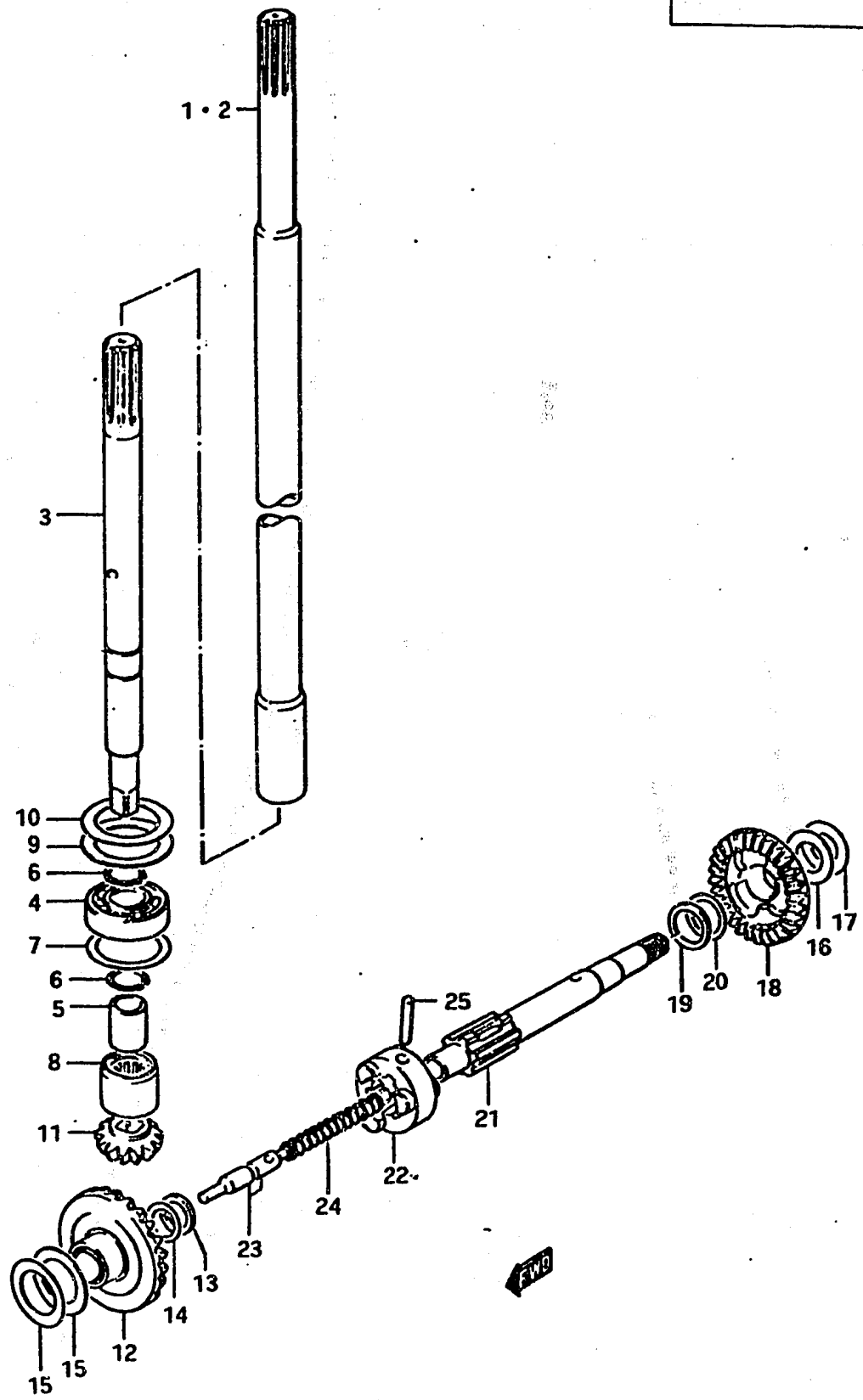

FIG.46 TRANSMISSION

Ref. No.	Part No.	Description	Q'ty		Remarks
			C	D	
18	57520-99400	GEAR, reverse	1	1	NT:29
19-1	08211-15202	THRUST WASHER, reverse gear	AR(0~1)		T:1.5
19-2	08211-15203	THRUST WASHER, reverse gear	AR(0~1)		T:2.0
20-1	08221-15203	SHIM, reverse gear	AR(0~1)		T:0.1
20-2	08221-15204	SHIM, reverse gear	AR(0~2)		T:0.2
21	57611-99003	SHAFT, propeller	1	1	from 57611-99002
22	57621-99004	SHIFTER, clutch	1	1	from 57621-99003
23	57630-99830	ROD SET, push	1	1	from 57631-99003
24	09440-07018	SPRING, push rod return	1	1	
25	09209-04008	PIN, clutch dog shifter	1	1	4x35.5

S type.....Transom 16"
L type.....Transom 22"

FIG.47

F - 6

FIG.47 ENGINE COVER

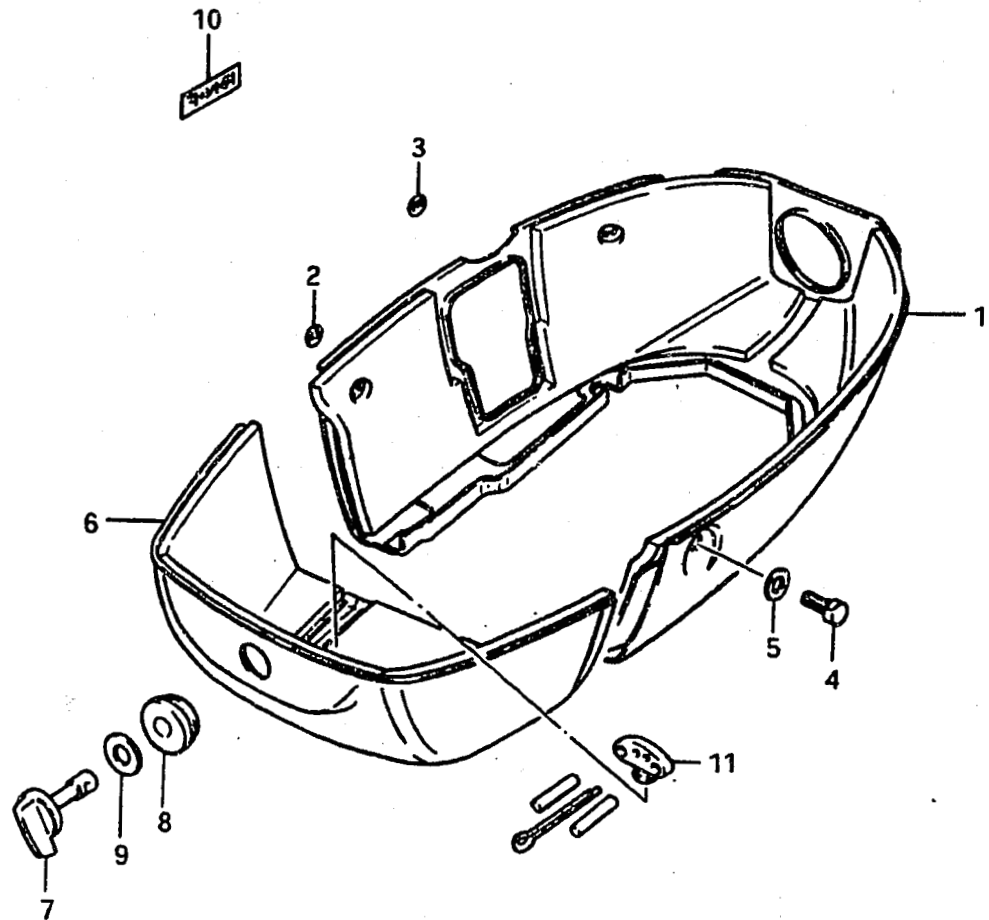

Ref. No.	Part No.	Description	Q'ty		Remarks
			C	D	
1	61110-98003-01J	COVER, engine lower	1	1	
2-1	61211-99600	MARK, fuel cock "ON"	1	-	to 61211-99601
2-2	61211-99601	MARK, fuel cock "ON"	-	1	
3-1	61212-99600	MARK, fuel cock "OFF"	1	-	to 61212-99601
3-2	61212-99601	MARK, fuel cock "OFF"	-	1	
4	09100-06018	BOLT, lower cover	4	4	6x12
5	09160-06015	WASHER, lower cover	4	4	6.5x11.5x0.8
6-1	61410-98002-01J	COVER, engine front	1	-	to 61410-98003-01J
6-2	61410-98003-01J	COVER, engine front	-	1	
7	61610-99020	FASTENER, engine cover	1	1	
8	61621-99000	BUSHING, fastener	1	1	
9	08322-21088	WASHER	1	1	
10-1	21131-96000	MARK, clutch shifting	1	-	
10-2	21131-96001	MARK, clutch shifting	-	1	to 21131-96002
11	61521-96000	HOLDER, shear pin	1	1	to 61521-98400

FIG. 48

F - 7

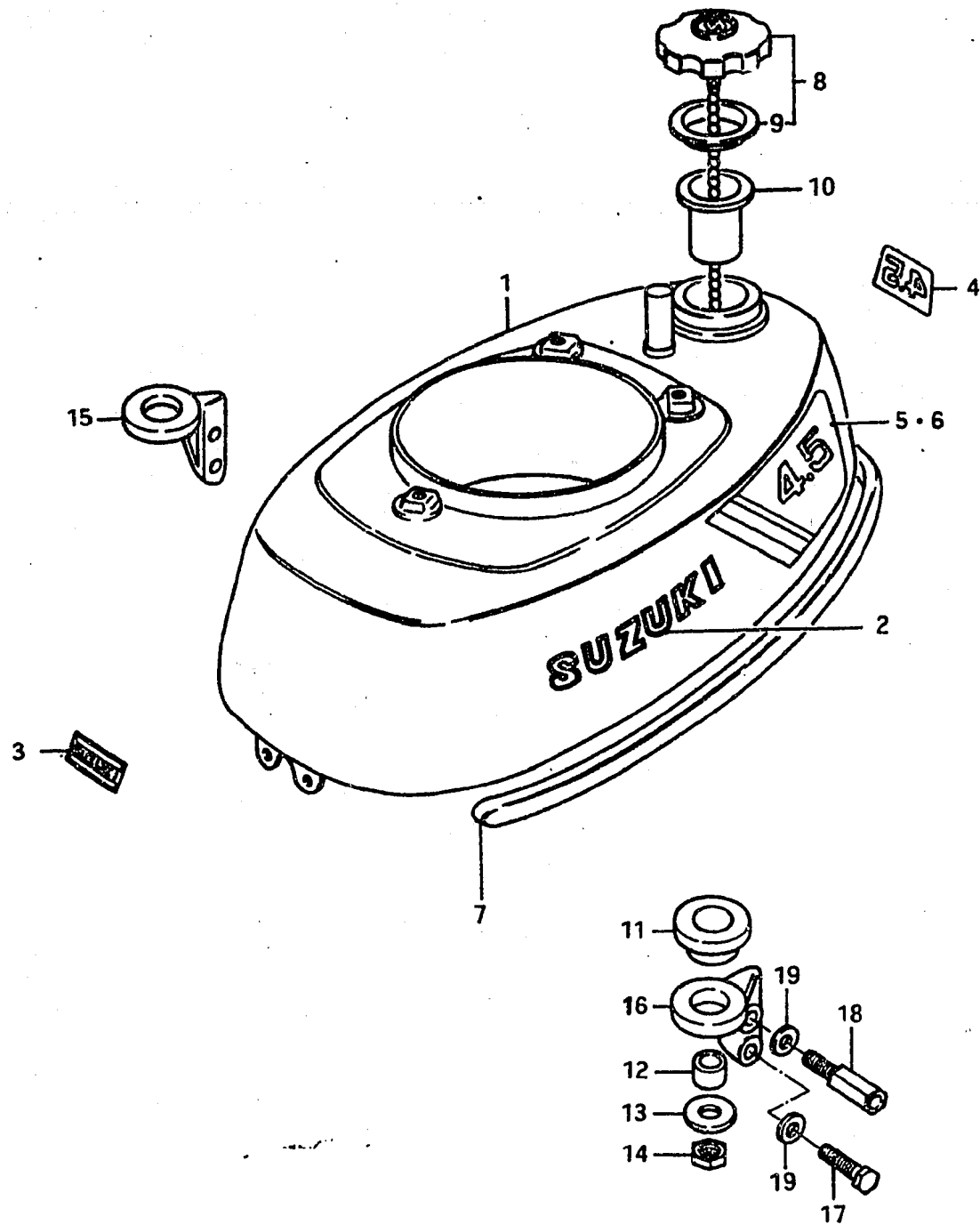

19

FIG. 48 FUEL TANK

Ref. No.	Part No.	Description	Q'ty		Remarks
			C	D	
1	65100-98850-01T	TANK ASSY, fuel	1	1	
2	61441-98400	•EMBKEM, tank side	2	2	to 61441-98500
3	61422-93300	•EMBLEM, front	1	1	
4-1	65325-98601	EMBLEM, tank rear	1	-	
4-2	65325-98002	EMBLEM, tank rear	-	1	
5-1	65328-98600	EMBLEM, tank side RH	1	-	
5-2	65328-98000	EMBLEM, tank side RH	-	1	
6-1	65338-98600	EMBLEM, tank side LH	1	-	
6-2	65338-98000	EMBLEM, tank side LH	-	1	
7	65350-98001	MOULDING, tank side	1	1	plastic
8-1	65501-98806	CAP ASSY, fuel tank	1	-	to 65510-98820
8-2	65510-98820	CAP ASSY, fuel tank	-	1	to 65510-98402
9	09168-32001	•GASKET, tank cap	1	1	32x48x2.5
10	65551-98001	FILTER, fuel	1	1	
11	09320-10002	CUSHION, tank rubber	4	4	
12	09180-06006	SPACER, tank cushion	4	4	6.5x10.5x11.5
13	09160-06046	WASHER	4	4	from 09160-06020 6.5x20x1.5
14	09159-06015	NUT, tank	4	4	
15	65611-98001	STAY, tank RH	1	1	
16	65621-98001	STAY, tank LH	1	1	
17	01107-08258	BOLT	2	2	
18	65631-98000	BOLT, tank stay	2	2	
19	08322-11088	WASHER	4	4	

FIG.49

F - 8

FIG.49 FUEL COCK

Ref. No.	Part No.	Description	Q'ty		Remarks
			C	D	
1	65341-98000	SPACER, fuel cock	1	1	
2	66100-98051	COCK ASSY, fuel	1	1	
3	44346-99050	•GASKET, cup	1	1	
4	66181-99050	•FILTER, cup	1	1	
5	66152-99050	•FILTER	1	1	
6	66141-99050	•GASKET, joint	1	1	
7	66251-98010	•CAP, fuel cock	1	1	
8	09343-05137	HOSE, fuel	1	1	L:500-180
9	09344-08004	HOSE, air vent drain	1	-	L:200
10	09401-08401	CLIP, fuel hose	2	2	to 09401-08403

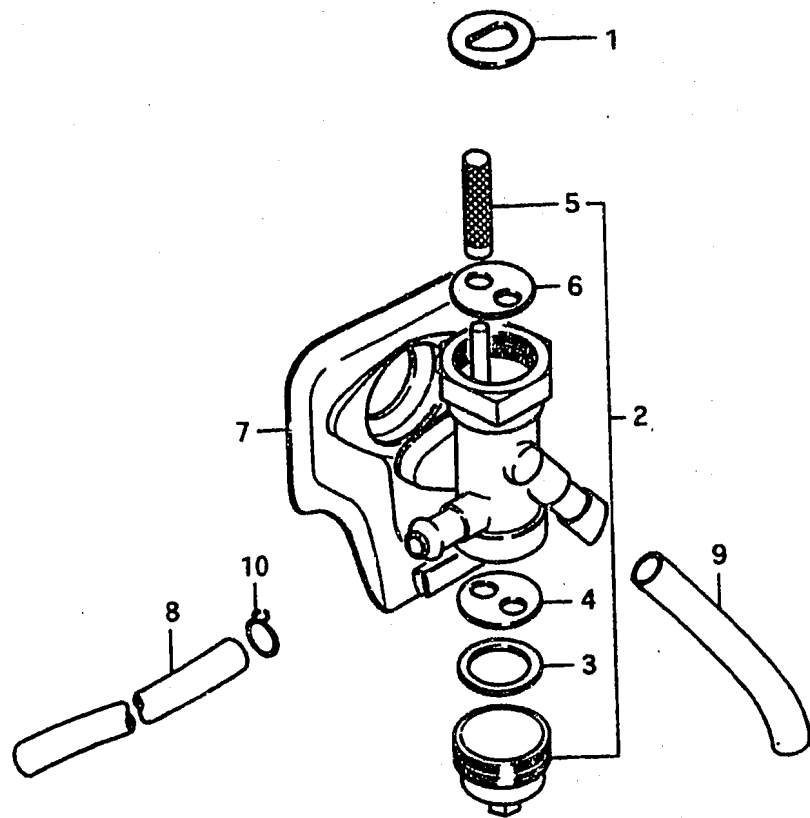
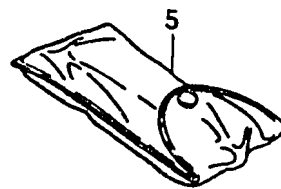
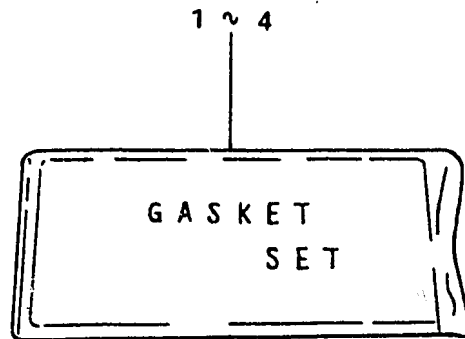

FIG.9

K - 11

FIG.9 OPT : GASKET / TOOL SET



Ref. No.	Part No.	Description	Q'ty	Remarks
1	11400-98840	GASKET SET (ENGINE)	1	DT3.5
2	11400-98820	GASKET SET (ENGINE)	1	DT4,DT4.5
3-1	11400-98830	GASKET SET (ENGINE)	1	DT5D, to 11400-98831
3-2	11400-98832	GASKET SET (ENGINE)	1	DT5F to 11400-98833 to 11400-98834
3-3	11400-98833	GASKET SET (ENGINE)	1	
4	11400-96820	GASKET SET (ENGINE)	1	DT7.5,DT9 to 11400-96821
5-1	09800-00128	TOOL SET (DT3.5~DT9)	1	to 09800-00805
5-2	09800-00178	TOOL SET (DT2)	1	to 09800-00805

FIG.10

K - 12

10

FIG.10 OPT : LIGHTING COIL, EMERGENCY SWITCH

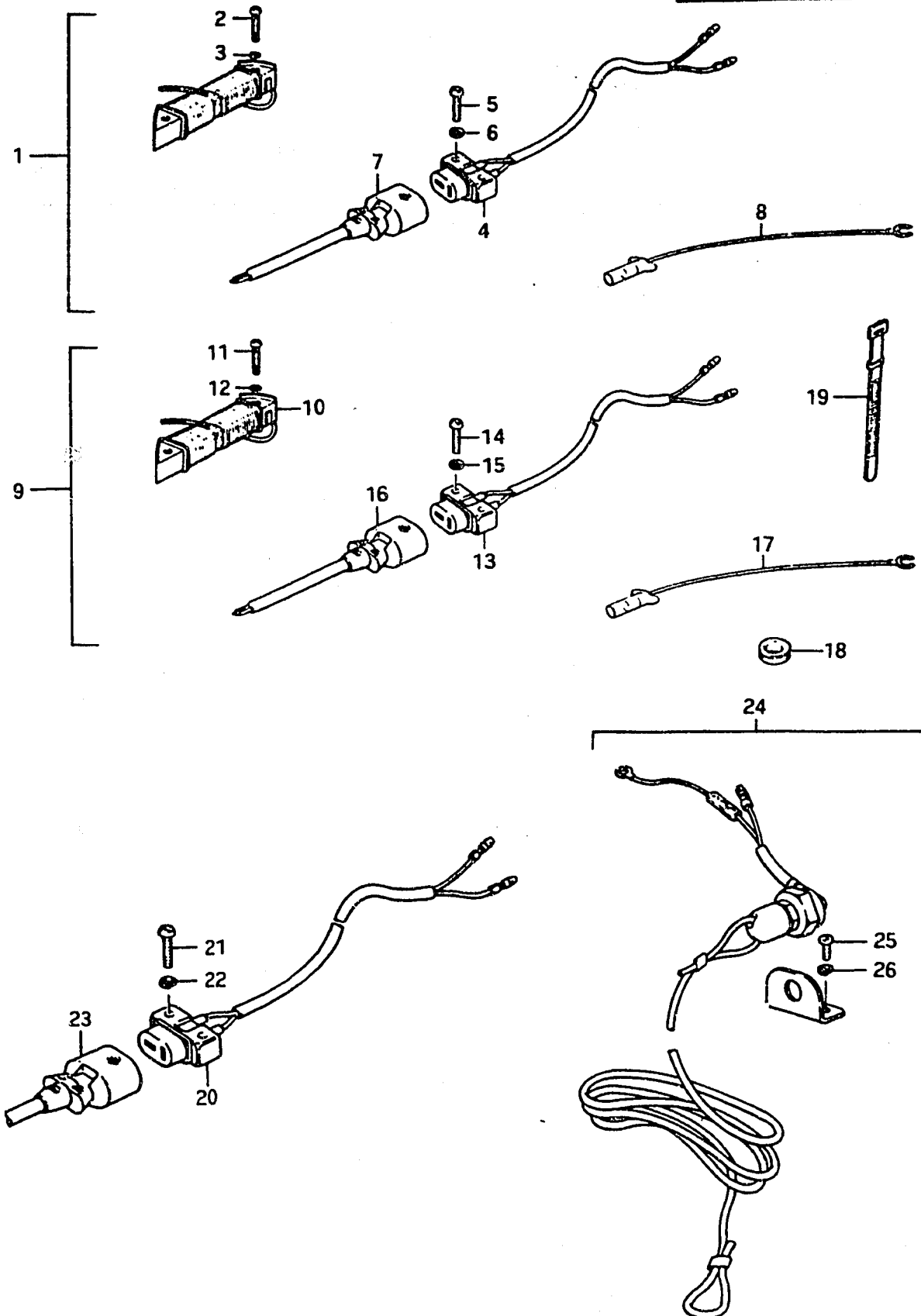

Ref. No.	Part No.	Description	Q'ty		Remarks
			2~9		
1	32200-98821	COIL SET, lighting to (32200-98300)+(39600-98300)	1		DT2 DT3.5 DT4,DT4.5
2	02112-05258	•SCREW	2		
3	08321-21058	•LOCK WASHER	2		
4	39601-96711	•SOCKET ASSY	1		
5	02112-04208	•SCREW	2		
6	08322-21048	•WASHER	2		
7	39602-99711	•PLUG ASSY, lighting	1		
8	36898-93300	•LEAD WIRE, earth	1		
9	32200-98832	COIL SET, lighting	1		DT5
10	32120-98520	•COIL, lighting	1		
11	02112-06258	•SCREW	2		
12	08321-21068	•LOCK WASHER	2		
13	39601-96711	•SOCKET ASSY	1		
14	02112-04258	•SCREW	2		
15	08322-21048	•WASHER	2		
16	39602-99711	•PLUG, lighting	1		
17	36898-93300	•LEAD WIRE, earth	1		
18	09308-10002	•GROMMET, lead wire	1		
19	09407-12402	•CLAMP, lead wire	1		
20	39601-96711	•SOCKET ASSY	1		DT7.5,DT9
21	02112-04208	•SCREW	2		
22	08322-21048	•WASHER	2		
23	39602-99711	•PLUG, lighting	1		DT2~DT9
24-1	37800-93812	SWITCH SET, emergency from 37800-93811	1		
24-2	37800-93813	SWITCH SET, emergency from 37800-93812	1		
25	09125-04011	•SCREW	2		
26	09162-04002	•LOCK WASHER	2		

FIG.14

L - 2

FIG.14 OPTIONAL

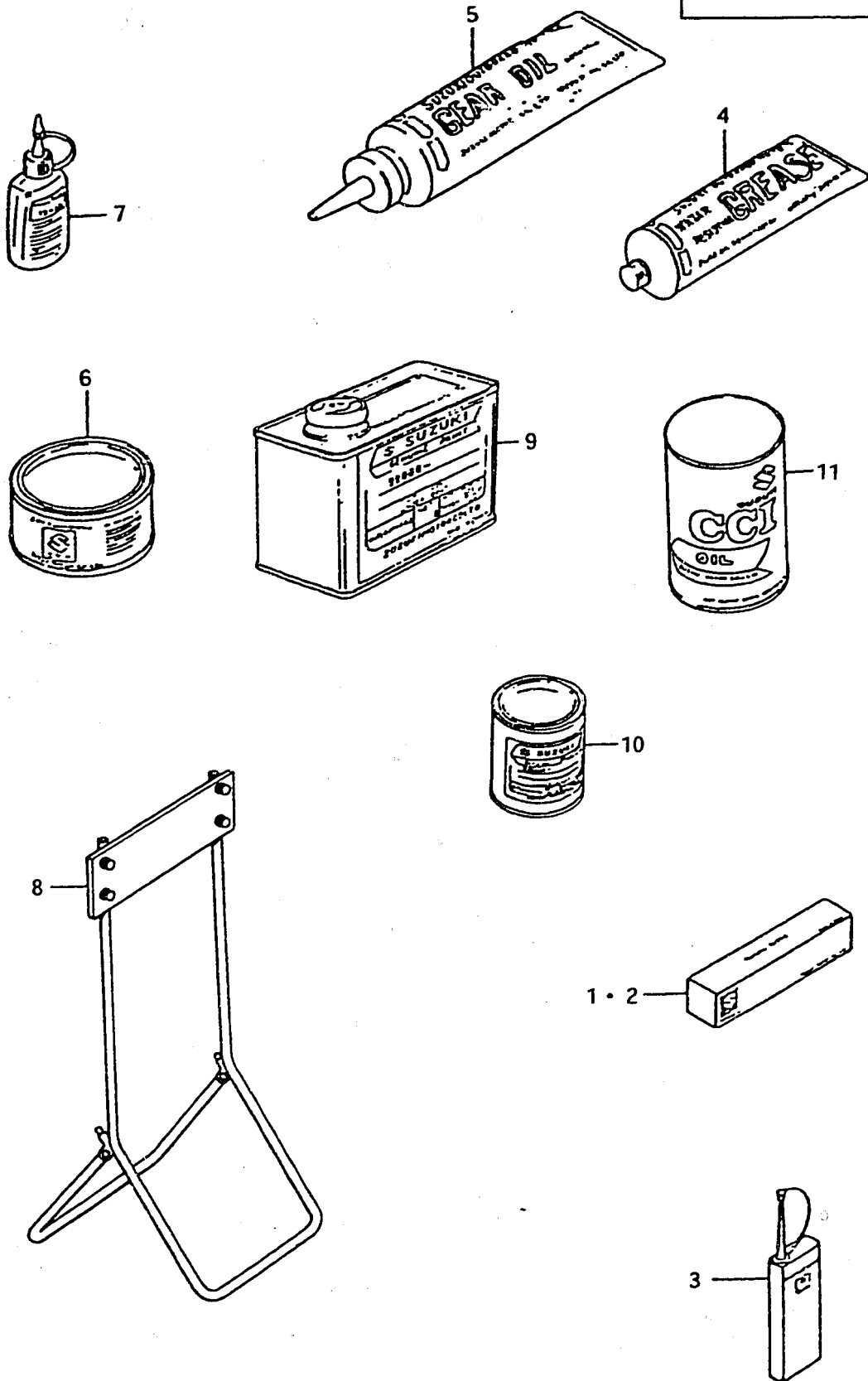

Ref. No.	Part No.	Description	Q'ty	Remarks
1	99000-31030	GASKET, liquid	1	for crankcase,100g
2	99000-31050	GASKET, liquid	1	for gear case,100g
3	99000-32040	CEMENT, thread lock	1	200g
4-1	99000-25160	GREASE, water resistant	1	250g
4-2	99000-25170	GREASE, water resistant	1	50g
5	99000-22540	GEAR OIL, outboard motor	1	400cc
6	99000-25010	SUZUKI SUPER GREASE A	1	450g,for crank oil seal
7	99000-32030	SUZUKI LOCK SUPER	1	50g (1303B)
8	09914-39911	HANGER, engine	1	
9-1	99000-10105-01T	PAINT (500g)	1	
9-2	99000-10205-01J	PAINT (500g)	1	
10-1	99000-10109-01T	PAINT (90g)	1	
10-2	99000-10209-01J	PAINT (90g)	1	
11-1	99000-21460	CCI OIL (1ℓx24,Mitsubishi)	1	
11-2	99000-21145	CCI OIL (1ℓx24,Shell)	1	
11-3	99000-21021	CCI OIL (4ℓx6)	1	
11-4	99000-21150	CCI OIL (200ℓ)	1	
11-5	99000-21250	CCI SUPER OIL (1ℓx24)	1	
11-6	99000-21260	CCI SUPER OIL (4ℓx6)	1	