



SUZUKI MARINE

Parts Book

DT 30 (1986-1987)



1703 Hwy 35 So., Laurence Harbor, NJ 08879

(732) 264-7176

(800) 338-0645 FAX (732) 264-2472

www.brownspoint.com

When it becomes necessary to replace parts on SUZUKI OUTBOARD MOTORS, always use SUZUKI GENUINE PARTS which have passed a strict inspection which guarantees quality and performance.

This parts catalogue covers the list of all service parts for SUZUKI DT30R VG, DT30R VH.

INSTRUCTIONS FOR QUOTING THE CATALOGUE

1. DIMENSIONS

Dimensions of the parts in this catalogue are indicated in unit millimeters.

2. ABBREVIATIONS

Abbreviations used in this catalogue are as follows:

AR	: As required	NT	: Number of teeth
ASSY	: Assembly	OPT	: Optional
E.No.	: Engine number	OS	: Over size
F.No.	: Frame number	STD	: Standard
d	: Diameter of material	T	: Thickness
ID	: Inside diameter	US	: Under size
OD	: Outside diameter	W	: Width
L	: Length	S,L,UL,LL	: Transom type
LH	: Left hand side		
RH	: Right hand side		
-123456	: Up to F.No.03001-723456		
123456~	: From F.No.03001-723456		
12 x 34 x 5.6Figures in the description column show the dimensions of parts.		
ID OD T(or W,L)			

3. INNER PARTS OF ASSEMBLY

Parts number that have a period (.) mark in front of the part description on a text page are separately serviced parts of the assembly.

4. MODIFICATION NOTICE

A parts bulletin will be sent to you on all occasions when changes in parts occur, including interchangeable modifications between new parts and old ones.

5. NOTE

- 5-1. There are some different parts from those of production models among spare parts for the administrative reasons and common use of them with other models.
- 5-2. In respect of rubber hoses and vinyl tubes, please be sure to use them by cutting off according to the length mentioned on parts catalogue or what is actually required on the vehicle.
- 5-3. Note that the drawings on the illustration page are for ready reference of spare parts number, not to be used as an assembly manual. When assembling, use "SUZUKI SERVICE MANUAL".

6. ENGINE NUMBER

DT30R VG : ** 03001-614522~
DT30R VH : ** 03001-719001~

7. COLOR

Color No.	Color description
02M	Arctic Silver
01T	Francois White-2

FIG.1

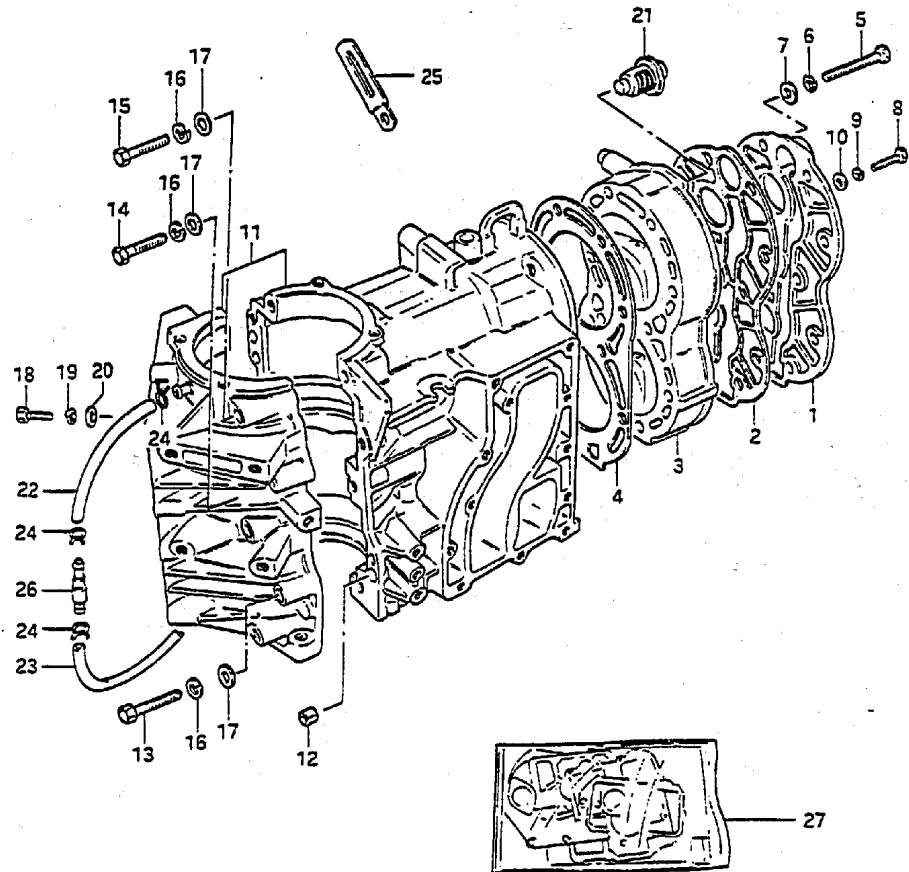

FIG.1 (B- 2) CYLINDER

REF.NO.	PART NO.	DESCRIPTION	Q'TY	REMARKS
1	11161-96302-02M	COVER, cylinder head	1	
2	11162-96302	GASKET	1	
3-1	11111-96302-02M	CYLINDER HEAD	1	~617845
3-2	11111-96303-02M	CYLINDER HEAD	1	617846~
4	11141-96302	GASKET	1	
5	01107-08652	BOLT	10	
6	08321-21082	LOCK WASHER	10	
7	08322-11082	WASHER	10	
8	01107-06252	BOLT	2	
9	08321-21062	LOCK WASHER	2	
10	08322-21062	WASHER	2	
11	11301-96306-02M	CYLINDER ASSY	1	
12	04211-09109	.PIN	2	
13	01107-08552	.BOLT	4	
14	01107-08452	.BOLT	2	
15	01107-08602	.BOLT	2	
16	08321-21082	.LOCK WASHER	8	
17	08322-11082	.WASHER	8	
18	01107-06252	.BOLT	4	
19	08321-21062	.LOCK WASHER	4	
20	08322-21062	.WASHER	4	
21	17670-93962	THERMOSTAT	1	
22	09343-03051	HOSE (3.1x6.8x330)	1	L:330+180
23	09343-03051	HOSE (3.1x6.8x330)	1	L:330+180
24	09401-06403	CLIP	4	
25	09404-06204	CLAMP (L:80)	2	
26	16710-96300	CHECK VALVE	1	
27	11400-96847	GASKET SET	1	OPT

SWD

FIG.2

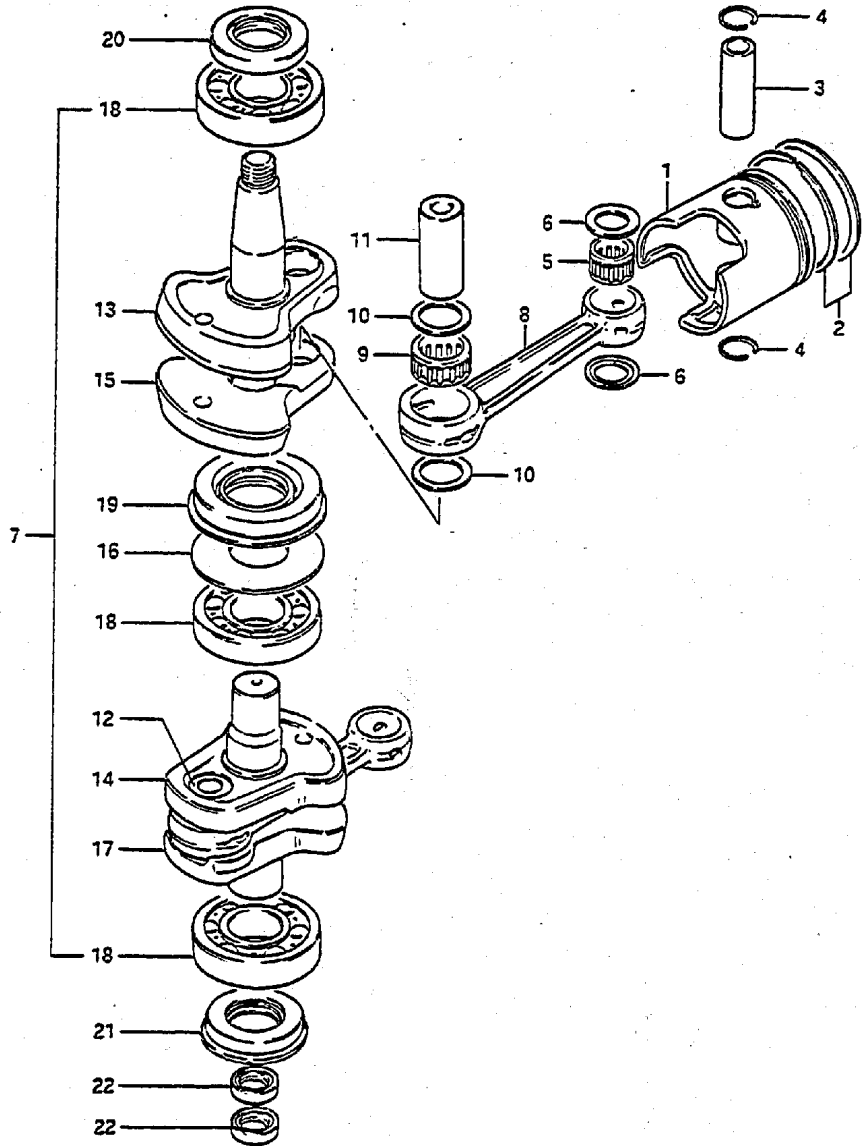

FIG.2 (B- 3) CRANKSHAFT

REF.NO.	PART NO.	DESCRIPTION	Q'TY	REMARKS
1-1	12110-96303	PISTON, STD	2	
1-2	12110-96353-025	PISTON, OS:0.25	2	OPT
1-3	12110-96353-050	PISTON, OS:0.50	2	OPT
2-1	12140-96301	RING SET, piston, STD	2	
2-2	12140-96351-025	RING SET, piston, OS:0.25	2	OPT
2-3	12140-96351-050	RING SET, piston, OS:0.50	2	OPT
3	12151-92501	PIN, piston	2	
4	09381-18002	SNAP RING	4	
5	09263-18016	BEARING (18x23x22)	2	
6	09169-18001	WASHER	4	
7	12200-96306	CRANKSHAFT ASSY	1	
8	12161-96300	.ROD, connecting	2	
9	09263-24016	.BEARING (24x32x20)	2	
10	09181-24001	.WASHER (24x31.5x1)	4	
11	12211-96311	.PIN, crank upper	1	
12	12211-96301	.PIN, crank lower	1	
13	12221-96304	.CRANKSHAFT, upper	1	
14	12232-96303	.WHEEL, middle under	1	
15	12231-96302	.WHEEL, middle upper	1	
16	09160-50002	.WASHER (50x77x1)	1	
17	12240-96305	.CRANKSHAFT, under	1	
18	09262-30055	.BEARING (30x72x19)	3	
19	09289-38013	.OIL SEAL	1	
20	09283-30011	OIL SEAL (30x55x10)	1	
21	09283-30042	OIL SEAL (30x55x10)	1	Flanged type
22	09282-15004	OIL SEAL (14.7x25x7)	2	

FIG.3

FIG.3 (B- 4) INLET CASE - EXHAUST COVER

Q'TY

REF.NO.	PART NO.	DESCRIPTION	Q'TY	REMARKS
1	01517-06252	BOLT	8	
2	08316-16062	NUT	2	
3	12481-96301-02M	CASE, inlet	1	
4	13125-93000	GASKET, carburetor	1	
5	01411-08202	STUD BOLT	2	
6	01421-06202	STUD BOLT	2	
7	13150-96300	REED VALVE ASSY	1	
8	13152-96300	.STOPPER, reed valve	4	
9	13153-96300	.REED, valve	4	
10	02112-03068	.SCREW	12	
11	08321-21067	.LOCK WASHER	12	
12	02122-06167	SCREW	1	
13	08316-16082	NUT	2	
14	14151-96300	GASKET, exhaust cover	2	
15	14131-96301	PLATE, exhaust	1	
16-1	14141-96300-02M	COVER, exhaust	1	-616281
16-2	14141-96301-02M	COVER, exhaust	1	616282-
17	01517-06252	BOLT	12	
18	13811-96300	CASE, silencer	1	
19	02112-06402	SCREW	3	
20	08322-21062	WASHER	3	

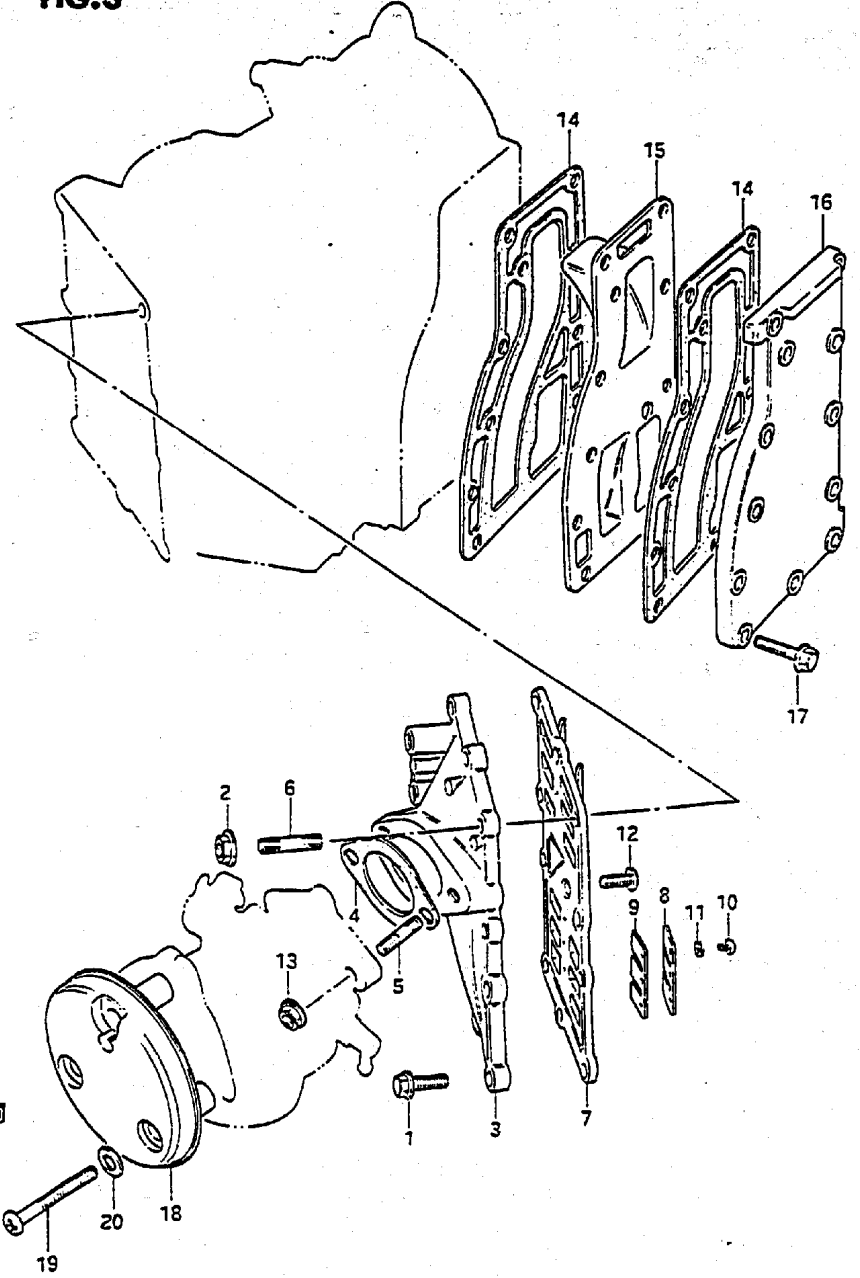
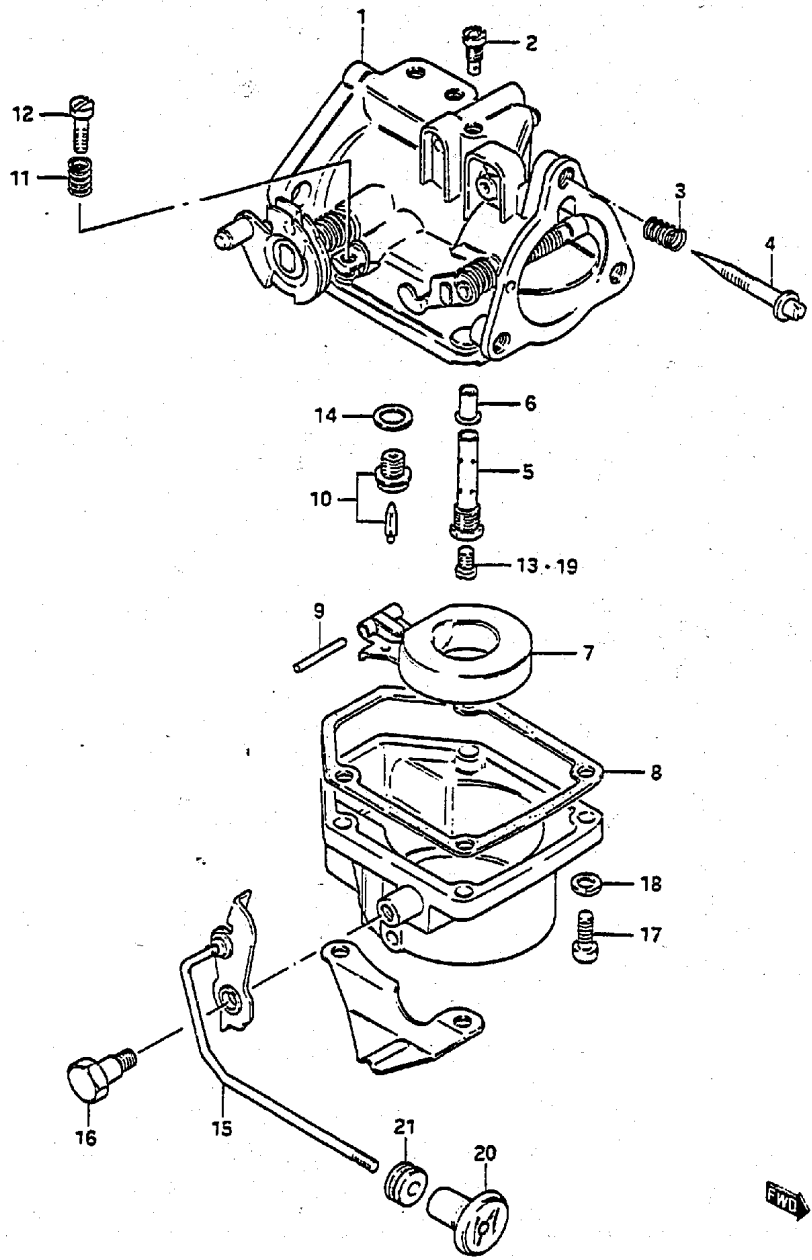

FIG.4

FIG.4 (B- 5) CARBURETOR



REF.NO.	PART NO.	DESCRIPTION	Q'TY	REMARKS
1	13200-96304	CARBURETOR ASSY	1	
2	09492-85001	.JET, air (85)	1	
3	13271-93311	.SPRING, air screw	1	
4	13269-93311	.SCREW, pilot air	1	
5	13236-96300	.NOZZLE	1	
6	13237-94400	.NOZZLE	1	
7	13250-93012	.FLOAT	1	
8	13251-93310	.GASKET, float chamber	1	
9	13254-93010	.PIN, float	1	
10	13370-28110	.VALVE ASSY, needle	1	
11	13268-96110	.SPRING, throttle stop	1	
12	13534-96300	.SCREW, throttle stop	1	
13	09491-32006	.JET, main (160)	1	
14	13392-58600	.GASKET, valve seat	1	
15	13681-96300	.LEVER, choke	1	
16	13682-96300	.BOLT	1	
17	02112-05208	.SCREW	4	
18	08321-21057	.LOCK WASHER	4	
19-1	09491-34004	JET, main (170)	1	OPT
19-2	09491-33004	JET, main (165)	1	OPT
19-3	09491-31003	JET, Main (155)	1	OPT
20	13631-93500	KNOB, starter	1	
21	09305-04005	BUSH	1	

FIG.5

FIG.5 (B- 6) UPPER OIL SEAL HOUSING

Q'TY

REF.NO.	PART NO.	DESCRIPTION	Q'TY	REMARKS
1	11411-96301	HOUSING, upper oil seal	1	
2	11413-96300	GASKET	1	
3	02122-06208	SCREW	4	
4	31911-96302-02M	BRACKET, starter	1	
5	01107-08252	BOLT	4	
6	08321-21082	LOCK WASHER	4	
7	08322-11082	WASHER	4	

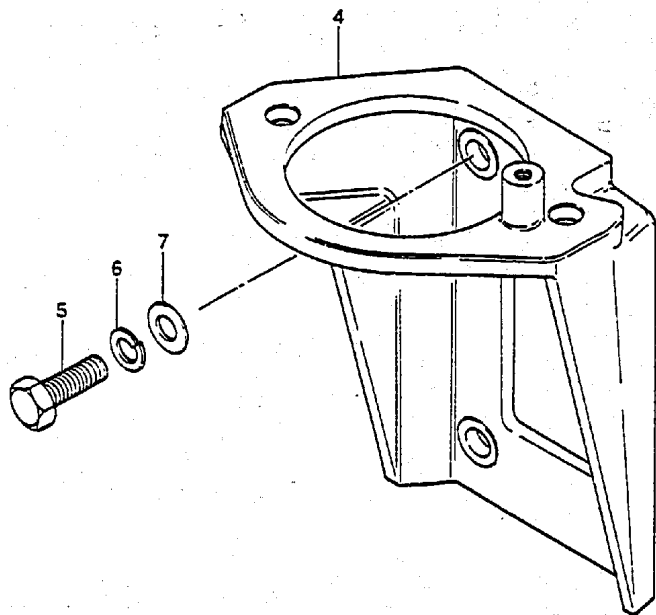
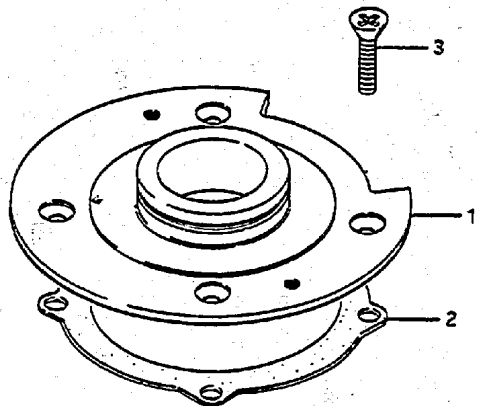

FWD

FIG.6

FIG.6 (B- 7) FUEL PUMP

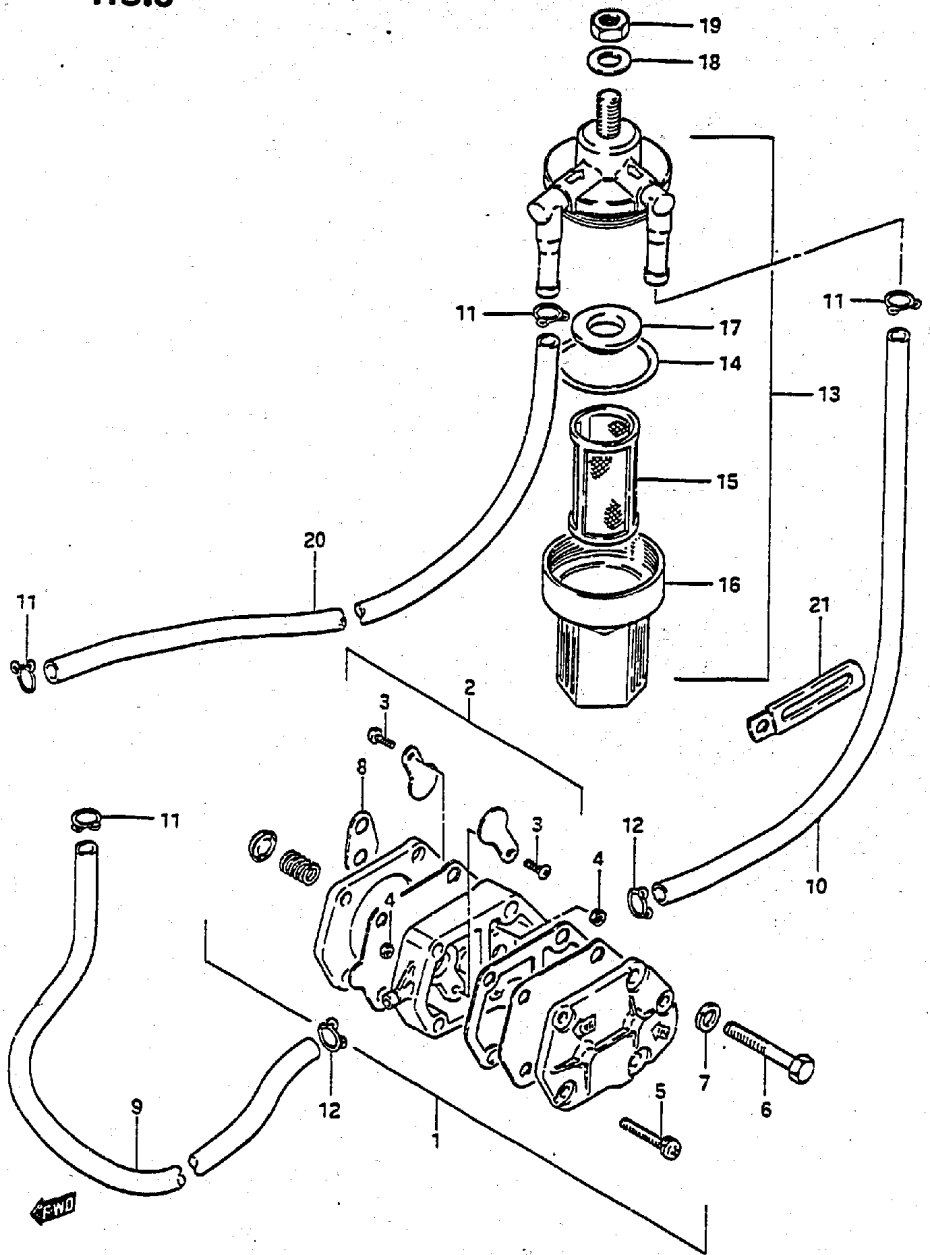

REF.NO.	PART NO.	DESCRIPTION	Q'TY	REMARKS
1	15100-94301	PUMP ASSY, fuel	1	
2	15170-94311	.DIAPHRAGM SET	1	
3	15183-94301	.SCREW	2	
4	15186-94300	.NUT	2	
5	15851-94300	.SCREW	3	
6	01107-06402	BOLT	2	
7	08321-21062	LOCK WASHER	2	
8	15321-99700	GASKET	1	
9	09343-05277	HOSE (5x9x540)	1	L:540+195
10	09343-05277	HOSE (5x9x540)	1	L:540+195
11	09401-08410	CLIP	4	
12	15331-94300	CLIP	2	
13	15410-93400	FILTER, fuel	1	
14	15415-93400	.O RING	1	
15	15412-93400	.STRAINER	1	
16	15413-93400	.CUP	1	
17	15416-93400	.PACKING	1	
18	08322-21082	WASHER	1	
19	08310-22082	NUT	1	
20	09343-05277	HOSE (5x9x540)	1	L:540+320
21	09404-06204	CLAMP	1	

FIG.7

FIG.7 (B- 8) WATER PUMP

Q'TY

REMARKS

REF.NO.	PART NO.	DESCRIPTION	Q'TY	REMARKS
1	17411-94400	CASE, water pump	1	
2-1	17431-96310	TUBE, water pump seal (S)	1	
2-2	17431-96300	TUBE, water pump seal (L)	1	
3	17432-96300	GROMMET, seal tube	2	
4	17461-96301	IMPELLER, water pump	1	
5	17471-94400	PANEL, under	1	
6	17472-96301	GASKET, pump case lower	1	
7-1	17560-96311	TUBE, water (S)	1	
7-2	17560-96301	TUBE, water (L)	1	
8	17563-96301	.GROMMET, upper (1)	1	
9	17564-96301	.GROMMET, upper (2)	1	
10	17565-96300	GROMMET, middle	1	
11	17566-96302	GROMMET, lower	1	
12	09108-06007	STUD BOLT	4	
13	09140-06004	NUT	4	
14	09162-06006	LOCK WASHER	4	
15	09420-04006	KEY	1	
16	56130-96301-02M	HOUSING, drive shaft bearing	1	
17	09265-17002	.BEARING	1	
18	09289-17004	.OIL SEAL	1	
19	25214-96302	.BUSH, shifting rod	1	
20	09100-06103	BOLT	2	
21	09162-06001	LOCK WASHER	2	
22	09280-50005	O RING	1	
23	17400-96350	KIT, water pump repair	1	OPT

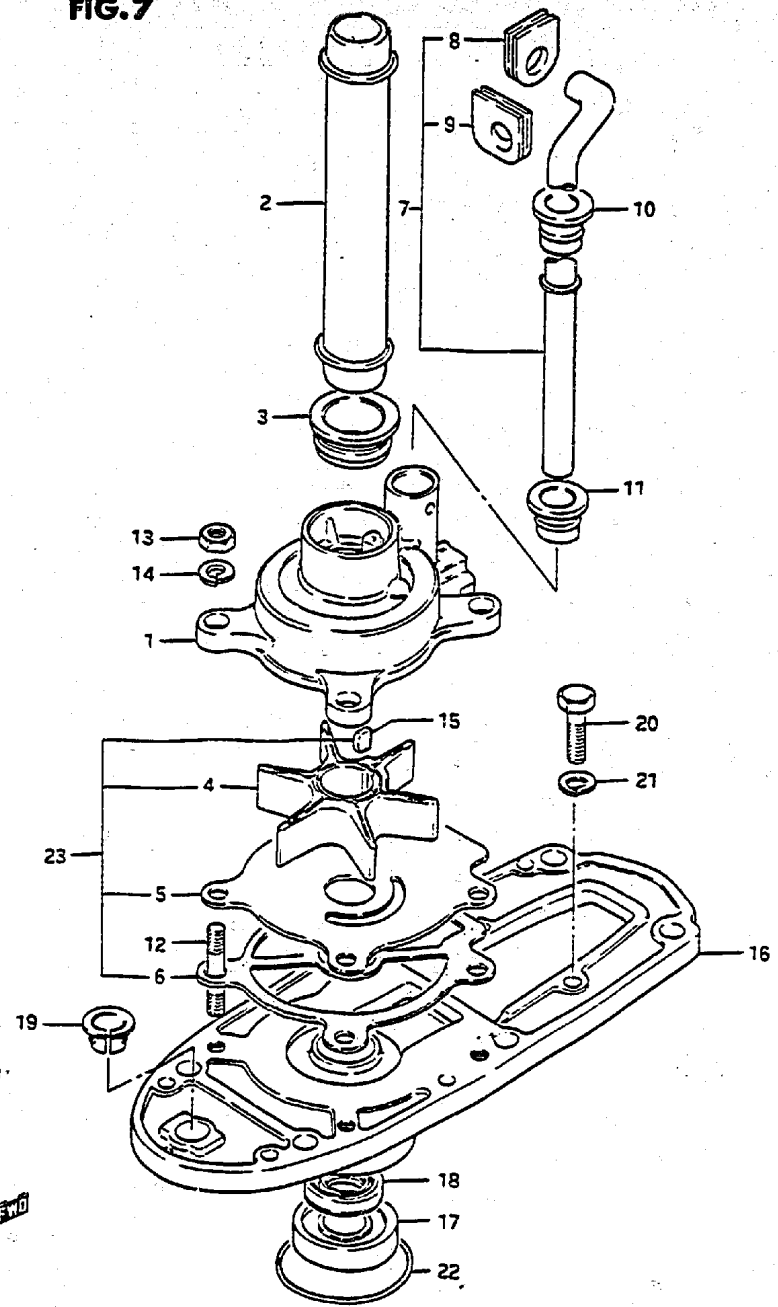

FIG. 8

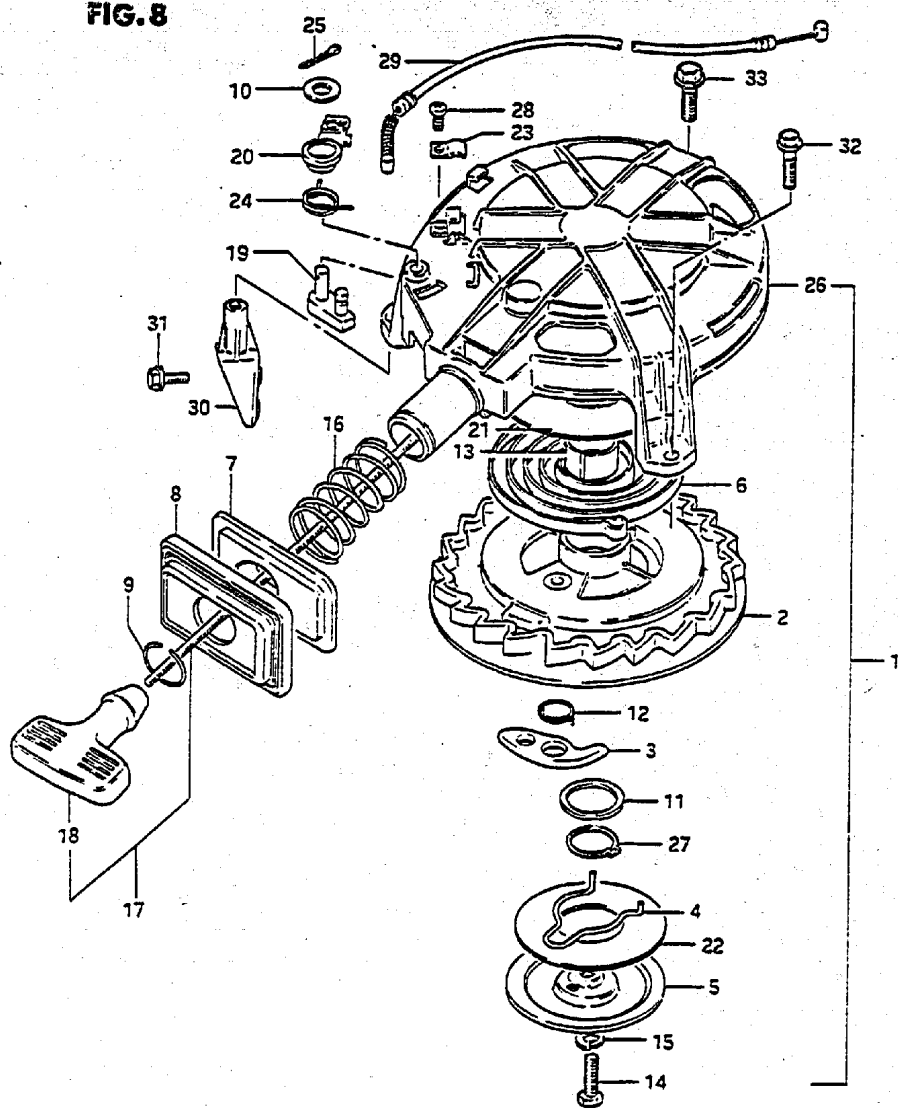

FIG. 8 (B- 9) RECOIL STARTER

Q'TY

REF.NO.	PART NO.	DESCRIPTION	REMARKS
1	18100-96306	STARTER ASSY, recoil	1
2	18120-96301	.REEL	1
3	18131-96301	.RATCHET	1
4	18153-96300	.SPRING	1
5	18151-96301	.PLATE	1
6	18142-96300	.SPRING	1
7	18191-95202	.PLATE	1
8	18192-95204	.RUBBER, protector	1
9	18195-95200	.RING	1
10	18335-96300	.WASHER	1
11	18162-96300	.WASHER	1
12	18155-96301	.SPRING	1
13	18124-96300	.BUSH	1
14	18332-96300	.BOLT	1
15	08321-31067	.LOCK WASHER	1
16	18196-96301	.SPRING, protector	1
17	18200-95203	.GRIP ASSY	1
18	18210-93001	..GRIP	1
19	18281-96300	.LEVER, stopper	1
20	18282-96300	.ARM, stopper	1
21	18144-96300	.SPACER	1
22	18136-96300	.SPACER	1
23	18291-96300	.HOLDER, cable	1
24	18284-96300	.SPRING	1
25	18348-96300	.PIN	1
26	18111-96301	.CASE, starter	1
27	18255-96300	.SNAP CLIP	1
28	18342-96300	.SCREW	1
29	18290-96301	CABLE, NSI	1
30	18711-96303-02M	BRACE, recoil starter STBD	1
31	01537-06202	BOLT	2
32	01537-06252	BOLT	2
33	01537-08252	BOLT	1

FIG.10

FIG.10 (C- 3) THROTTLE CONTROL

Q'TY

REMARKS

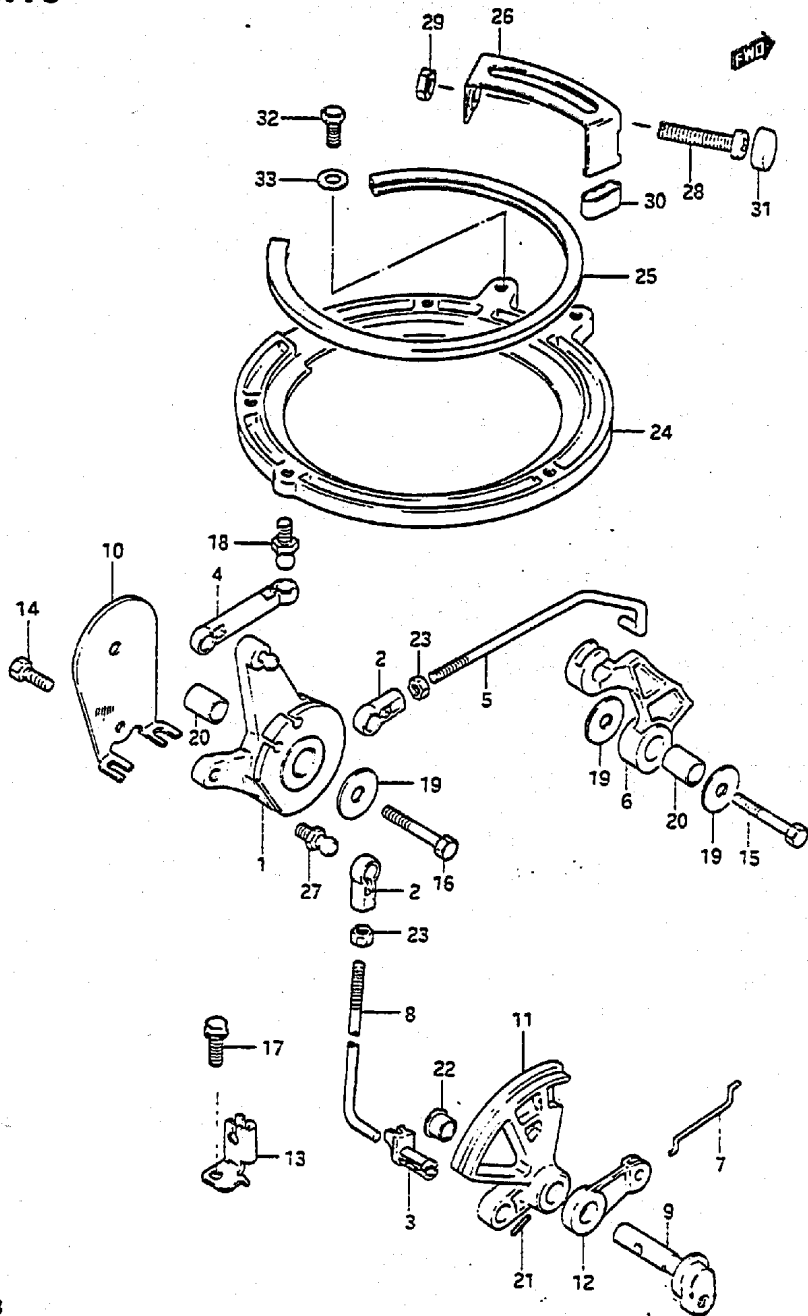

REF.NO.	PART NO.	DESCRIPTION	Q'TY	REMARKS
1	19121-96301	LEVER, throttle control	1	
2	19131-95502	CONNECTOR, throttle lever	2	
3	19131-96300	RETAINER, rod connector	1	
4	19132-95500	CONNECTOR	1	
5	19135-96301	ROD	1	
6	19141-96301	CAM, throttle	1	
7	19654-96300	ROD	1	
8	19656-96300	ROD	1	
9	19720-96302	SHAFT, remo-con throttle	1	
10	19761-96300	STAY, throttle cable	1	
11	19811-96301-02M	LIMITER, throttle	1	
12	19851-96301	LEVER, NSI	1	
13	19861-96301	STAY, NSI cable	1	
14	09100-06131	BOLT	1	
15	09100-06083	BOLT (6x30)	1	
16	09100-06083	BOLT (6x30)	1	
17	09103-06049	BOLT (6x12)	1	
18	09119-05010	BOLT	1	
19	09160-06046	WASHER (6.5x20x1.5)	3	
20	09180-06105	SPACER (6.1x10x14)	2	
21	09205-04002	SPRING PIN	1	
22	09306-10001	BUSH	1	
23	08310-11052	NUT	2	
24	19151-96300-02M	RETAINER, stator	1	
25	19161-94301	SPACER, stator	1	
26	19172-96301	STOPPER, stator	1	
27	09119-05010	BOLT	1	
28	09139-06015	SCREW	1	
29	09140-06004	NUT	1	
30	09320-07006	CUSHION	1	
31	09329-06002	CUSHION	1	
32	01107-05102	BOLT	2	
33	08322-21052	WASHER	2	

FIG. 11

FIG.11 (C- 4) STARTING MOTOR

Q'TY

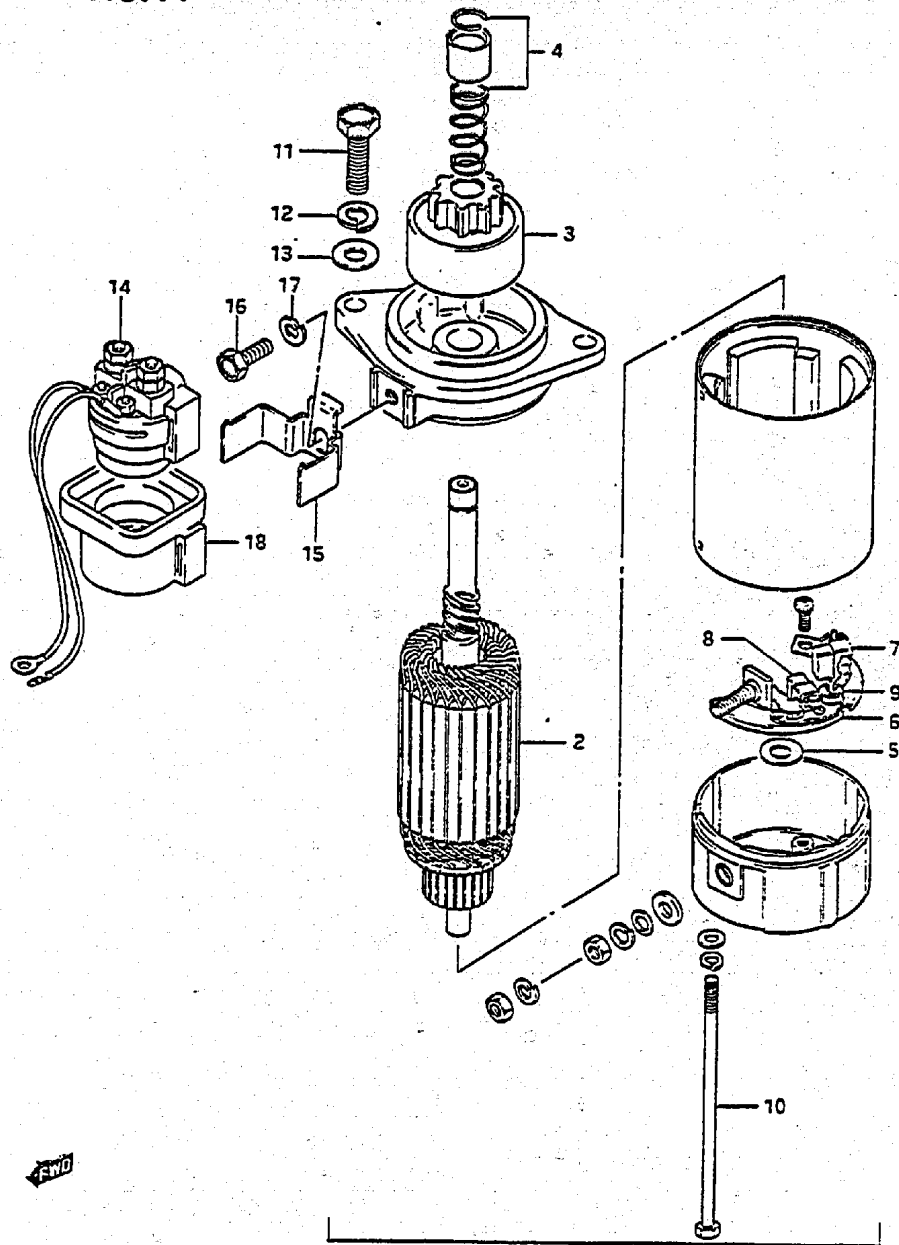

REF.NO.	PART NO.	DESCRIPTION	Q'TY	REMARKS
1	31100-96311	MOTOR ASSY, starter	1	
2	31310-96300	.ARMATURE	1	
3	31320-96300	.PINION	1	
4	31312-96300	.STOPPER SET, pinion	1	
5	31360-96300	.WASHER	1	
6	31173-96301	.HOLDER ASSY, brush	1	
7	31131-96300	..BRUSH (+)	1	
8	31132-96300	..BRUSH (-)	1	
9	31135-96300	..SPRING	2	
10	31281-93340	.BOLT	2	
11	01107-08252	BOLT	2	
12	08321-21082	LOCK WASHER	2	
13	08322-11082	WASHER	2	
14	31800-94400	RELAY, starter	1	
15	31805-96350	BRACKET, starter relay	1	
16	01107-06166	BOLT	1	
17	08321-21067	LOCK WASHER	1	
18	38422-94510	DAMPER, starter relay	1	

← RWD

FIG. 12

FIG.12 (C- 5) MAGNETO

Q'TY

REMARKS

REF.NO.	PART NO.	DESCRIPTION	Q'TY	REMARKS
1	32101-96340	STATOR ASSY	1	
2	32120-96300	.COIL, lighting	1	
3	02112-05252	.SCREW	2	
4	08321-21052	.LOCK WASHER	2	
5	32140-96300	.COIL, ignition	1	
6	02112-05202	.SCREW	2	
7	08321-21052	.LOCK WASHER	2	
8	32150-96310	.SENSOR, ignition	1	
9	02112-04122	.SCREW	2	
10	08321-21042	.LOCK WASHER	2	
11	32102-96380	FLYWHEEL	1	
12	02122-05122	SCREW	3	
13	08341-31049	KEY	1	
14	09160-18011	WASHER (18.5x35x4)	1	
15	08310-22182	NUT	1	

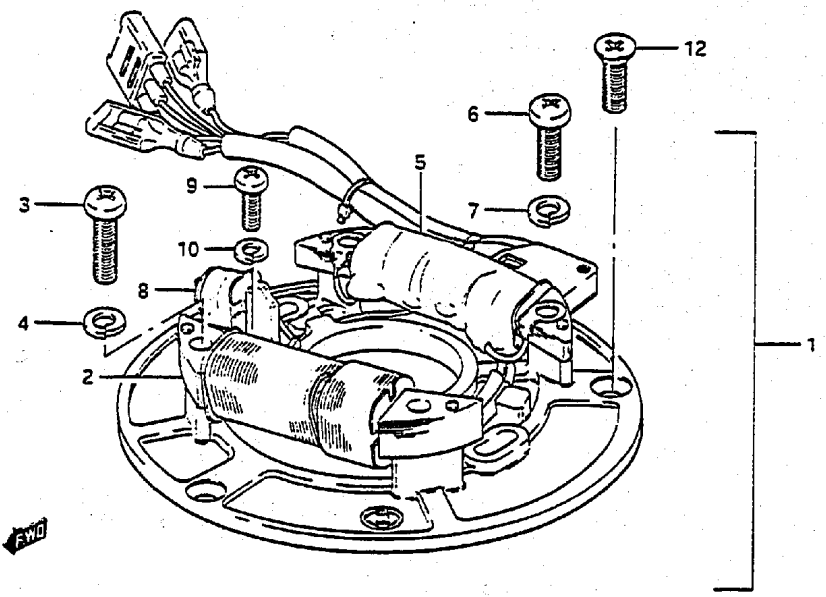
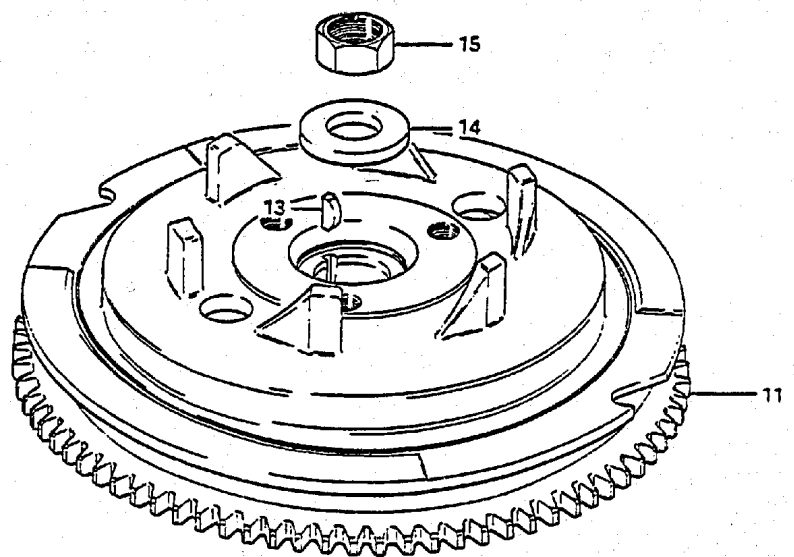

FIG.14

FIG.14 (C- 7) ELECTRICAL

REF.NO.	PART NO.	DESCRIPTION	Q'TY	REMARKS
1	36619-96304	COVER, wiring harness	1	
2	09103-06050	BOLT (6x16)	2	
3	38423-95501	TUBE, wiring harness (L:150)	1	
4	36740-95252	FUSE CASE ASSY	1	
5	09481-20001	.FUZE (20A)	1	
6	33810-96305	CABLE, starter	1	
7	33811-96300	GROMMET, starter cable	1	
8	33815-94500	PROTECTOR, cable	1	
9	09103-06049	BOLT	1	
10	33816-96300	CLAMP, starter cable	1	
11	03242-06259	SCREW	1	

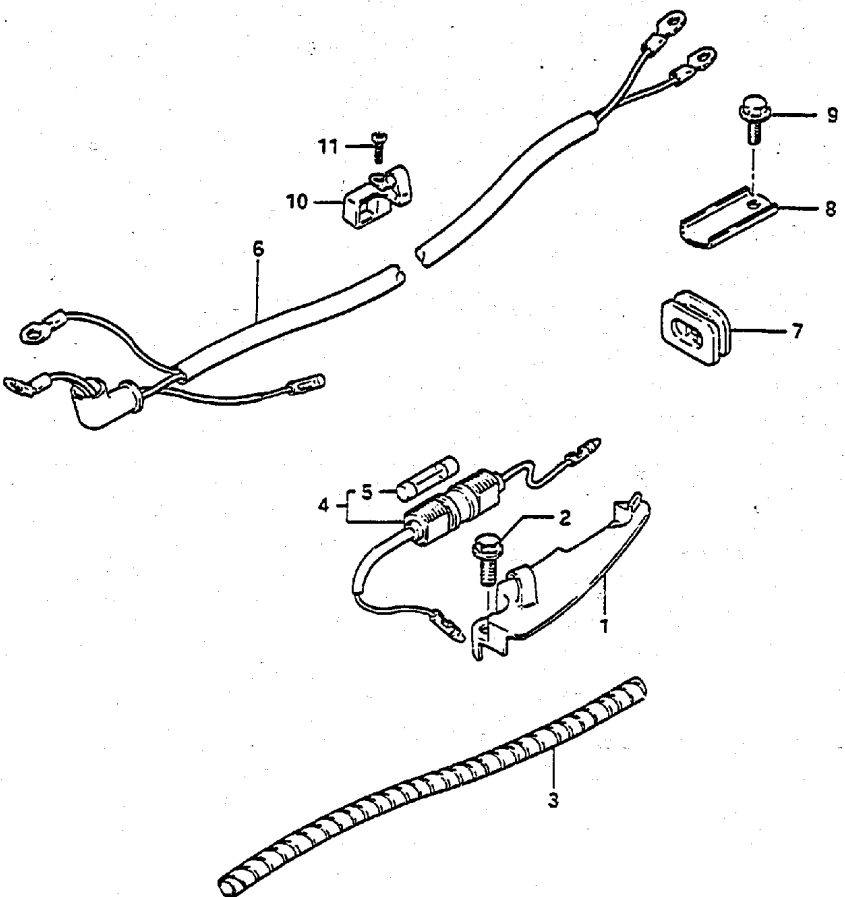

FIG. 13

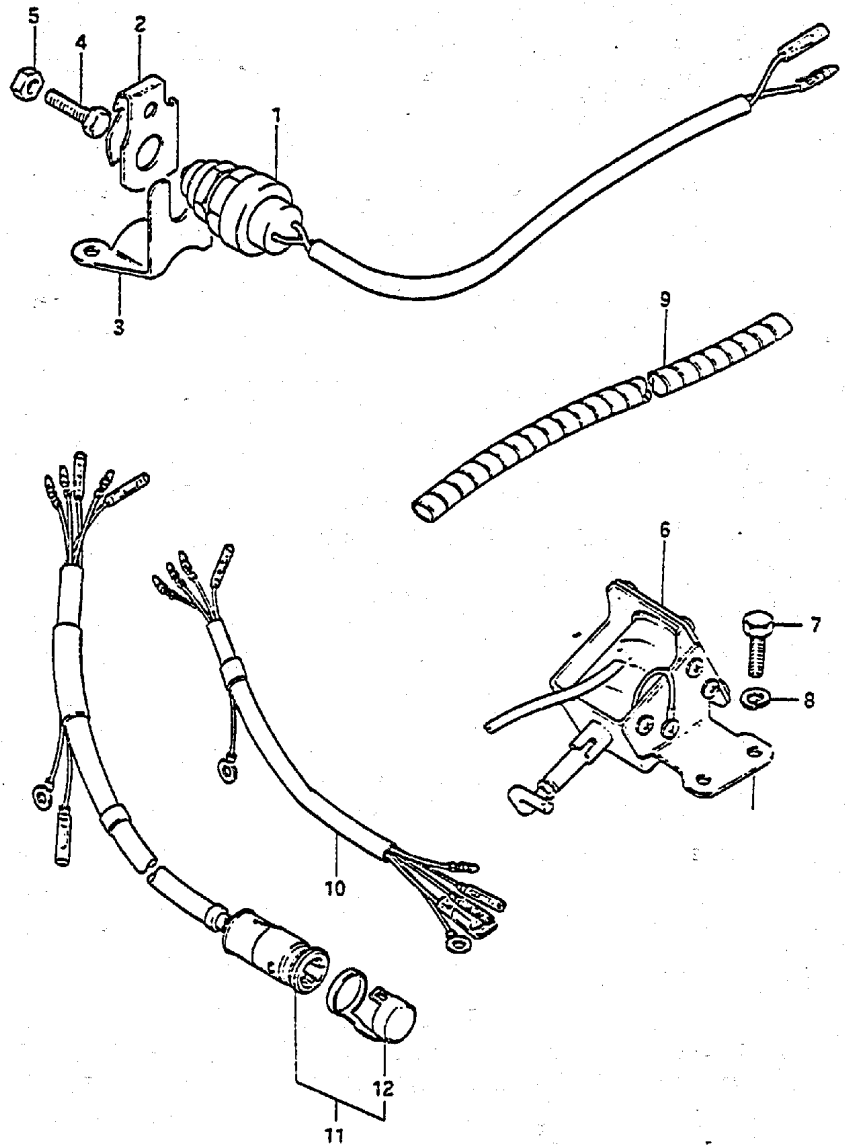
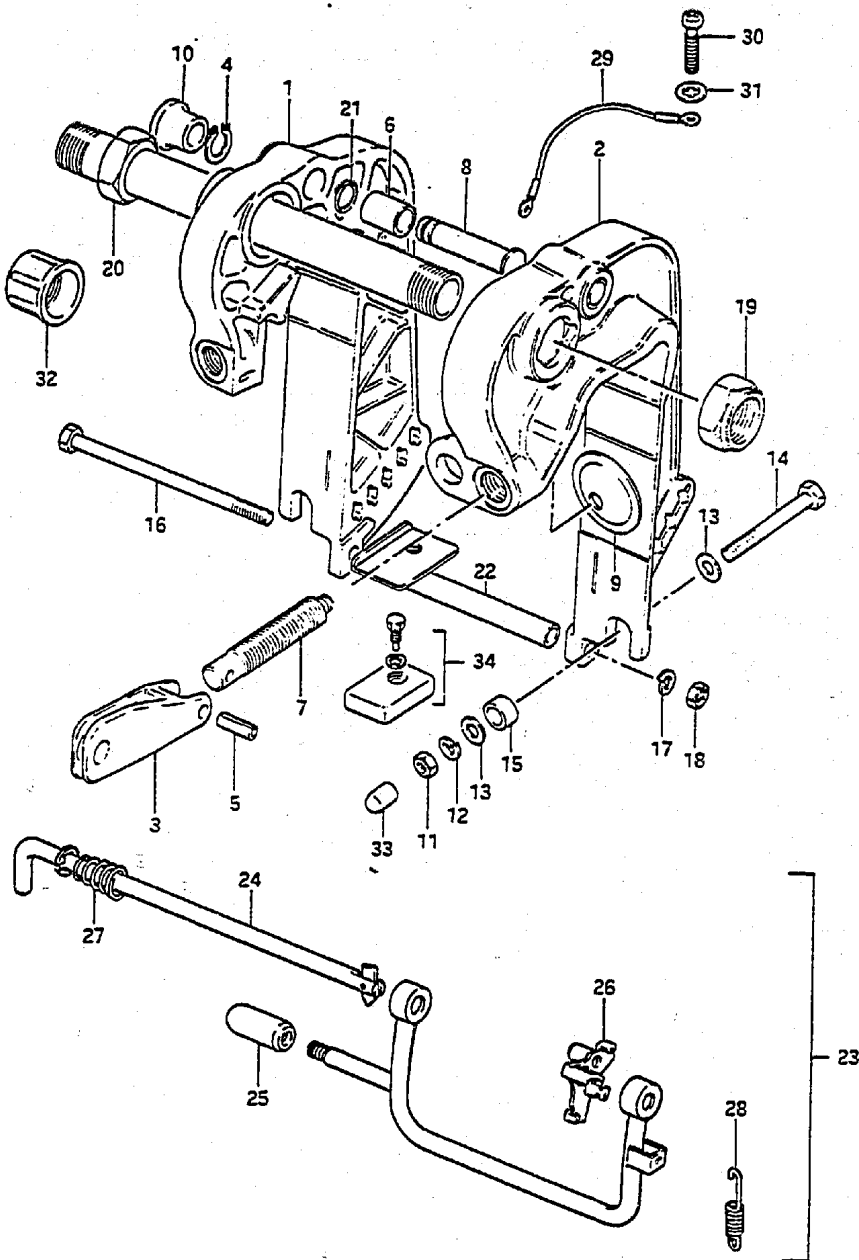

FIG. 15 (C- 8) ELECTRICAL

REF.NO.	PART NO.	DESCRIPTION	Q'TY	REMARKS
1	37721-96354	SWITCH, neutral	1	
2	37725-95300	ACTUATOR, neutral switch	1	
3	37726-96301	BRACKET, neutral switch	1	
4	09106-05015	BOLT	1	
5	09140-05005	NUT	1	
6	38600-96301	SOLENOID, choke	1	
7	09100-05004	BOLT (5x12)	2	
8	09162-05002	LOCK WASHER	2	
9	34863-94500	TUBE, wiring harness (L:50)	1	
10	36630-96310	WIRING HARNESS, remo-con 1	1	
11	36630-96321	WIRING HARNESS, remo-con 2	1	
12	36631-94300	.CAP	1	

FIG.16



D-2 CLAMP BRACKET

Q'TY

REMARKS

REF.NO.	PART NO.	DESCRIPTION	Q'TY	REMARKS
1	41110-96305-02M	BRACKET, clamp STBD	1	
2	41120-96340-02M	BRACKET, clamp PORT	1	
3	41212-93000-02M	HANDLE, clamp	2	
4	09380-12002	SNAP RING	1	
5	09205-06012	SPRING PIN	2	
6	09303-14002	BUSH	1	
7-1	41211-93910	SCREW, clamp (L:78)	2	OPT
7-2	41211-93920	SCREW, clamp (L:90)	2	
7-3	41211-93900	SCREW, clamp (L:68)	2	OPT
8	41222-96310	PIN, tilt stopper	1	
9	41213-98100	PLATE, clamp	2	
10	41221-96300	KNOB, tilt stopper	1	
11	09140-08016	NUT	2	
12	09162-08007	LOCK WASHER	2	
13	09160-08081	WASHER (8.5x23x1.5)	4	
14	09100-08239	BOLT (8x90)	2	
15	09180-09016	SPACER (9.2x13.8x9.5)	2	
16	09100-08196	BOLT (8x152)	1	
17	09162-08007	LOCK WASHER	1	
18	09140-08016	NUT	1	
19	09159-22004	NUT	1	
20	41130-96330	SHAFT, clamp bracket	1	
21	09380-12002	SPRING	1	
22	41310-96300	ROD, clamp bracket lower	1	
23	45700-96301	SHALLOW DRIVE ASSY	1	
24	45720-96301	.SHAFT	1	
25	45725-94400	.KNOB	1	
26	45730-96301	.PLATE	1	
27	09441-17001	.SPRING	1	
28	09443-08045	.SPRING	1	
29	36894-95200	LEAD	1	
30	09125-05050	SCREW	2	
31	09161-05014	WASHER	2	
32	41151-94500	CAP, bracket shaft	2	
33	41153-96300	CAP, transom bore	2	
34	55320-95310	ZINC SET, protection	1	

FIG. 17

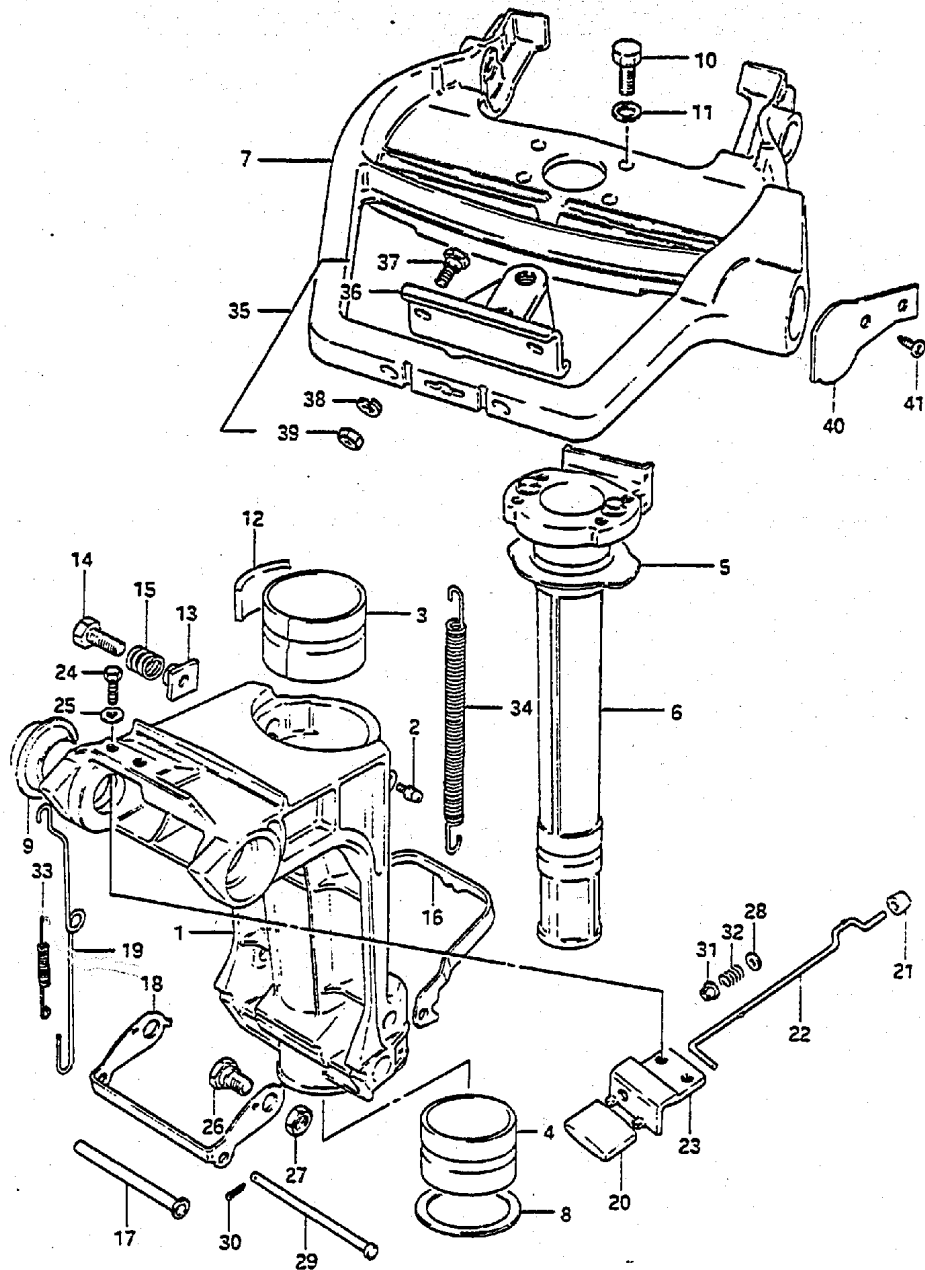

DT30R VH E3

FIG. 17 (D- 3) SWIVEL BRACKET

Q'TY

REF.NO.	PART NO.	DESCRIPTION	Q'TY	REMARKS
1	43111-96311-02M	BRACKET, swivel	1	
2	22511-99001	NIPPLE, clutch body	4	
3	43711-96301	BUSH, steering upper	1	
4	43712-96301	BUSH, steering under	1	
5	43721-96301	PLATE, upper bush	1	
6	43741-96302-02M	SHAFT, pilot	1	
7	43751-96321-02M	BRACKET, steering	1	
8	09160-40005	WASHER (40x58x2)	1	
9	09306-22004	BUSH	2	
10	09100-08219	BOLT	4	
11	09162-08003	LOCK WASHER	4	
12	43411-96300	ADJUSTER, steering	1	
13	43421-96301	BUSH	1	
14	09119-08044	BOLT	1	
15	09440-13045	SPRING	1	
16	45231-96303	ARM, reverse lock	1	
17	45246-96301	SPACER	1	
18	45241-96303	LINK, reverse lock arm	1	
19	45252-96302	LINK, release lever	1	
20	45255-96300	KNOB, release lever	1	
21	45257-96300	BUSH, release lever	1	
22	45260-96300	LEVER, release	1	
23	45311-96302-02M	BRACKET, release lever	1	
24	09100-05011	BOLT (5x12)	2	
25	09160-05010	WASHER	2	
26	09111-10034	BOLT	2	
27	09140-10032	NUT	2	
28	09160-04012	WASHER (4.2x10x1)	1	
29	09200-05011	PIN	1	
30	09204-01001	COTTER PIN	1	
31	09319-04001	BUSH	1	
32	09440-04021	SPRING	1	
33	09443-05013	SPRING	1	
34	09443-09036	SPRING	1	

DT30R VH E3

D3

FIG.17

FIG.17 (D- 4) SWIVEL BRACKET

Q'TY

REF.NO.	PART NO.	DESCRIPTION	Q'TY	REMARKS
35	67100-96300	ATTACHMENT SET	1	OPT Included with STD drag link
36	43755-96301	.ATTACHMENT, steering bracket	1	OPT
37	09100-08224	.BOLT (8x35)	2	OPT
38	09162-08007	.LOCK WASHER	2	OPT
39	09140-08016	.NUT	2	OPT
40	43754-94301-02M	COVER, steering	1	
41	09132-05024	SCREW	2	

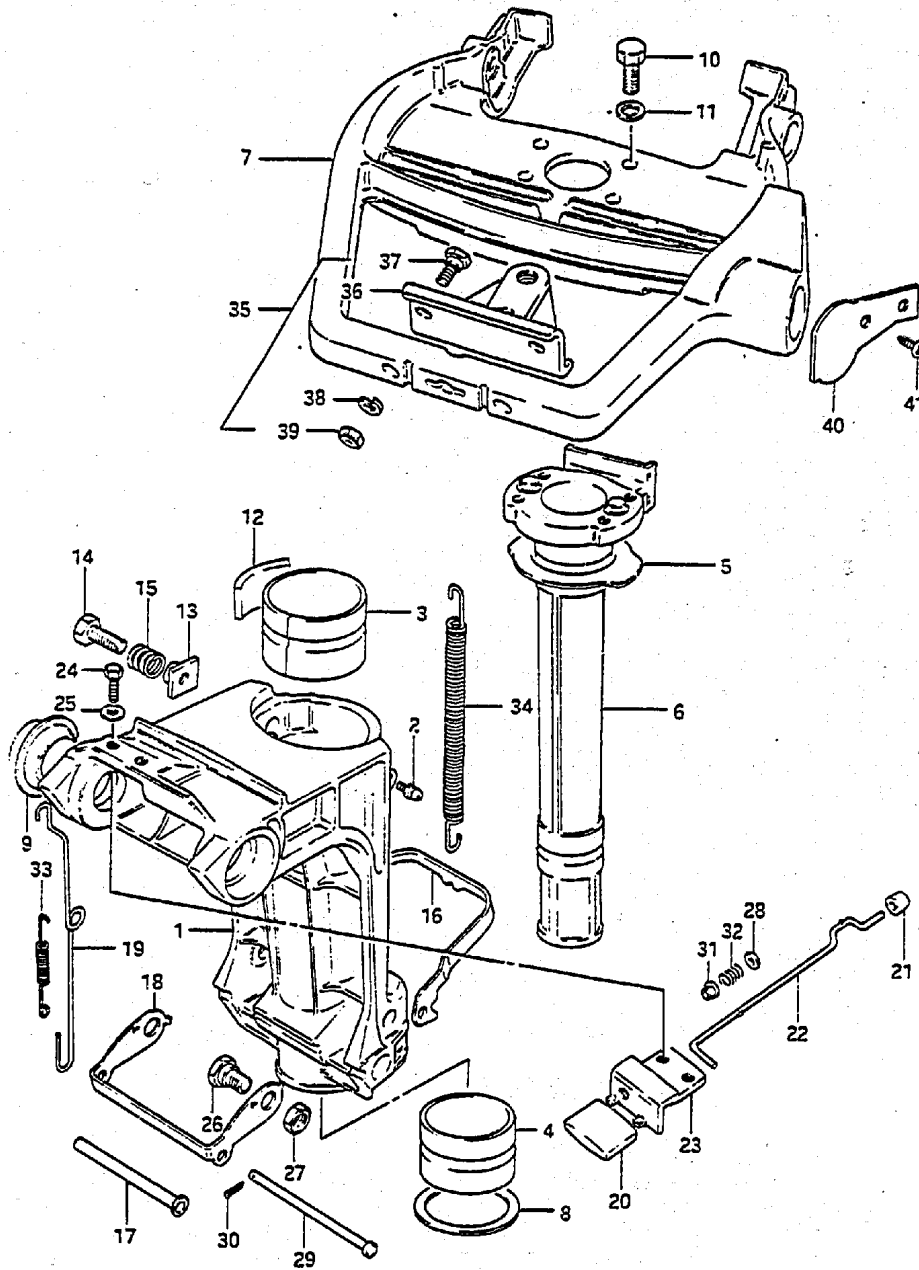

DT30R VH E3

DT30R VH E3

FIG. 18

FIG. 18 (D- 5) EXHAUST TUBE

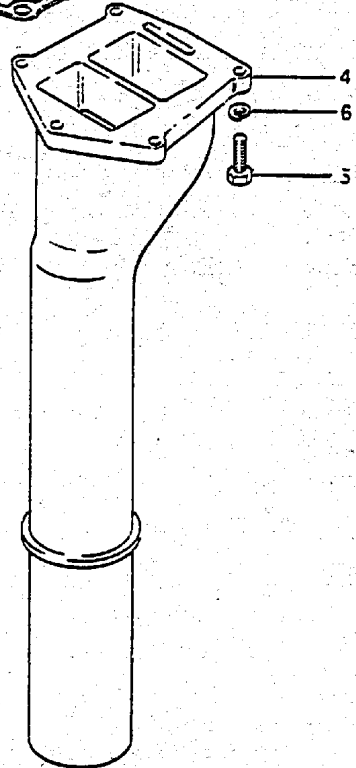
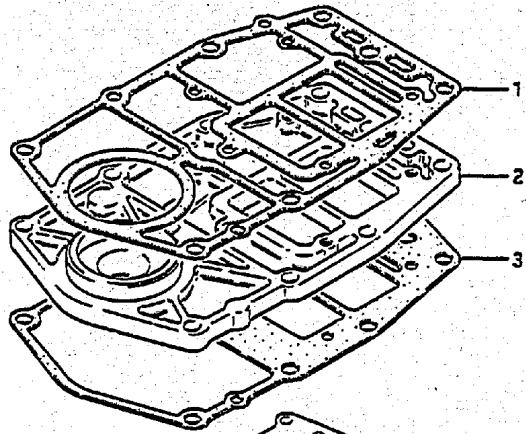

REF.NO.	PART NO.	DESCRIPTION	Q'TY	REMARKS
1	11433-96302	GASKET, lower oil seal housing	1	
2	11431-96310	HOUSING, under oil seal	1	
3	52113-96304	GASKET, drive shaft housing	1	
4-1	14211-96330	TUBE, exhaust (L)	1	
4-2	14211-96340	TUBE, exhaust (S)	1	
5	09100-06117	BOLT (6x35)	5	
6	09162-06001	LOCK WASHER	5	

← END

FIG.19

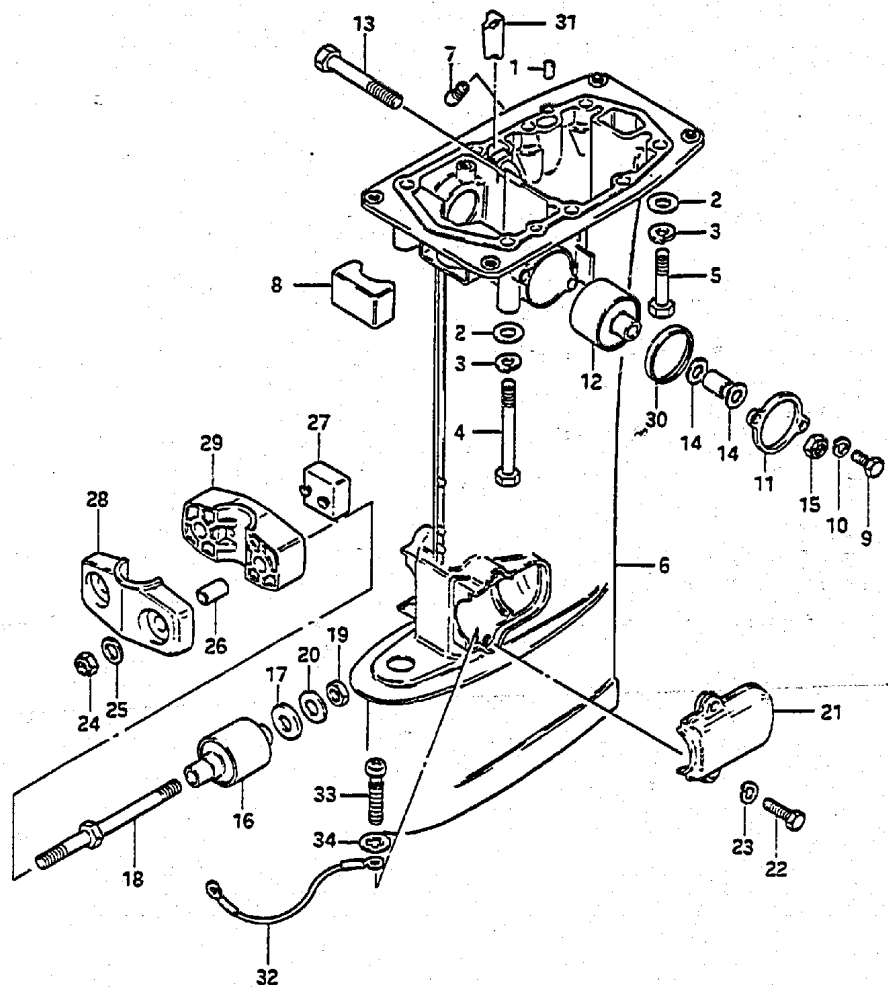

REF.NO.	PART NO.	DESCRIPTION	Q'TY	REMARKS
1	09202-06015	PIN	2	
2	09160-08015	WASHER	8	
3	09162-08003	LOCK WASHER	8	
4	09100-08203	BOLT (8x85)	4	
5	09100-08204	BOLT (8x50)	4	
6-1	52111-96321-02M	HOUSING, drive shaft (S)	1	-617392
6-2	52111-96322-02M	HOUSING, drive shaft (S)	1	617393-
6-3	52111-96330-02M	HOUSING, drive shaft (L)	1	-617392
6-4	52111-96331-02M	HOUSING, drive shaft (L)	1	617393-
7	52117-94400	TUBE, water inspection	1	617393-
8	54121-96300	MOUNTING, upper thrust reverse	1	
9	09100-06102	BOLT	4	
10	09162-06001	LOCK WASHER	4	
11	54137-96301-02M	COVER, upper mounting	2	
12	54130-96310	MOUNTING, upper	2	
13	09100-10260	BOLT (10x75)	2	
14	09160-10082	WASHER (10.5x19x2)	4	
15	09159-10050	NUT	2	
16	54160-96310	MOUNTING, lower	2	
17	54165-96310	DAMPER, reverse stopper	2	
18	54166-96301	BOLT, lower mounting	2	
19	09140-10032	NUT	2	
20	09160-10083	WASHER (10.5x30x3.2)	2	
21	54221-96301-02M	COVER, lower mounting	2	
22	09100-06104	BOLT	4	
23	09162-06001	LOCK WASHER	4	
24	09159-10050	NUT	2	
25	09160-10082	WASHER (10.5x19x2)	2	
26	09180-10102	SPACER	2	
27	54151-96300	MOUNTING, lower thrust	1	
28	54211-96310-02M	BRACKET, lower mount foward	1	
29	54212-96302-02M	BRACKET, lower mount aft	1	
30	54138-96300	SLEEVE, upper mounting	2	
31	17568-96300	PLUG	1	
32	36894-95200	LEAD	1	
33	09125-05050	SCREW	2	
34	09161-05014	WASHER	2	

FIG. 20

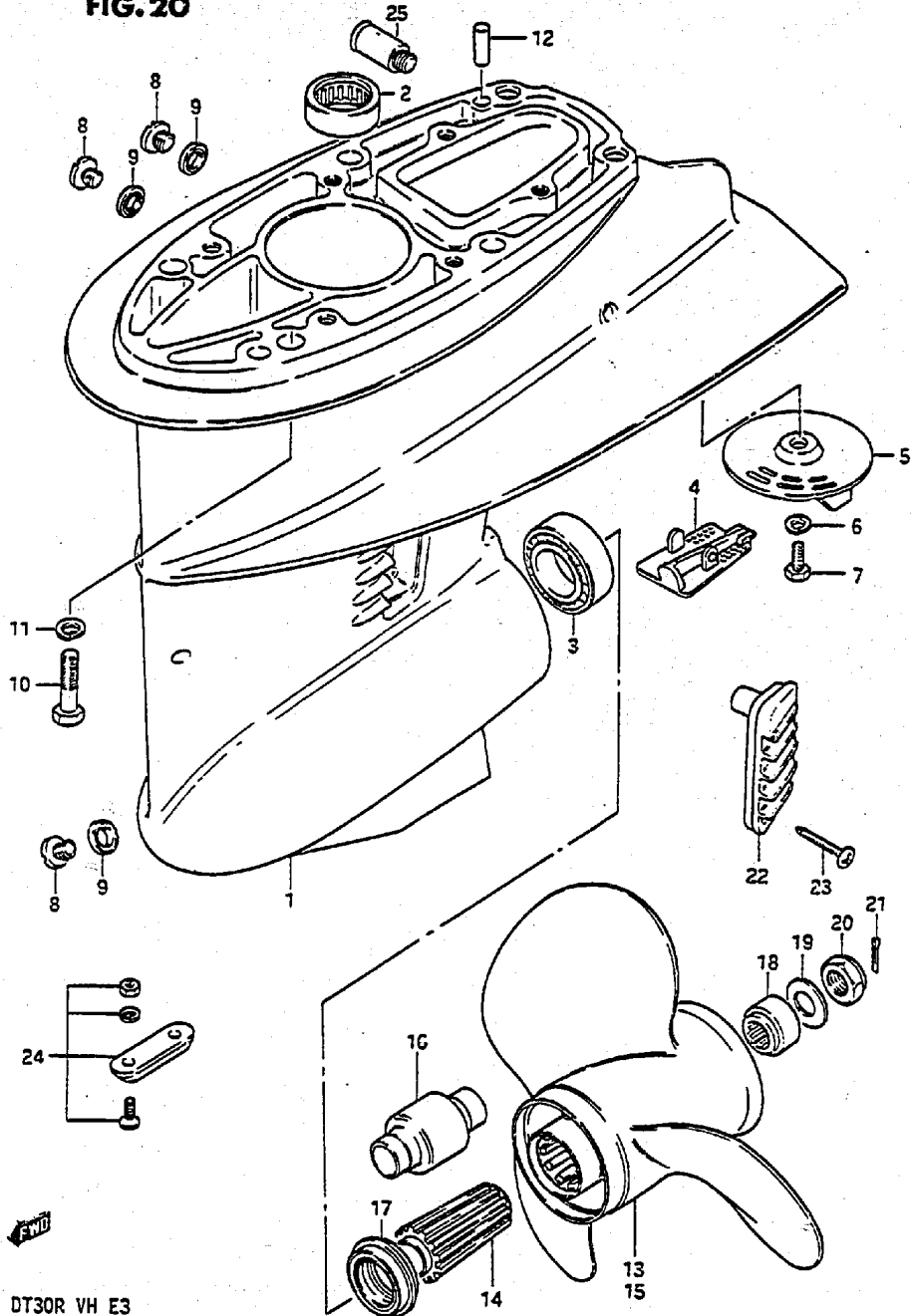

REF.NO.	PART NO.	DESCRIPTION	Q'TY	REMARKS
1	55100-96301-02M	CASE ASSY, gear	1	
2	09263-20046	.BEARING (20.63x26.98x25.4)	1	
3	09265-25015	.BEARING	1	
4	55114-96301	.COVER, gear case	1	
5	55125-96302	TRIM TAB	1	
6	09162-08003	LOCK WASHER	1	
7	09100-08215	BOLT (8x20)	1	
8	09248-10005	PLUG	3	
9	09168-10022	GASKET (10x17x1.5)	3	
10	09100-08224	BOLT (8x35)	6	
11	09162-08003	LOCK WASHER	6	
12	09202-06015	PIN	2	
13-1	58110-96301-01T	PROPELLER (3x10-1/4x9)	1	P900
13-2	58110-96312-01T	PROPELLER (3x10-1/4x10)	1	P1000
13-3	58110-96321-01T	PROPELLER (3x10-1/4x11)	1	P1100
13-4	58110-96331-01T	PROPELLER (3x10-1/4x12)	1	P1200,(L TYPE:STD)
13-5	58110-96341-01T	PROPELLER (3x10-1/4x13)	1	P1300,(S TYPE:STD)
13-6	58110-96351-01T	PROPELLER (3x10-1/4x14)	1	P1400
13-7	58110-96361-01T	PROPELLER (3x10-1/4x15)	1	P1500
14	58120-96313	BUSH	1	not included with prop
15-1	58100-96400-01T	PROPELLER (3x10-1/4x9)	1	P901
15-2	58100-96410-01T	PROPELLER (3x10-1/4x10)	1	P1001
15-3	58100-96420-01T	PROPELLER (3x10-1/4x11)	1	P1101
15-4	58100-96430-01T	PROPELLER (3x10-1/4x12)	1	P1201
15-5	58100-96440-01T	PROPELLER (3x10-1/4x13)	1	P1301
15-6	58200-96400	*PROPELLER (3x10-1/4x13)	1	PS1300, stainless steel
15-7	58100-96450-01T	PROPELLER (3x10-1/4x14)	1	P1401
15-8	58100-96460-01T	PROPELLER (3x10-1/4x15)	1	P1501
16	58120-96400	.BUSH	1	included with prop
17-1	57632-96312	STOPPER, propeller bush	1	for Ref.No.13
17-2	57632-96400	STOPPER, propeller bush	1	for Ref.No.15

*Must also use p/n 57632-96400, ref. 17-2

FIG. 20

FIG. 20 (D- 8) GEAR CASE

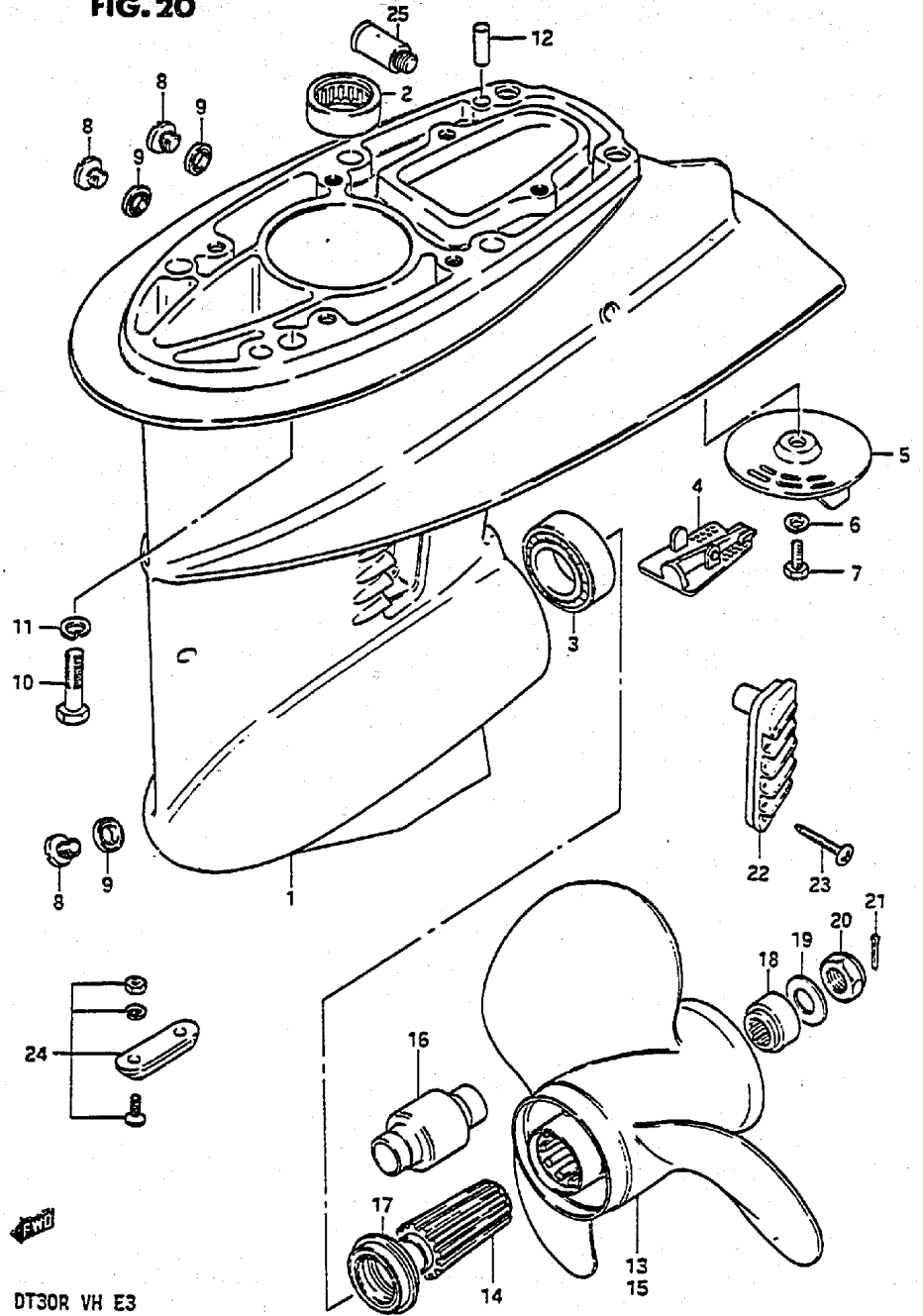

REF.NO.	PART NO.	DESCRIPTION	Q'TY	REMARKS
18	57633-96300	SPACER	1	
19	09160-14028	WASHER (14.5x30x2.5)	1	
20	09159-14011	NUT	1	
21	09204-03004	COTTER PIN	1	
22	17631-96310	FILTER, water	2	
23	03142-04259	TAPPING SCREW	2	
24	55300-95500	ZINC, propeller	1	OPT
25	55181-95200	ATTACHMENT, flush hose	1	

DT30R VH E3

DT30R VH E3

D8

FIG. 21

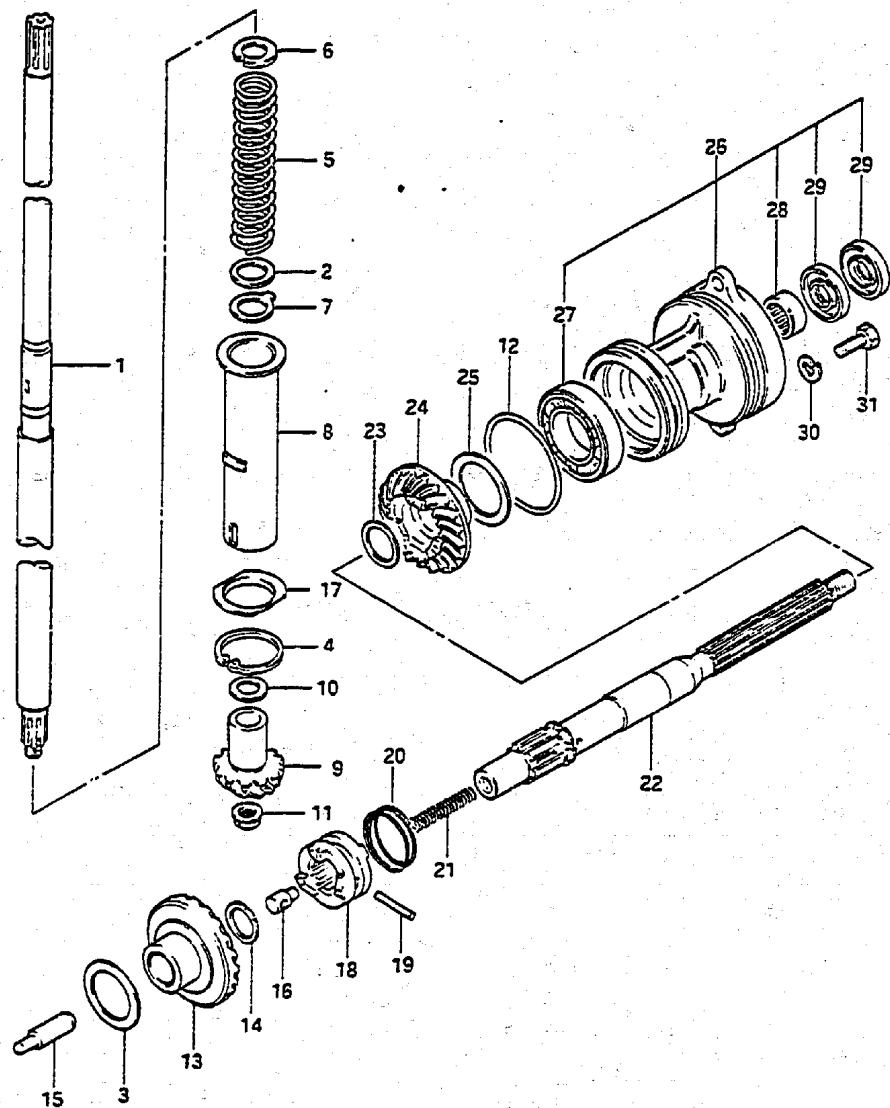

FIG. 21 (D-10) TRANSMISSION

REF.NO.	PART NO.	DESCRIPTION	Q'TY	REMARKS
18	57621-96300	SHIFTER, clutch dog	1	
19	09202-05021	PIN	1	
20	09440-35004	SPRING	1	
21	09440-07041	SPRING	1	
22	57610-96303	SHAFT, propeller	1	
23-1	08221-20256	WASHER (T:0.8)	0-1	
23-2	09160-20035	WASHER (T:0.9)	0-1	
23-3	08211-20251	WASHER (T:1.0)	0-1	
23-4	09160-20036	WASHER (T:1.1)	0-1	
23-5	09160-20037	WASHER (T:1.2)	0-1	
23-6	09160-20038	WASHER (T:1.3)	0-1	
24	57521-96311	GEAR, reverse	1	
25-1	08211-30401	THRUST WASHER (T:1)	0-1	
25-2	08221-30404	THRUST WASHER (T:0.2)	0-2	
25-3	08221-30405	THRUST WASHER (T:0.5)	0-1	
25-4	08221-30406	THRUST WASHER (T:0.8)	0-1	
26	56120-96311-02M	HOUSING, propeller shaft brg	1	
27	08113-60060	.BEARING	1	
28	09263-20047	.BEARING (20x26x20)	1	
29	09289-20009	.OIL SEAL (20x34x6.5)	2	
30	09162-06001	LOCK WASHER	2	
31	09100-06136	BOLT	2	

FIG. 22

FIG. 22 (E- 2) UNDER COVER

Q'TY

REMARKS

REF.NO.	PART NO.	DESCRIPTION	Q'TY	REMARKS
1	61110-96304-02M	COVER, engine under	1	
2	61113-96300	SEAL, under cover	1	
3	09320-10031	CUSHION	4	
4	09180-06112	SPACER (6.8x10x11.5)	4	
5	09103-06094	BOLT	4	model VG
6	09100-06120	BOLT	4	model VH
7	09160-06099	WASHER	4	model VH
8	09250-08007	CAP, cushion	2	
9	61631-96301	HOOK, under cover	1	
10	09164-13005	WASHER	1	
11	09306-13002	BUSH	1	
12	61633-96002-02M	LEVER, hook	1	
13	01107-06102	BOLT	1	
14	08322-21062	WASHER	1	
15	13625-94300	CAP, choke rod guide	1	
16	22511-99001	NIPPLE, clutch notch	1	
17	36612-94301	GROMMET, No.1	1	
18	36613-94300	GROMMET, No.2	1	
19	36632-95501	CLAMP	1	
20	61138-96301	COVER, water	1	
21	02142-06122	BOLT	2	
22	63625-94300	CAP	1	

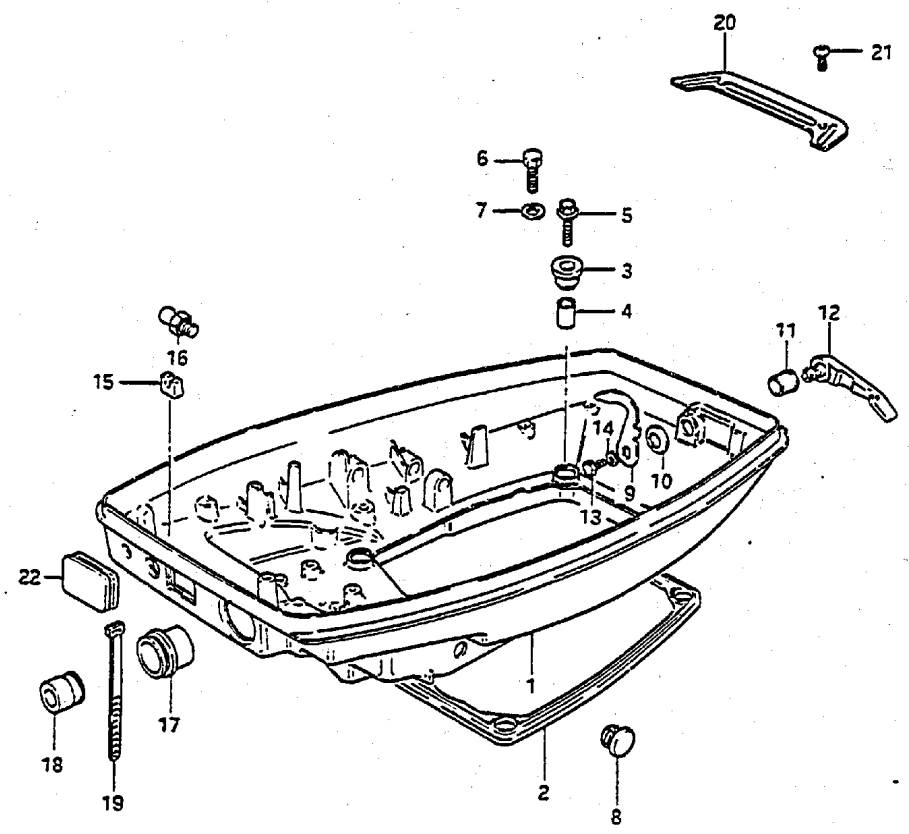
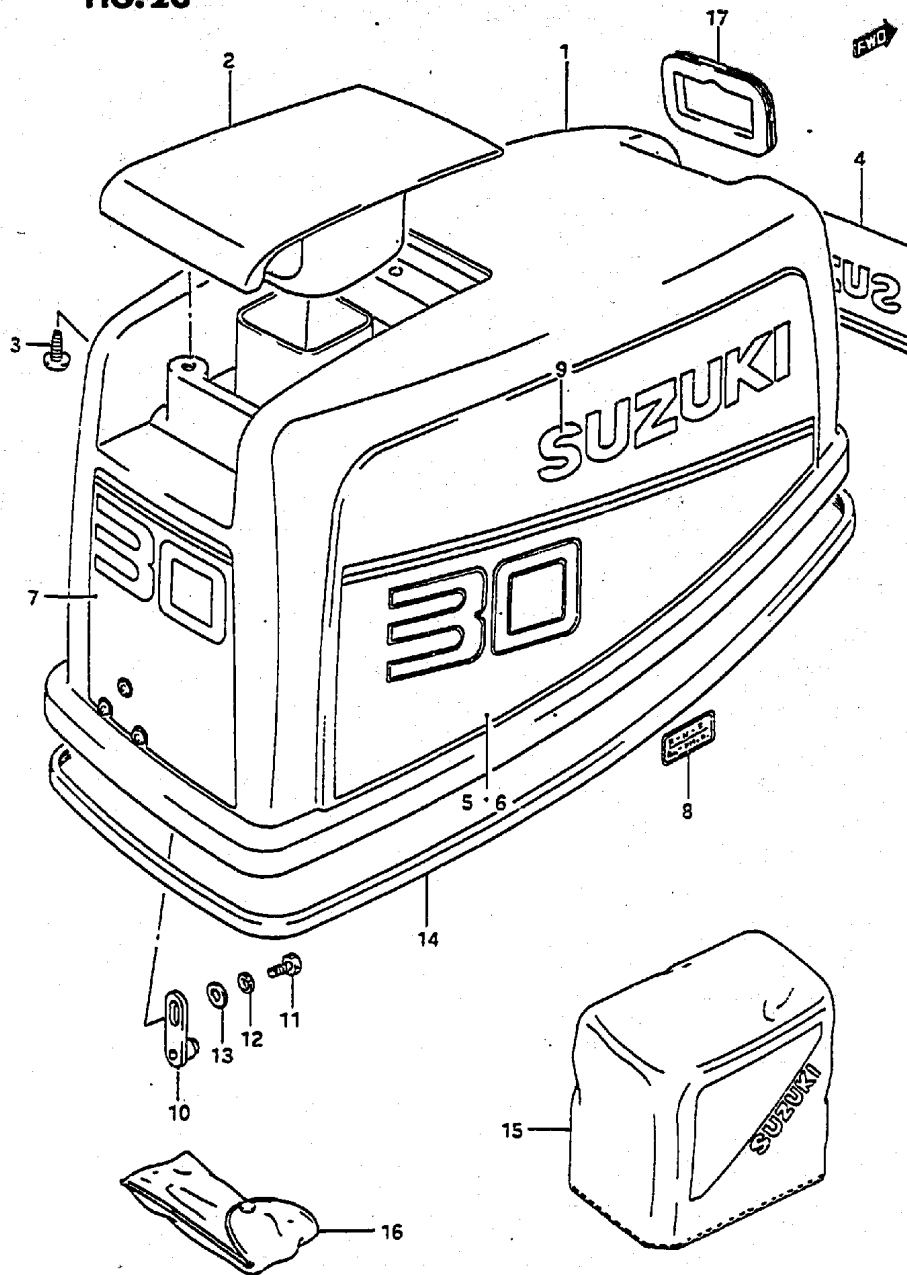

FIG. 23

FIG. 23 (E- 3) ENGINE COVER

Q'TY



REF.NO.	PART NO.	DESCRIPTION	Q'TY	REMARKS
1	61401-96840-02M	COVER SET, engine	1	
2	61431-96301-02M	.HANDLE, tilt up	1	
3	03242-06169	.SCREW	3	
4	61422-93930-70G	.MARK, emblem, front (Gold,Black)	1	
5	61443-96390-26G	.DECAL, side STBD (Black)	1	
6	61453-96390-26G	.DECAL, side PORT (Black)	1	
7	61435-96390-70G	.EMBLEM, rear (Gold,Black)	1	
8	21131-96003	.MARK, clutch shift	1	
9	61441-96310-019	.EMBLEM, side (Black)	2	
10	61610-96302	.FASTENER	1	
11	01107-06122	.BOLT	1	
12	08321-21062	.LOCK WASHER	1	
13	08322-21062	.WASHER	1	
14	61112-96302	RUBBER, under cover	1	
15	68110-95210	COVER, weather	1	OPT
16	09800-81800	TOOL SET	1	
17	61622-96301	SEAL, rubber	1	

FIG. 25

FIG. 25 (E- 5) REMOTE CONTROL PARTS

Q'TY

REMARKS

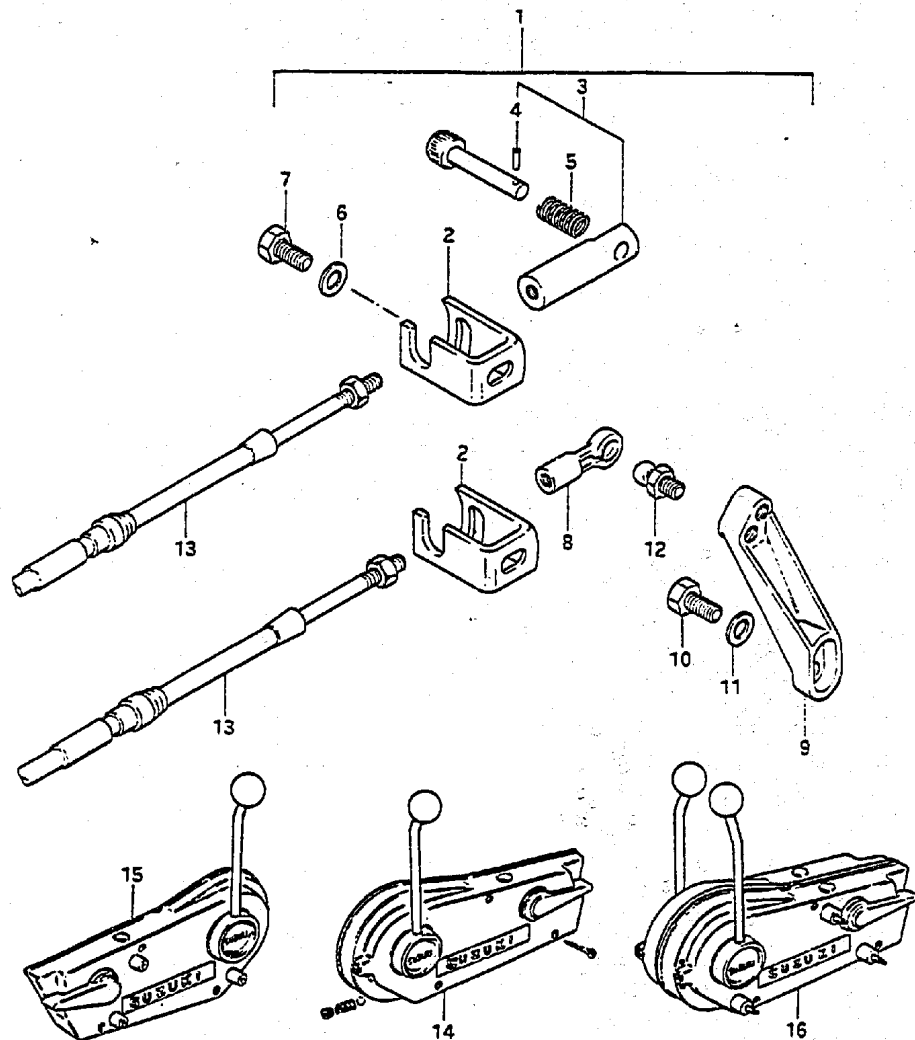

REF.NO.	PART NO.	DESCRIPTION	Q'TY	REMARKS
1	67130-94302-02M	REMOTE CONTROL PARTS ASSY	1	
2	67341-94301	.HOLDER, remo-con cable	2	
3	67440-93701	.GUIDE, clutch cable	1	
4	09205-02006	..SPRING PIN	1	
5	09440-09012	..SPRING	1	
6	09160-06015	.WASHER (6.5x13x1)	2	
7	09100-06115	.BOLT (6x15)	2	
8	67466-95200	.CONNECTOR, remo-con cable	1	
9	67414-94301-02M	.LEVER, remo-con throttle	1	
10	09100-06115	.BOLT (6x15)	1	
11	09160-06015	.WASHER (6.5x13x1)	1	
12	09119-06047	.BALL PIVOT	1	
13-1	67320-95500	CABLE ASSY, remocon 6F (1.8M)	2	OPT
13-2	67320-95510	CABLE ASSY, remocon 7F (2.1M)	2	OPT
13-3	67320-95520	CABLE ASSY, remocon 8F (2.4M)	2	OPT
13-4	67320-95530	CABLE ASSY, remocon 9F (2.7M)	2	OPT
13-5	67320-95540	CABLE ASSY, remocon 10F (3.1M)	2	OPT
13-6	67320-95550	CABLE ASSY, remocon 11F (3.4M)	2	OPT
13-7	67320-95560	CABLE ASSY, remocon 12F (3.7M)	2	OPT
13-8	67320-95570	CABLE ASSY, remocon 13F (4.0M)	2	OPT
13-9	67320-95580	CABLE ASSY, remocon 14F (4.3M)	2	OPT
13-10	67320-95590	CABLE ASSY, remocon 15F (4.6M)	2	OPT
13-11	67320-95600	CABLE ASSY, remocon 16F (4.9M)	2	OPT
13-12	67320-95610	CABLE ASSY, remocon 17F (5.2M)	2	OPT
13-13	67320-95620	CABLE ASSY, remocon 18F (5.5M)	2	OPT
13-14	67320-95630	CABLE ASSY, remocon 19F (5.8M)	2	OPT
13-15	67320-95640	CABLE ASSY, remocon 20F (6.1M)	2	OPT
13-16	67320-95650	CABLE ASSY, remocon 22F (6.7M)	2	OPT
14	67200-95203	BOX ASSY, remocon STBD	1	OPT
15	67200-95213	BOX ASSY, remocon PORT	1	OPT
16	67200-95871	BOX ASSY, twin remocon	1	OPT

FIG. 26

FIG. 26 (E- 6) REMOTE CONTROL

Q'TY

REMARKS

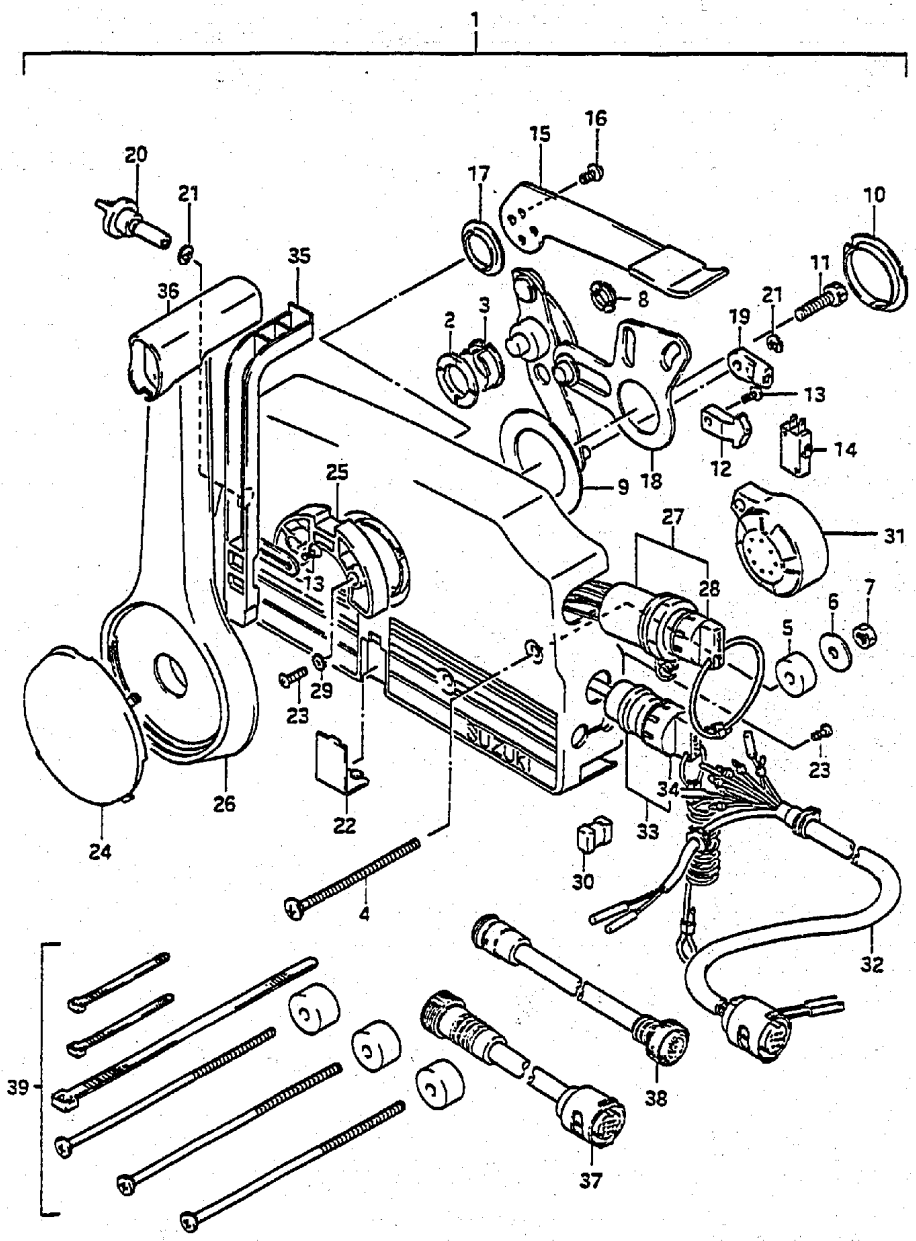

REF.NO.	PART NO.	DESCRIPTION	Q'TY	REMARKS
1	67200-95641	REMOTE CONTROL BOX	1	
2	67232-95600	.BUSH	1	
3	67232-95620	.BUSH	1	
4	67296-95600	.SCREW	3	
5	67294-95600	.SPACER	3	
6	67288-94310	.WASHER	3	
7	09140-06004	.NUT	3	
8	67232-95610	.BUSH	2	
9	67253-95600	.WASHER	1	
10	67252-95600	.BUSH	2	
11	09100-08232	.BOLT	1	
12	67214-95600	.ACTUATOR	1	
13	67296-94300	.SCREW	3	
14	37721-94600	.SWITCH, neutral	1	
15	67241-95650	.LEVER, free throt	1	
16	09126-05003	.SCREW	2	
17	67243-95600	.BUSH	1	
18	67220-95600	.PLATE ASSY	1	
19	67275-95600	.END, cable	2	
20	67223-95600	.KNOB, brake ADJ	1	
21	67292-94300	.E RING	3	
22	67267-95610	.COVER, wire	1	
23	67296-95610	.SCREW	7	
24	67257-95610	.CAP, lever	1	
25	67256-95600	.HOLDER, neutral lock	1	
26	67251-95650	.LEVER, handle	1	
27	37110-94601	.IGNITION SWITCH	1	
28-1	37141-94400	..KEY, spare (101)	1	
28-2	37141-94410	..KEY, spare (102)	1	
28-3	37141-94420	..KEY, spare (103)	1	
28-4	37141-94430	..KEY, spare (104)	1	
28-5	37141-94440	..KEY, spare (105)	1	
28-6	37141-94450	..KEY, spare (106)	1	

FIG. 26

FIG. 26 (E- 7) REMOTE CONTROL

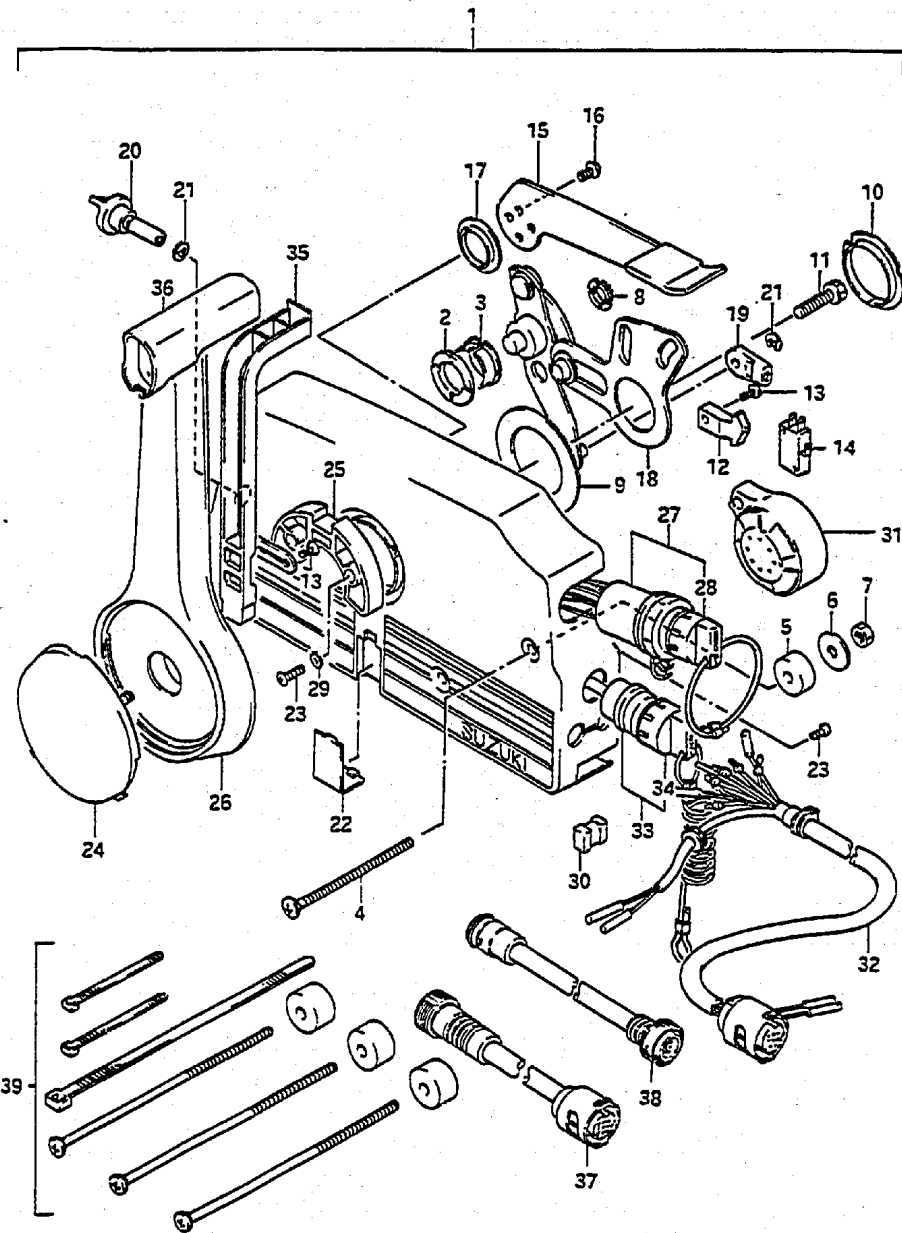

REF.NO.	PART NO.	DESCRIPTION	Q'TY	REMARKS
29	67297-95600	.WASHER	2	
30	67273-95600	.SPACER	1	
31	38500-87000	.BUZZER	1	
32	36620-94610	.WIRING HARNESS	1	
33	37820-94402	.SWITCH ASSY, emergency	1	
34	37823-94400	..CAP & ROPE	1	
35	67255-95600	.ARM NEUTRAL LOCK	1	
36	67261-95610	.GRIP	1	
37	36641-94701	ADAPTER (D.N)	1	OPT
38	36642-94703	ADAPTER (N.O)	1	OPT
39	67140-95600	ATTACHMENT, twin remo-con kit	1	OPT

FIG. 27

FIG. 27 (E- 8) DRAG LINK

REF. NO.	PART NO.	DESCRIPTION	Q'TY	REMARKS
1	67701-96300	DRAG LINK ASSY	1	
2	43755-96301	.ATTACHMENT, steering BRKT	1	
3	67721-94300	.SPACER	1	
4	67725-94500	.BOLT	1	
5	67726-94500	.NUT	2	
6	09100-08224	.BOLT	2	
7	09140-08016	.NUT	2	
8	67728-94500	.WASHER	3	
9	09162-08007	.LOCK WASHER	2	
10	41161-94400	SEAL, steering cable	1	

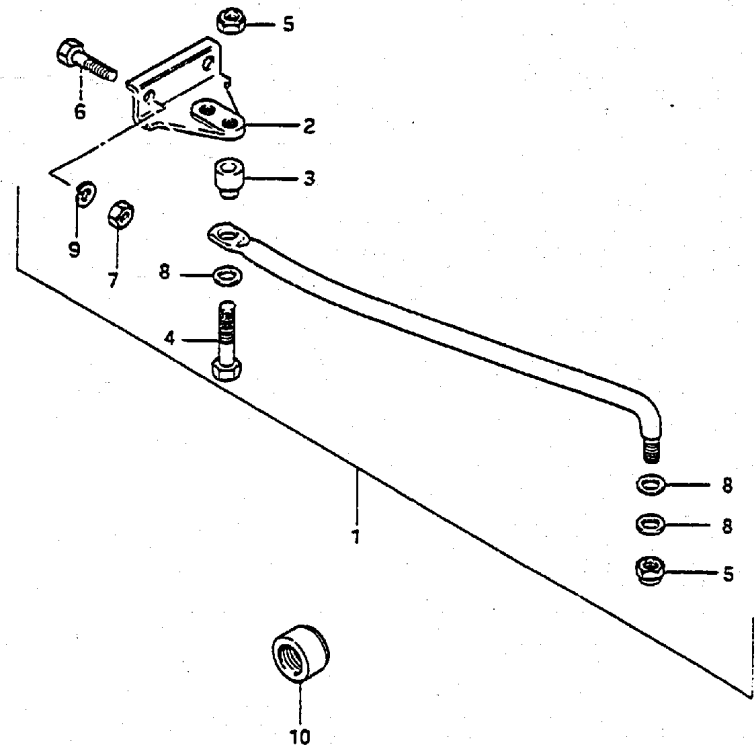

REF.NO.	PART NO.	DESCRIPTION	REMARKS
1	36620-95203	WIRING HARNESS, extension	1
2	36631-94300	.CAP	1
3	36630-96330	WIRING HARNESS, remo-con	1
4	36631-94300	.CAP, remo-con harness	1
5	37100-95210	PANEL ASSY, switch	1
6	37820-95353	.SWITCH ASSY, emergency	1
7	37823-95251	..CAP	1
8	37139-95251	.PANEL, switch	1
9	37150-93350	.HOLDER	1
10	37101-93310	.CAP, panel	2
11	37110-95210	.SWITCH, ignition	1
12-1	37141-93300	..KEY, spare (8511)	1
12-2	37141-93310	..KEY, spare (8512)	1
12-3	37141-93320	..KEY, spare (8513)	1
12-4	37141-93330	..KEY, spare (8611)	1
12-5	37141-93340	..KEY, spare (8612)	1
12-6	37141-93350	..KEY, spare (8613)	1
13	37820-94420	SWITCH ASSY, emergency	1
14	03112-04129	SCREW	4

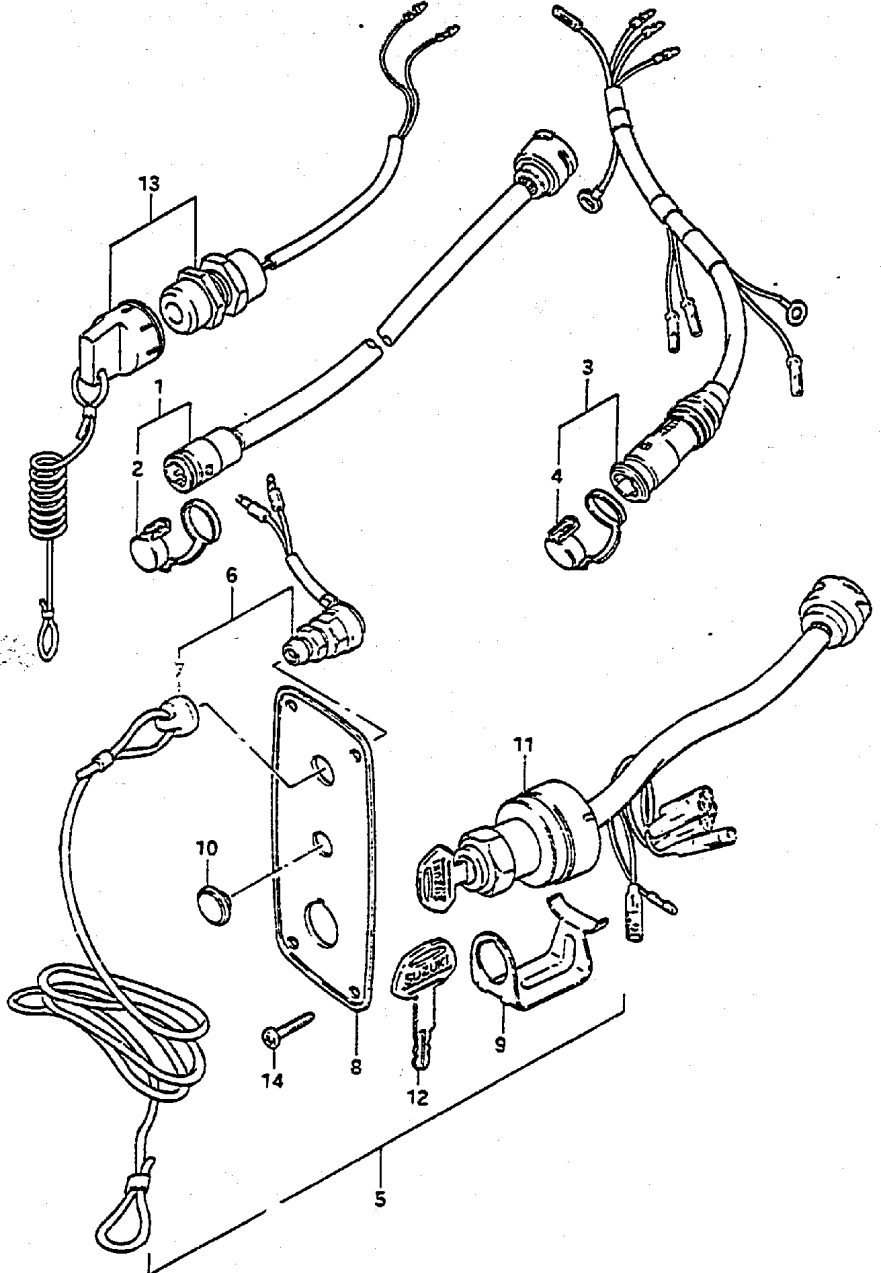
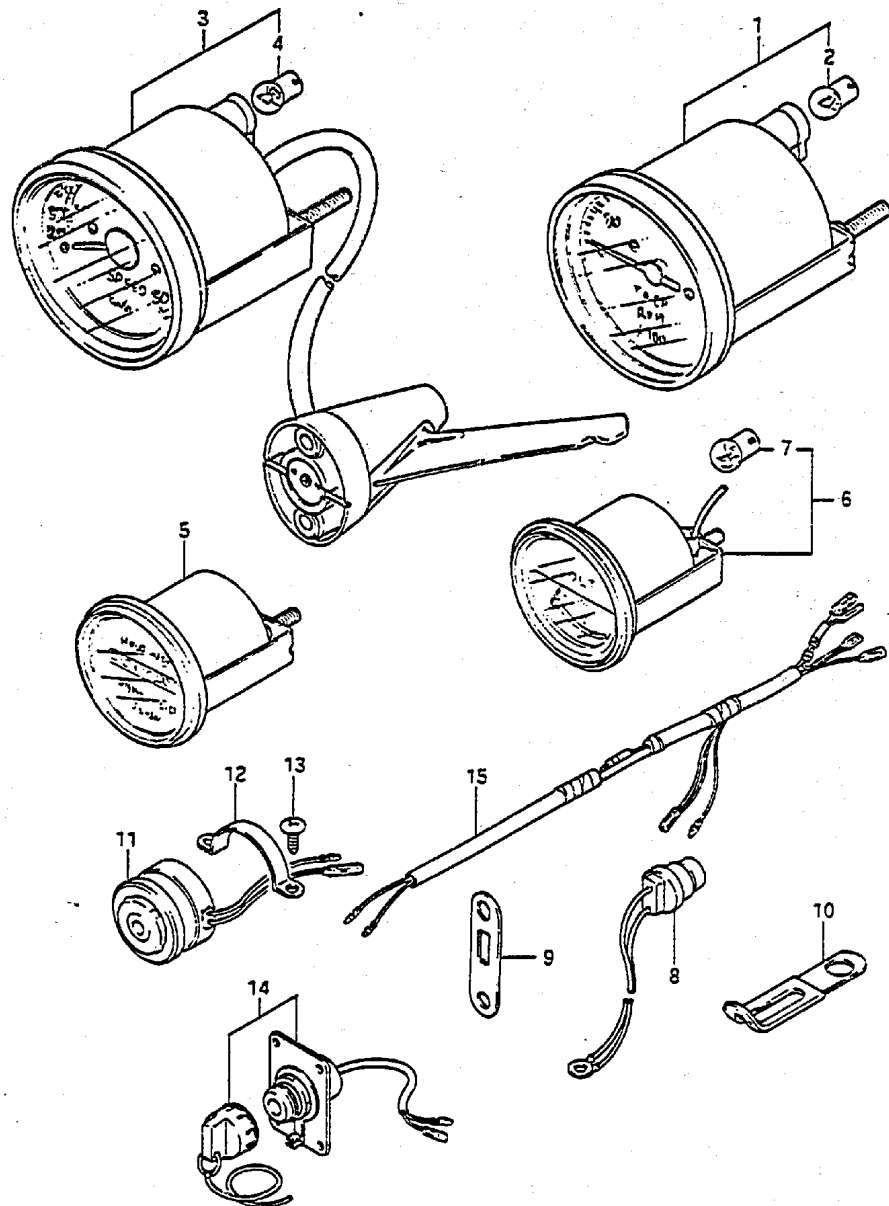

FIG. 29



REF.NO.	PART NO.	DESCRIPTION	Q'TY	REMARKS
1	*	TACHOMETER ASSY	1	
2	*	.BULB (12V,3.4W)	1	
3	*	SPEEDOMETER ASSY	1	KNOT
4	*	.BULB (12V,3.4W)	1	
5-1	*	METER ASSY, hour	1	
5-2	*	METER ASSY, hour	1	QUARTZ
6	*	METER ASSY, VOLTAGE	1	
7	*	.BULB (12V,3.4W)	1	
8	34850-94700	SWITCH, heat	1	
9	34853-94301	SUPPORTER, unit	1	
10	09404-08201	CLAMP (L:52)	1	
11	38500-95503	BUZZER, warning	1	
12	38501-95500	BAND, warning buzzer	1	
13	02112-05088	SCREW	2	
14	34108-94500	SWITCH ASSY, meter	1	
15	34109-94500	LEAD, meter extension	1	

* CONSULT LATEST EDITION OF ACCESSORY CATALOG
FOR CURRENT PART NUMBERS AND SPECIFICATIONS.

FIG.30

FIG.30 (F- 4) OPTIONAL : TYLLER HANDLE

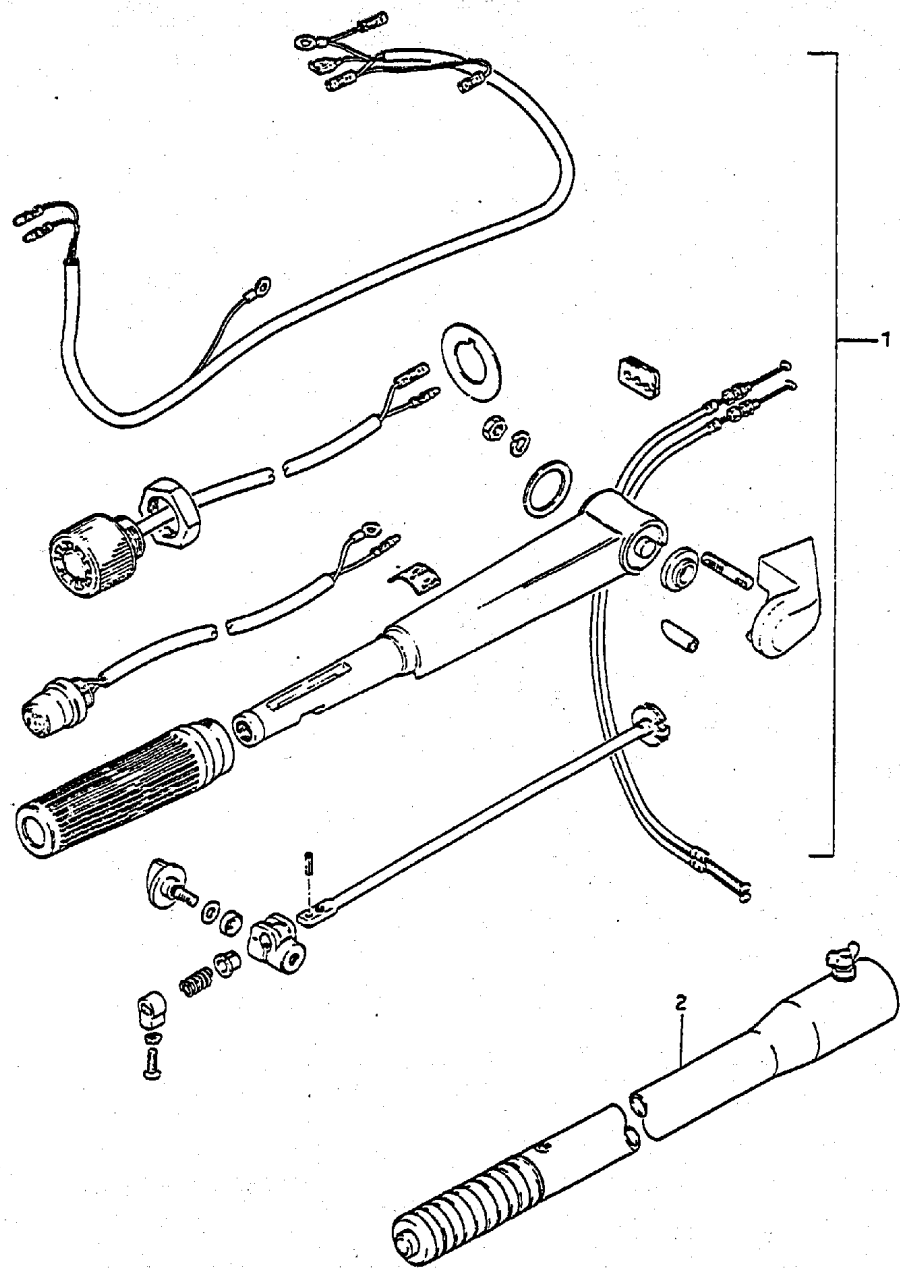

REF.NO.	PART NO.	DESCRIPTION	Q'TY	REMARKS
1	63001-96300-024	TYLLER HANDLE ASSY	1	
2	63300-93900	BAR ASSY, extension	1	

DT30R VH E3

DT30R VH E3

FIG.31

FIG.31 (F- 5) OPTIONAL

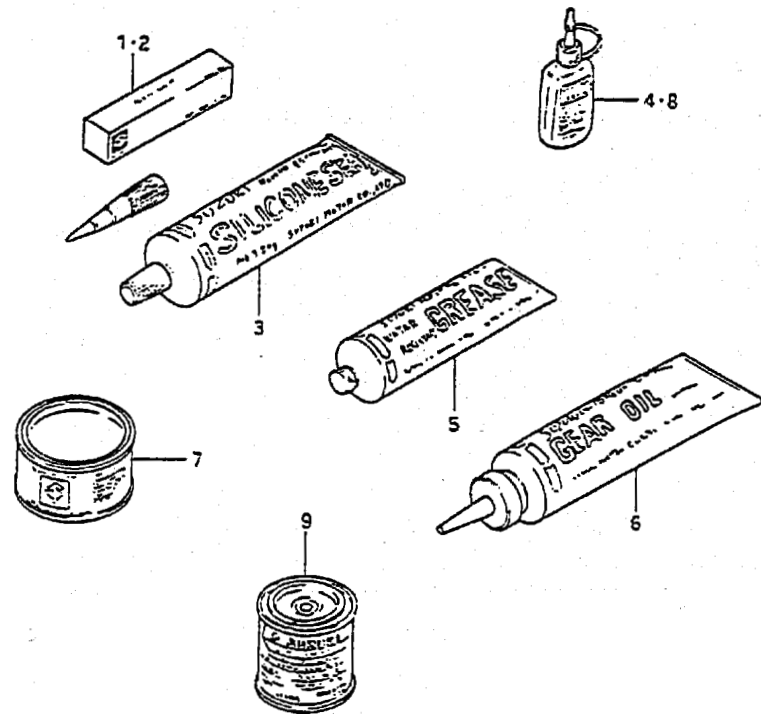

REF.NO.	PART NO.	DESCRIPTION	Q'TY	REMARKS
1	99000-31030	GASKET, liquid, No.4	1	100g
2	99000-31050	SUZUKI BOND, No.1	1	100g
3	99000-31120	SUZUKI SILICON SEAL	1	50g
4	99000-32050	THREAD LOCK CEMENT, super	1	50g
5-1	99000-25160	GREASE, water resistant	1	250g
5-2	99000-25170	GREASE, water resistant	1	50g
6	99000-22540	GEAR OIL, outboard motor	1	400cc
7	99000-25010	SUZUKI SUPER GREASE	1	450g
8	99000-32020	THREAD LOCK CEMENT, super	1	50g,103Q
9-1	99000-10109-01T	PAINT (Francois White)	1	90g
9-2	99000-10209-02M	PAINT (Arctic Silver)	1	90g