



# SUZUKI MARINE

Parts Book

DT 115 (1983-1985)



1703 Hwy 35 So., Laurence Harbor, NJ 08879

**(732) 264-7176**

**(800) 338-0645 FAX (732) 264-2472**

[www.brownspoint.com](http://www.brownspoint.com)

When it becomes necessary to replace parts on SUZUKI OUTBOARD MOTORS, always use SUZUKI GENUINE PARTS which have passed a strict inspection which guarantees quality and performance.

This parts catalogue covers the list of all service parts for SUZUKI DT115 TC QD, DT115TC VE and DT115TC VF.

INSTRUCTIONS FOR QUOTING THE CATALOGUE

1. DIMENSIONS

Dimensions of the parts in this catalogue are indicated in unit millimeters.

2. ABBREVIATIONS

Abbreviations used in this catalogue are as follows:

AR	: As required	NT	: Number of teeth
ASSY	: Assembly	OPT	: Optional
E.No.	: Engine number	OS	: Over size
F.No.	: Frame number	STD	: Standard
d	: Diameter of material	T	: Thickness
ID	: Inside diameter	US	: Under size
OD	: Outside diameter	W	: Width
L	: Length	S,L,UL,LL	: Transom type

~301234 : Up to F.No.11502-301234

301234~ : From F.No.11502-301234

$\frac{12}{|}$  x  $\frac{34}{|}$  x  $\frac{5.6}{|}$  ..... Figures in the description column show the dimensions of parts.

ID OD T(or W,L)

3. INNER PARTS OF ASSEMBLY

Parts number that have a period (.) mark in front of the part description on a text page are separately serviced parts of the assembly.

4. MODIFICATION NOTICE

A parts bulletin will be sent to you on all occasions when changes in parts occur, including interchangeable modifications between new parts and old ones.

5. NOTE

- 5-1. There are some different parts from those of production models among spare parts for the administrative reasons and common use of them with other models.
- 5-2. In respect of rubber hoses and vinyl tubes, please be sure to use them by cutting off according to the length mentioned on parts catalogue or what is actually required on the vehicle.
- 5-3. Note that the drawings on the illustration page are for ready reference of spare parts number, not to be used as an assembly manual. When assembling, use "SUZUKI SERVICE MANUAL".

6. ON ISSUE TO NEW SPARE PARTS CATALOGUE

This parts catalogue was arranged to include modifications as of Aug., 1984. Once each year new parts catalogue will be issued, containing, of course, all prior modifications. Upon receipt of each new issue the old catalogue should be destroyed.

7. ENGINE NUMBER

DT115TC QD : 11502-300001-304574

DT115TC VE : 11502-404575-406280

DT115TC VF : 11502-506281-

FIG.1

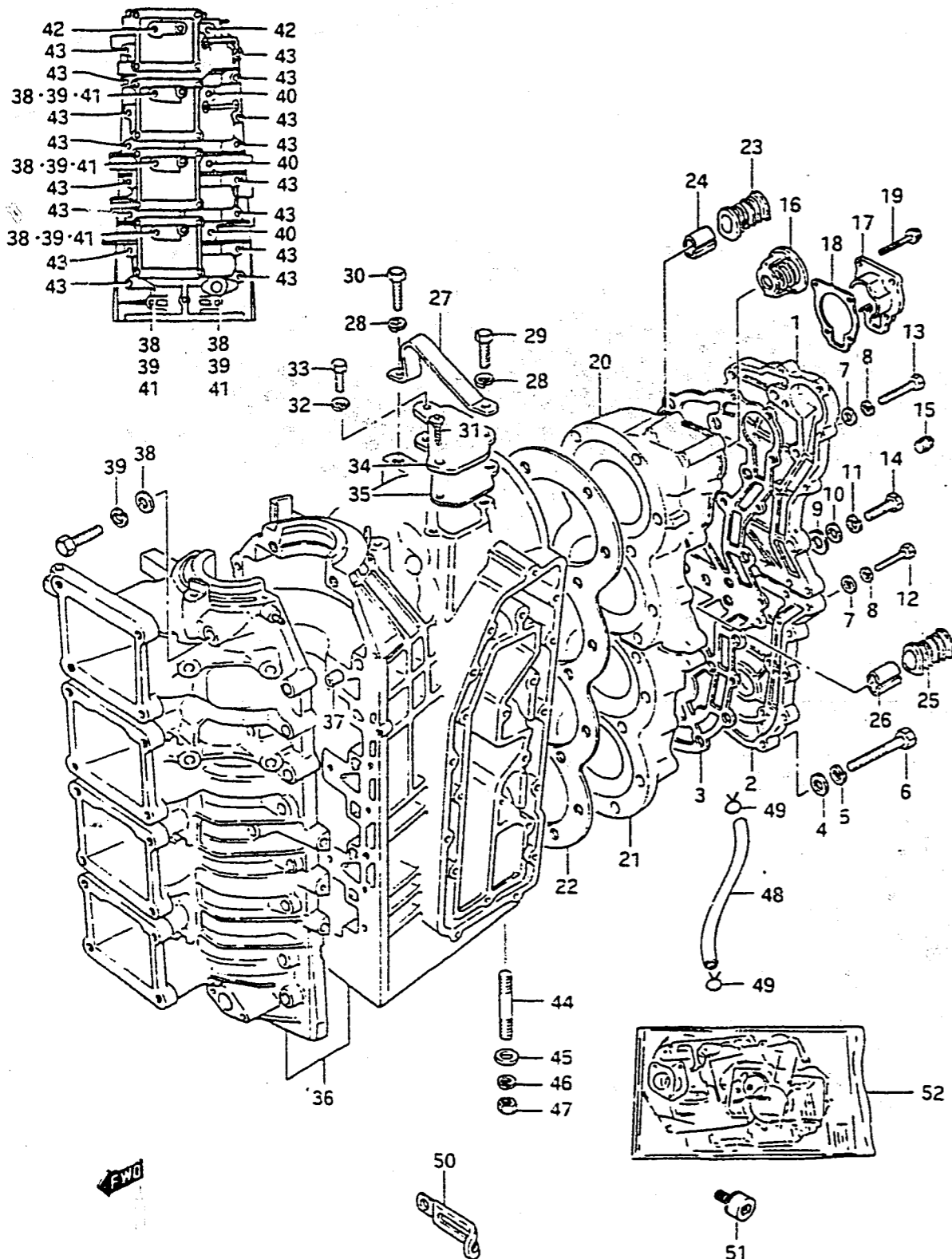


FIG.1 ( B- 2) CRANKCASE

Q'TY

REF.NO.	PART NO.	DESCRIPTION	Q'TY	REMARKS
1-1	11151-94502-02M	COVER, cylinder head upper	1	model QD/VE
1-2	11151-94610-02M	COVER, cylinder head upper	1	model VF
2-1	11161-94501-02M	COVER, cylinder head lower	1	model QD/VE
2-2	11161-94630-02M	COVER, cylinder head lower	1	model VF
3-1	11162-94503	GASKET, cover	1	model QD/VE
3-2	11162-94600	GASKET, cover	1	model VF
4	08322-11102	WASHER	20	
5	08321-21102	LOCK WASHER	20	
6	01107-10852	BOLT	20	
7-1	08322-21062	WASHER	8	model QD/VE
7-2	08322-21062	WASHER	5	model VF
8-1	08321-21062	LOCK WASHER	8	model QD/VE
8-2	08321-21062	LOCK WASHER	5	model VF
9	09160-08010	WASHER	2	
10	08322-11082	WASHER	2	model VF
11	08321-21082	LOCK WASHER	2	
12-1	01107-06302	BOLT	6	model QD/VE
12-2	01107-06302	BOLT	5	model VF
13	09100-06033	BOLT	2	model QD/VE
14	01107-08802	BOLT	2	
15	09246-04003	PLUG	1	model VF
16-1	17670-94503	THERMOSTAT (50°C)	1	~304327
16-2	17670-94510	THERMOSTAT (50°C)	1	304328~
17	17681-94600-02M	COVER, thermostat	1	model VF
18	17685-94600	GASKET	1	model VF
19	09103-06096	BOLT (6x40)	4	model VF
20-1	11111-94506-02M	CYLINDER HEAD, upper	1	model QD
20-2	11111-94517-02M	CYLINDER HEAD, upper	1	model VE
20-3	11111-94610-02M	CYLINDER HEAD, upper	1	model VF
21-1	11121-94502-02M	CYLINDER HEAD, lower	1	model QD
21-2	11121-94512-02M	CYLINDER HEAD, lower	1	model VE/VF
22-1	11141-94503	GASKET, cylinder head	1	~304394
22-2	11141-94504	GASKET, cylinder head	1	304395-304534
22-3	11141-94505	GASKET, cylinder head	1	304535~

FIG.1

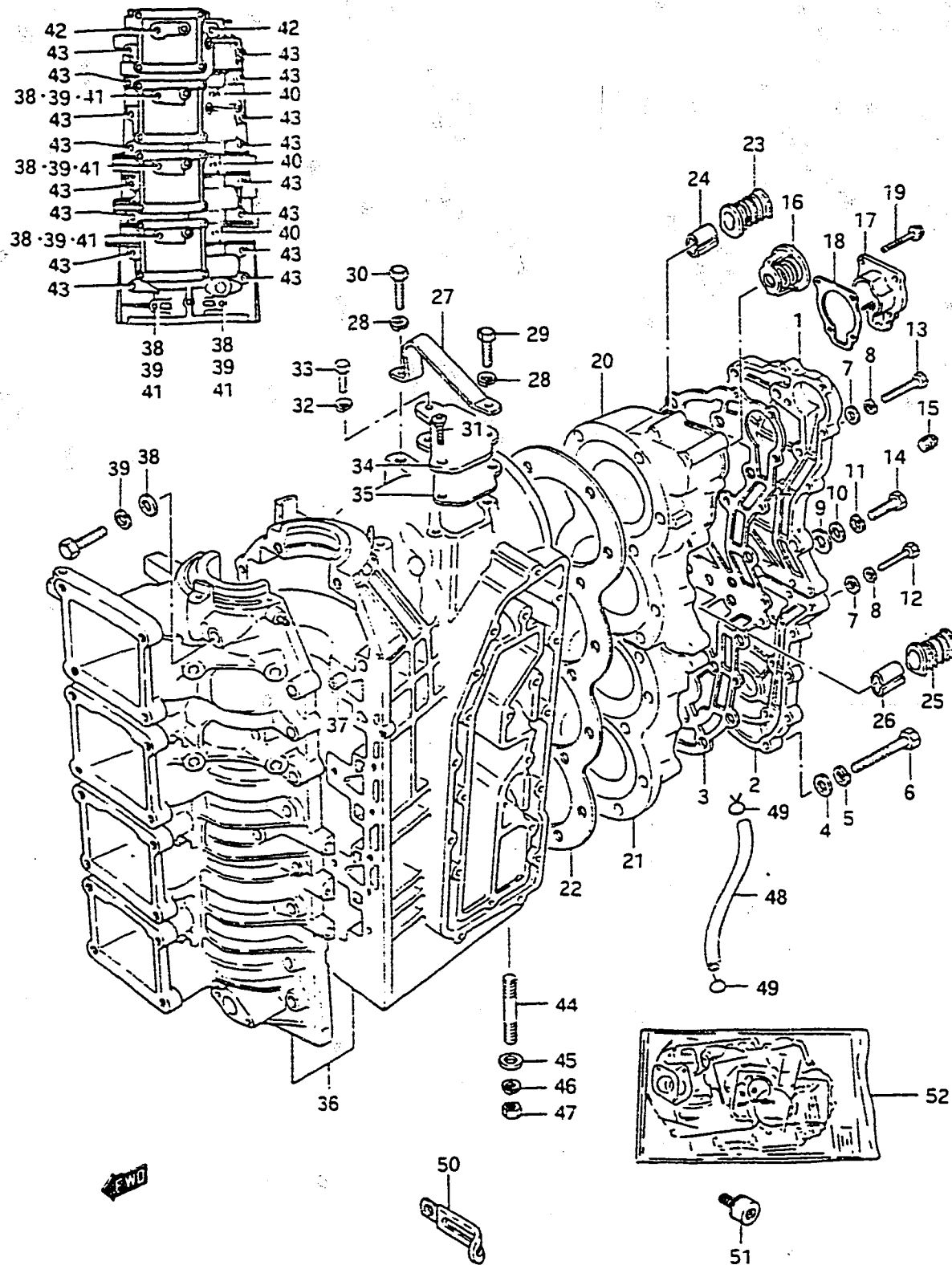


FIG.1 ( B-3) CRANKCASE

REF.NO.	PART NO.	DESCRIPTION	Q'TY	REMARKS
23	11181-94500	CONNECTOR, head	1	
24	11182-94500	INSERTER	1	
25	11171-94500	CONNECTOR, head	1	
26	11172-94500	INSERTER	1	
27	11291-94501	HOOK, engine rear	1	
28	08321-21082	LOCK WASHER	2	
29	01107-08202	BOLT	1	
30	01107-08252	BOLT	1	
31	02132-06208	SCREW	1	
32	08321-21062	LOCK WASHER	1	
33	01107-06202	BOLT	1	
34	11218-94503	COVER, water jacket	1	
35	11219-94503	GASKET, cover	1	
36-1	11300-94504-02M	CYLINDER/CRANKCASE ASSY	1	~404581
36-2	11300-94506-02M	CYLINDER/CRANKCASE ASSY	1	404582~
37	09206-11001	.DOWEL PIN	2	
38	08322-11102	.WASHER	10	
39	08321-21102	.LOCK WASHER	10	
40	01107-10552	.BOLT	3	
41	01107-10702	.BOLT	5	
42	01107-10802	.BOLT	2	
43	01517-08402	.BOLT	16	
44	09108-10026	.STUD BOLT	2	
45	08322-11102	WASHER	2	
46	09162-10005	LOCK WASHER	2	
47	09140-10015	NUT	2	
48-1	09343-03051	HOSE, inspection (L:330→180)	1	~404581
48-2	09343-05044	HOSE, inspection (L:1425→180)	1	404582-404988
48-3	09343-05137	HOSE, inspection (L:500→135)	1	404989~
49	09401-08410	CLIP	2	
50	09404-06401	CLAMP, oil hose	1	
51	55320-93142	ZINC, cylinder	1	
52	11400-94843	GASKET SET	1	

FIG.2

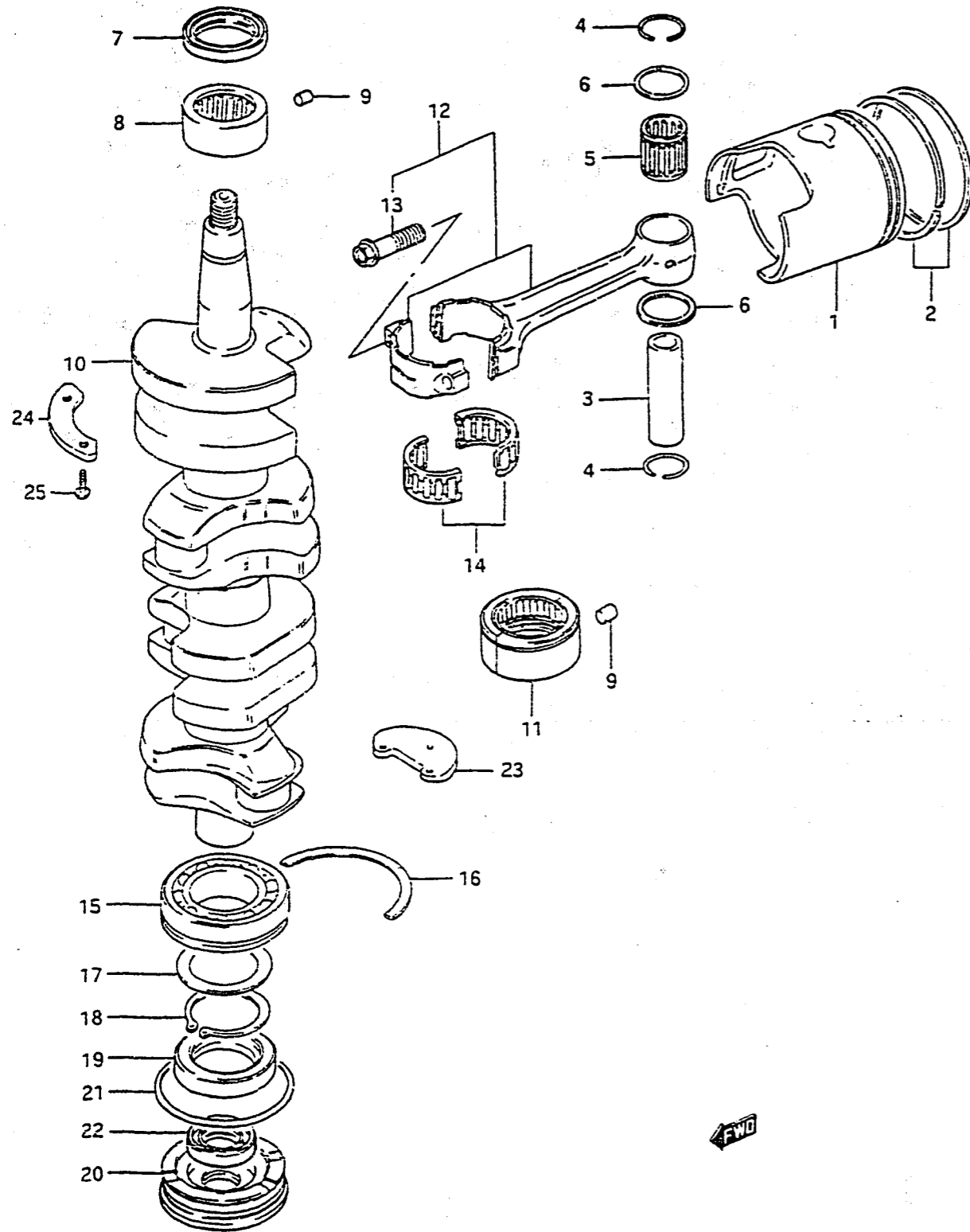


FIG.2 ( B- 4) CRANKSHAFT

Q'TY

REF.NO.	PART NO.	DESCRIPTION	Q'TY	REMARKS
1-1	121'0-94511	PISTON	4	STD,~304393
1-2	12110-94512	PISTON	4	STD,304394~
1-3	12110-94511-025	PISTON (OS:0.25)	4	OPT,~304393
1-4	12110-94512-025	PISTON (OS:0.25)	4	OPT,304394~
1-5	12110-94511-050	PISTON (OS:0.5)	4	OPT,~304393
1-6	12110-94512-050	PISTON (OS:0.5)	4	OPT,304394~
2-1	12140-95310	RING SET, piston	4	STD,~304327
2-2	12140-95311	RING SET, piston	4	STD,304328~
2-3	12140-95310-025	RING SET, piston (OS:0.25)	4	OPT,~304327
2-4	12140-95311-025	RING SET, piston (OS:0.25)	4	OPT,304328~
2-5	12140-95310-050	RING SET, piston (OS:0.5)	4	OPT,~304327
2-6	12140-95311-050	RING SET, piston (OS:0.5)	4	OPT,304328~
3	12151-94501	PIN, piston	4	
4	09381-22002	CIRCLIP	8	
5	09263-22030	BEARING, piston pin	4	
6	08211-22361	WASHER	8	
7	09283-40008	OIL SEAL, upper	1	
8	09263-40003	BEARING, upper	1	
9	04221-04089	DOWEL PIN	4	
10	12220-94508	CRANKSHAFT	1	
11	09269-40002	BEARING, middle	3	
12-1	12160-94507	ROD ASSY, connecting	4	model QD
12-2	12160-94510	ROD ASSY, connecting	4	model VE/VF
13	09119-08045	.BOLT, rod	8	
14-1	09263-35012	BEARING, crank pin	4	model QD
14-2	09263-35016	BEARING, crank pin	4	model VE/VF
15	09262-40003	BEARING, lower	1	
16	09390-80002	C RING	1	
17	09160-40004	WASHER (40x55x1.5)	1	
18	08331-31409	CIRCLIP	1	

FIG.2

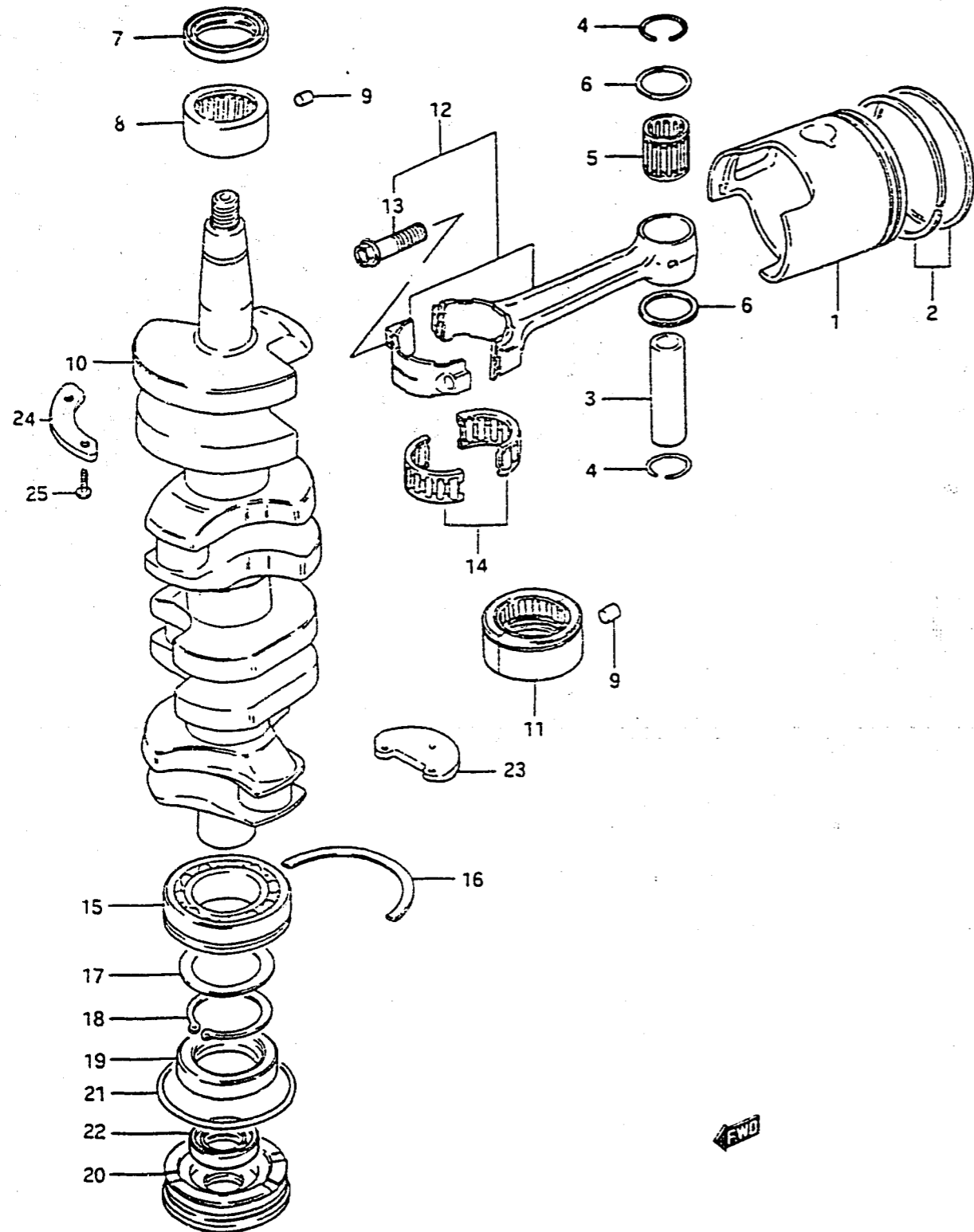
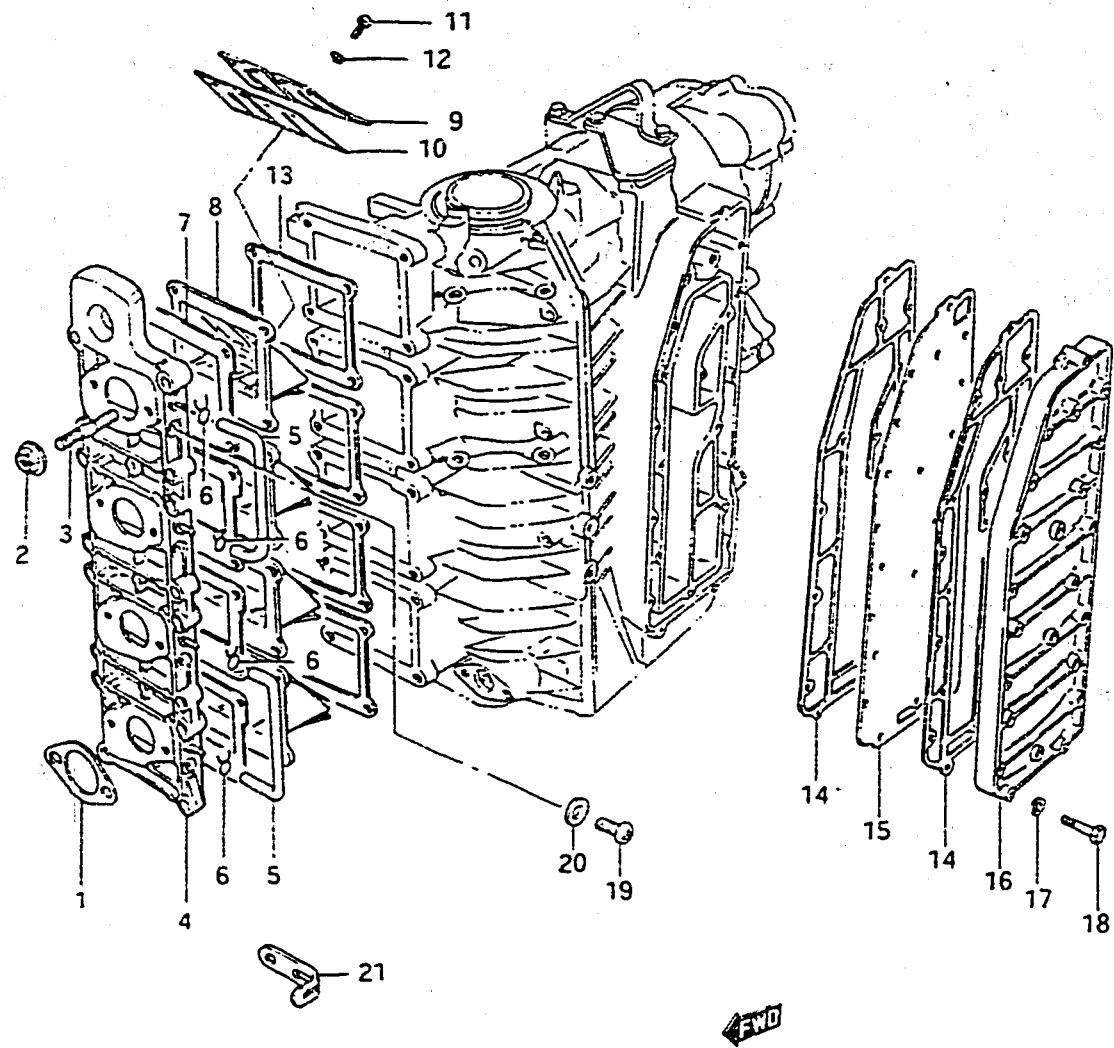


FIG.2 ( B- 5) CRANKSHAFT

REF.NO.	PART NO.	DESCRIPTION	Q'TY	REMARKS
19	09283-40066	OIL SEAL, lower	1	
20	11431-94502	HOUSING, oil seal	1	
21	09280-70006	O RING	1	
22	09282-24002	OIL SEAL, driveshaft upper	1	
23	12271-94501	BALANCE WEIGHT, lower	1	
24	12272-94500	BALANCE WEIGHT, upper	1	
25	02122-06258	SCREW	2	

FIG.3

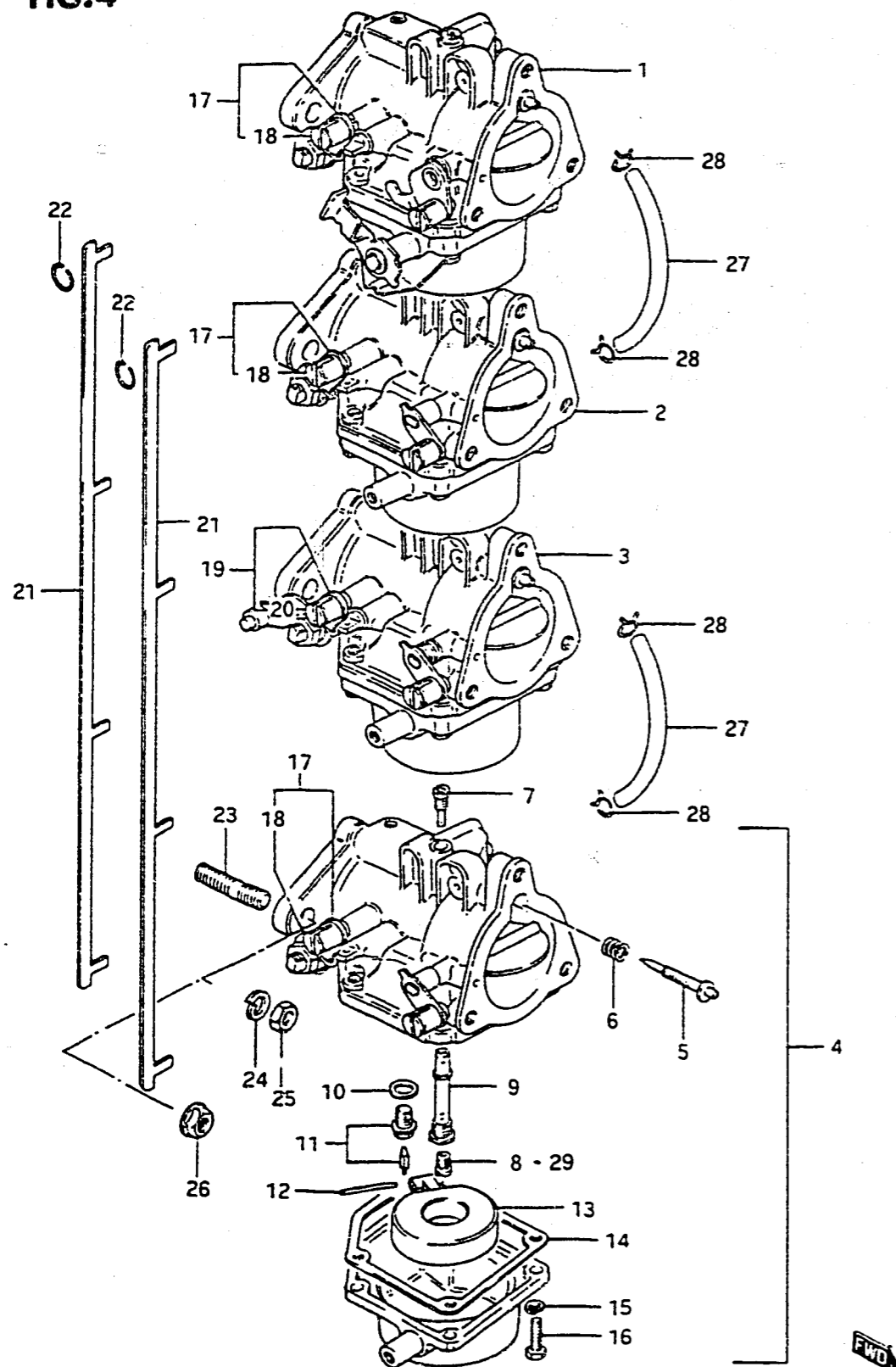
FIG.3 ( B- 6) INLET - EXHAUST COVER



REF.NO.	PART NO.	DESCRIPTION	Q'TY	REMARKS
1	13125-93000	GASKET	4	
2	08316-16088	NUT	16	
3	01421-08358	STUD BOLT	16	
4	13110-94504	CASE, inlet	1	
5	09343-03051	HOSE, inlet case (L:140)	2	
6	09401-06403	CLIP, hose	4	
7	13121-94500	GASKET, inlet case	4	
8	13150-94501	VALVE ASSY, reed	4	
9	13152-94501	.STOPPER	16	
10	13153-94500	.VALVE, reed	16	
11	02112-03088	.SCREW	32	
12	08321-21038	.LOCK WASHER	32	
13	13156-94500	GASKET, reed valve	4	
14	14151-94500	GASKET, exhaust cover	2	
15	14131-94503	PLATE, exhaust	1	
16	14141-94500-02M	COVER, exhaust	1	
17-1	08321-21062	LOCK WASHER	20	model QD/VE
17-2	08321-21062	LOCK WASHER	23	model VF
18-1	09100-06033	BOLT	20	model QD
18-2	01107-06352	BOLT	20	model VE
18-3	01107-06352	BOLT	23	model VF
19	09125-06020	SCREW	1	
20	09168-06023	GASKET	1	
21-1	09404-08401	CLAMP	1	model QD
21-2	09404-08201	CLAMP	1	model VE/VF

FIG.4

FIG.4 ( B- 7) CARBURETOR



REF.NO.	PART NO.	DESCRIPTION	Q'TY	REMARKS
1-1	13201-94502	CARBURETOR, top	1	~406280
1-2	13201-94570	CARBURETOR, top	1	506281~
2-1	13202-94503	CARBURETOR, 2nd	1	~406280
2-2	13202-94570	CARBURETOR, 2nd	1	506281~
3-1	13203-94501	CARBURETOR, 3rd	1	~406280
3-2	13203-94570	CARBURETOR, 3rd	1	506281~
4-1	13204-94504	CARBURETOR, 4th	1	~406280
4-2	13204-94570	CARBURETOR, 4th	1	506281~
5	13269-93311	.ADJUSTOR	4	
6	13271-93311	.SPRING	4	
7-1	09492-75001	.PILOT JET (75)	4	~406280
7-2	09492-82002	.PILOT JET (82.5)	4	506281~
8	09491-27008	.MAIN JET (135)	4	
9	13235-95210	.NOZZLE	4	
10	13392-58600	.GASKE1, valve seat	4	
11	13370-28110	.VALVE, needle	4	
12	13254-93010	.PIN	4	
13	13250-93012	.FLOAT	4	
14	13251-93310	.GASKE1	4	
15	09162-05002	.LOCK WASHER	16	
16	13281-94500	.BOLT	16	
17	13513-94511	.LEVER, throttle	3	
18	13542-94500	..CONNECTOR	6	
19	13511-94510	.LEVER, throttle	1	
20	13542-94500	..CONNECTOR	2	
21	13541-94510	.PLATE	2	
22	13579-98100	.CIRCLIP	8	

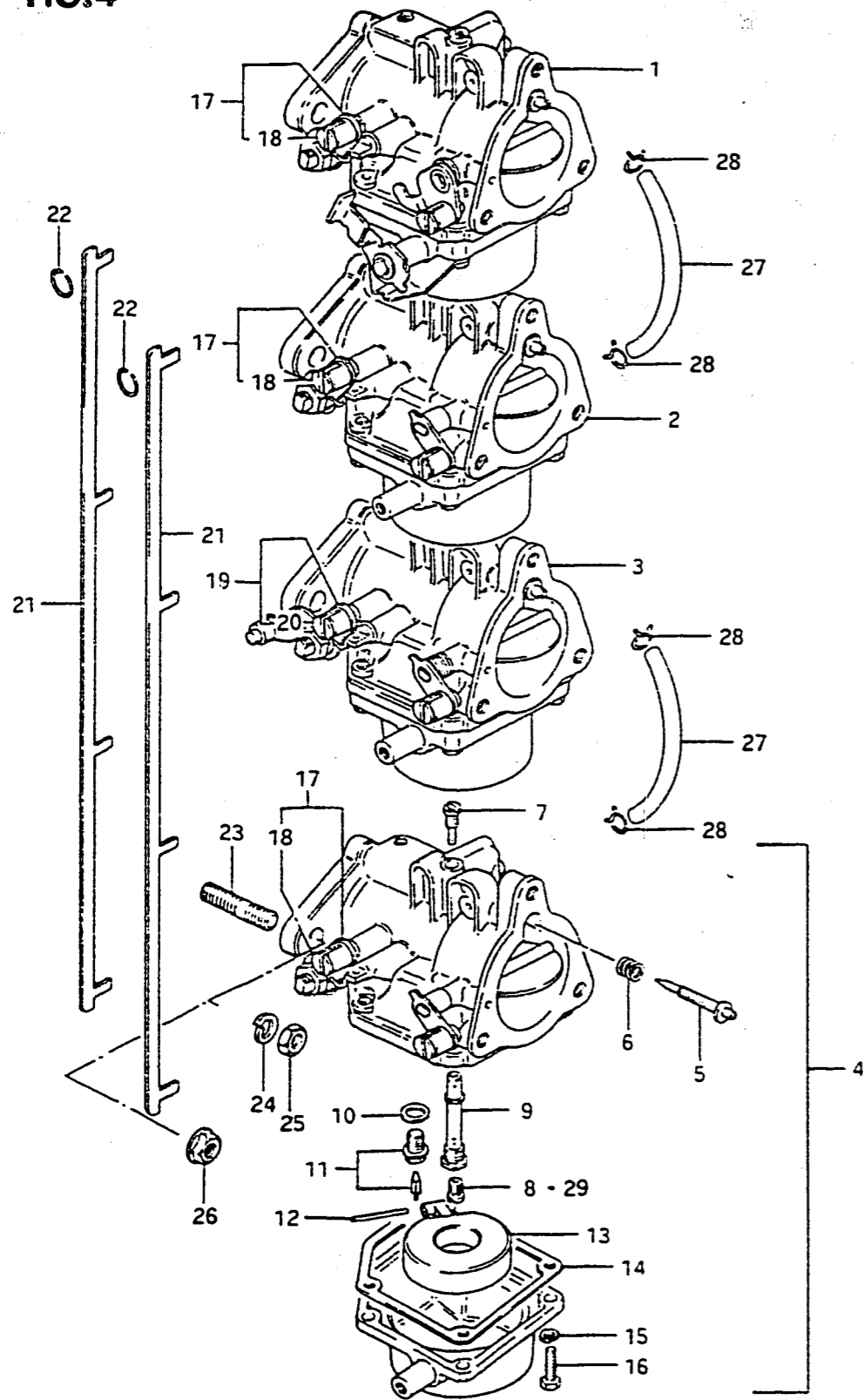
See Frames A-7 and A-8 for additional optional jet part numbers.



FIG.4

FIG.4 ( B- 8) CARBURETOR

Q'TY



REF.NO.	PART NO.	DESCRIPTION	Q'TY	REMARKS
23	01411-08202	STUD BOLT	8	
24	08321-21082	LOCK WASHER	8	
25	08310-22082	NUT	8	
26	08316-16082	NUT	8	
27	09343-05137	HOSE, fuel	2	L:500→135
28	09401-08410	CLIP, fuel hose	4	
29-1	09491-26009	MAIN JET (130)	4	OPT
29-2	09491-28007	MAIN JET (140)	4	OPT
29-3	09491-25002	MAIN JET (125)	4	OPT

See Frames A-7 and A-8 for additional optional jet part numbers.

FIG.5

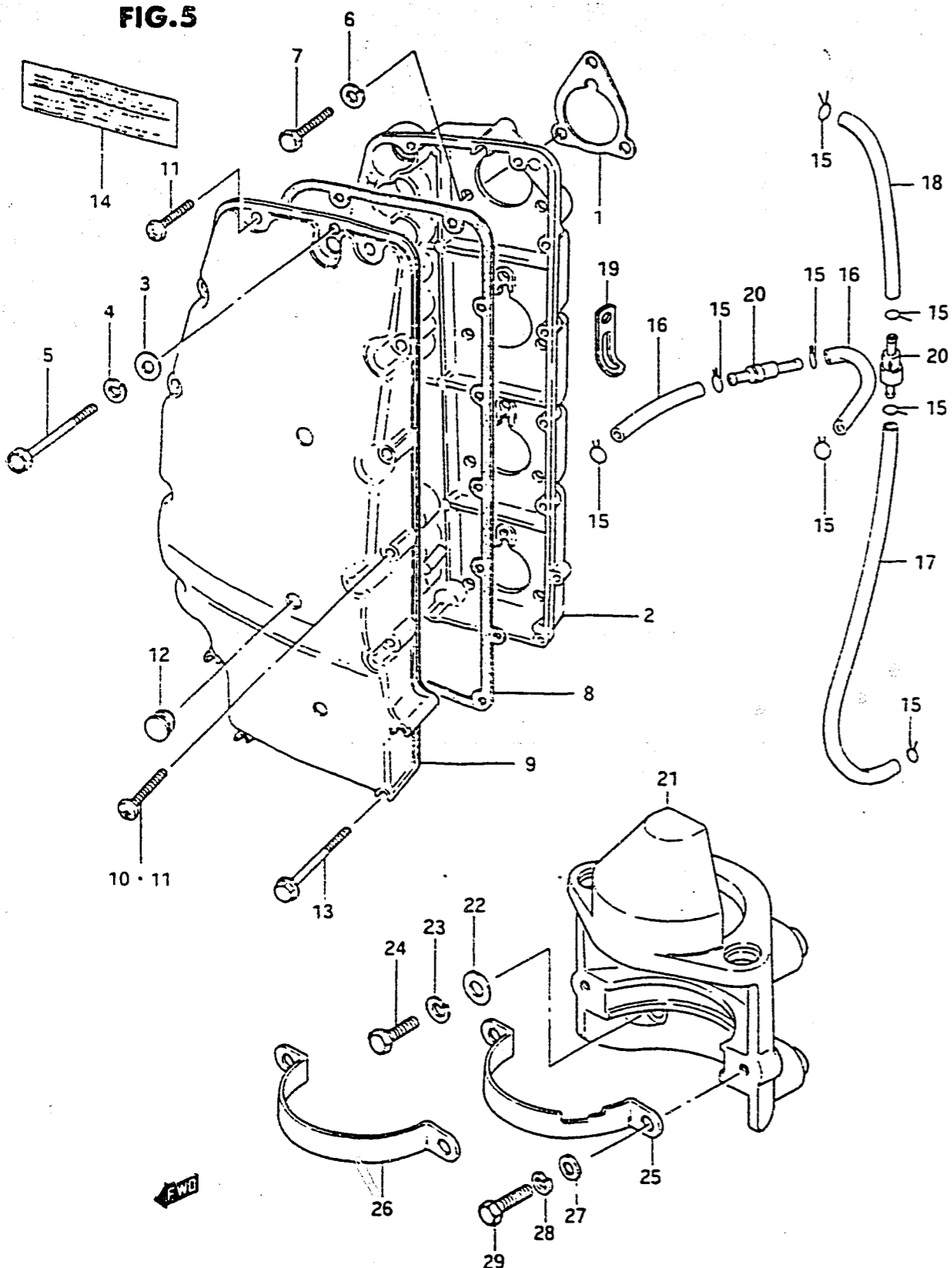


FIG.5 ( B- 9) SILENCER - MOTOR BRACKET

REF.NO.	PART NO.	DESCRIPTION	Q'TY	REMARKS
1	13855-93300	GASKE1, silencer	4	
2	13811-94503	CASE, silencer	1	
3	08322-21062	WASHER	1	
4	08321-21062	LOCK WASHER	1	
5-1	09100-06038	BOLT (6x65)	1	model QD
5-2	01107-06652	BOLT (6x65)	1	model VE/VF
6	08321-21062	LOCK WASHER	11	
7	01107-06162	BOLT	11	
8	13853-94500	GASKET, silencer cover	1	
9-1	13812-94503	COVER, silencer	1	model QD/VE
9-2	13812-94504	COVER, silencer	1	model VF
10	02152-05202	SCREW	4	
11	02152-05352	SCREW	6	
12-1	09250-10010	PLUG	4	model QD/VE
12-2	09250-15010	PLUG	4	model VF
13	01514-05452	BOLT	4	
14	61458-95204	MARK, safety warning	1	model QD
15	09401-06403	CLIP	4	
16	09343-03051	HOSE (lubrication / silencer)	2	model QD
17	09343-03039	HOSE, lubrication	1	model VE/VF,L:400
18	09343-03051	HOSE, lubrication	1	model VE/VF,L:330-120
19	09404-08402	CLAMP, lubrication hose	1	
20	16710-95200	CHECK VALVE	1	
21	31911-94514-02M	BRACKET, starting motor	1	
22	08322-11082	WASHER	4	
23	08321-21082	LOCK WASHER	4	
24	01107-08252	BOLT	4	
25	31912-94511	BAND, starter	1	model QD/VE
26	31912-94600	BAND, starter	1	model VF
27	08322-11082	WASHER	2	model QD
28	08321-21082	LOCK WASHER	2	
29	01107-08252	BOLT	2	

DT115TC VF E3

DT115TC VF E3

FIG.6

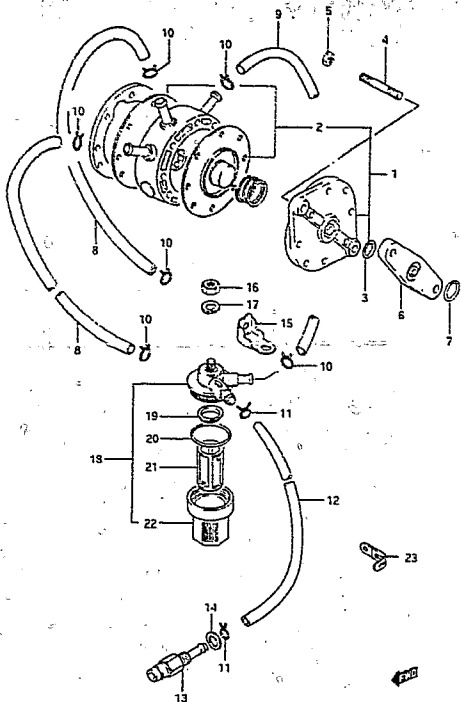


FIG.6 (B-10) FUEL PUMP

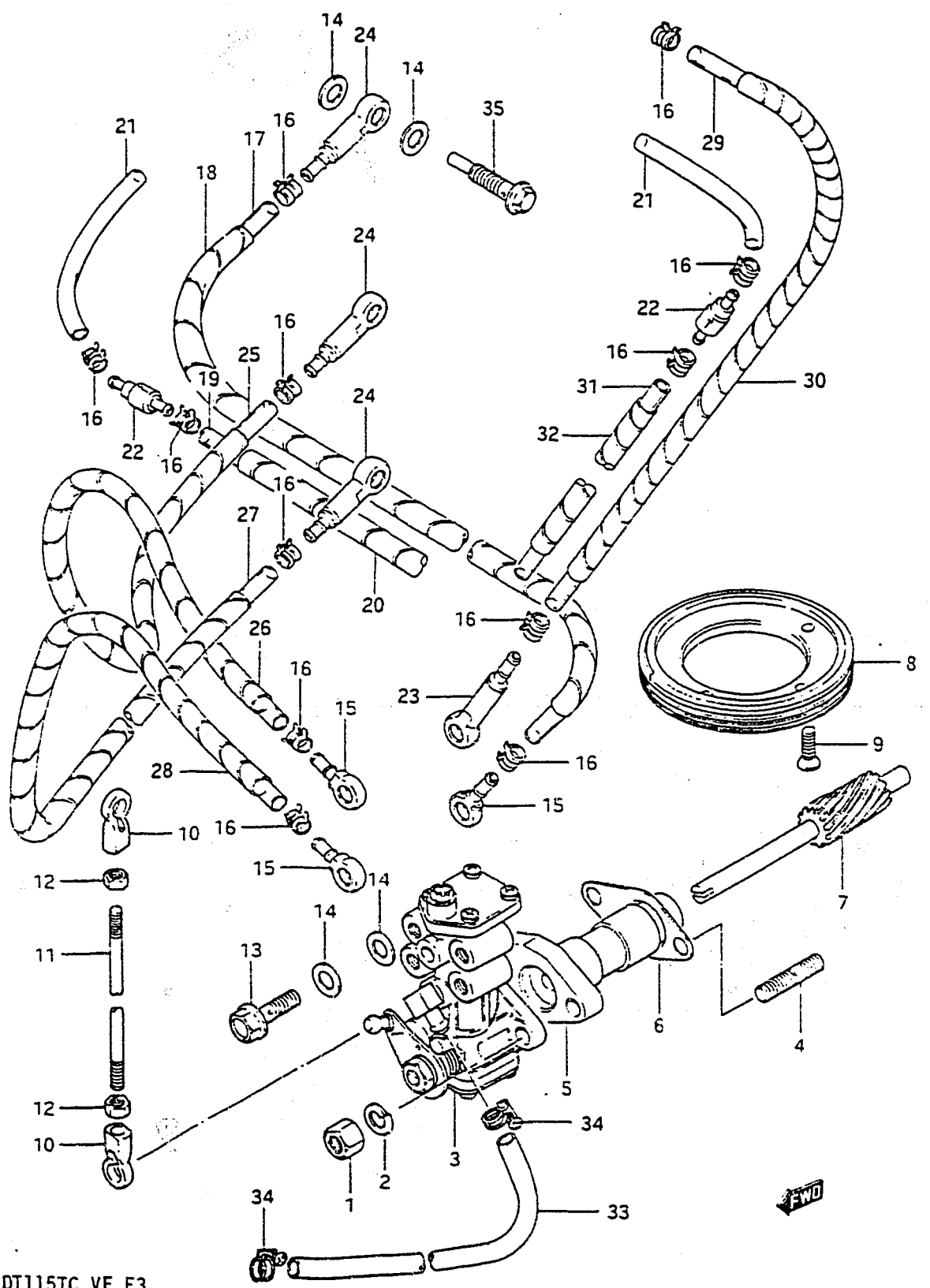
REF.NO.	PART NO.	DESCRIPTION	Q'TY	REMARKS
1	15100-94502	PUMP ASSY, fuel	1	
2	15170-72812	.DIAPHRAGM SET	1	
3	15165-93010	.O RING	1	
4	01421-06352	STUD BOLT	2	
5	08316-16062	NUT	2	
6	15322-93000	INSULATOR	1	
7	09280-12005	O RING	1	
8	09343-07053	HOSE, fuel (pump+carburetor)	2	L:655+470
9	09343-07053	HOSE, fuel (filter+pump)	1	L:655+110
10	09401-11402	CLIP	6	
11	09401-11402	CLIP	2	
12	09343-07113	HOSE, fuel (connector+filter)	1	L:160
13	65720-95511	CONNECTOR, male fuel	1	00:13
14	09161-12004	WASHER	1	
15	15421-94501-024	BRACKET, fuel filter	1	
16	08310-22082	NUT	1	
17	08371-71082	LOCK WASHER	1	
18	15410-95510	FILTER, fuel	1	
19	15416-93400	.PACKING	1	
20	15415-93400	.O RING	1	
21	15412-93400	.STRAINER	1	
22	15413-93400	.CUP	1	
23	09404-06201	CLAMP	1	

FIG.7

FIG.7 ( B-11) OIL PUMP (~304574)

Q'TY

REF.NO.	PART NO.	DESCRIPTION	Q'TY	REMARKS
1	09140-06013	NUT	2	
2	09162-06001	LOCK WASHER	2	
3	16100-94502	PUMP, oil	1	
4	01421-06302	STUD BOLT	2	
5	16340-94501	RETAINER, driven gear	1	
6	16731-95500	GASKET	1	
7	16331-94500	GEAR, driven	1	
8	16321-94501	GEAR, drive	1	
9	02122-06308	SCREW	3	
10	19131-95502	CONNECTOR	2	
11	16411-94502	ROD, control	1	
12	09140-05001	NUT	2	
13	09360-06012	BOLT, union	4	
14	09168-06023	GASKET (6.5x12x1.4)	14	
15	09363-02002	UNION, outlet	3	
16-1	09401-06405	CLIP	8	~304157
16-2	09401-06405	CLIP	12	304158~
17	09344-02013	HOSE, outlet (2)	1	L:420→270,~304157
18	16911-94500	PROTECTOR (2)	1	L:390→240,~304157
19	09344-02013	HOSE, outlet (2)	1	L:420→210,304158~
20	16911-94500	PROTECTOR (2)	1	L:390→180,304158~
21	09344-02004	HOSE, outlet	2	L:50,304158~
22	16710-94520	CHECK VALVE	2	304158~
23	16710-94510	CHECK VALVE	1	
24	16710-94502	CHECK VALVE	3	



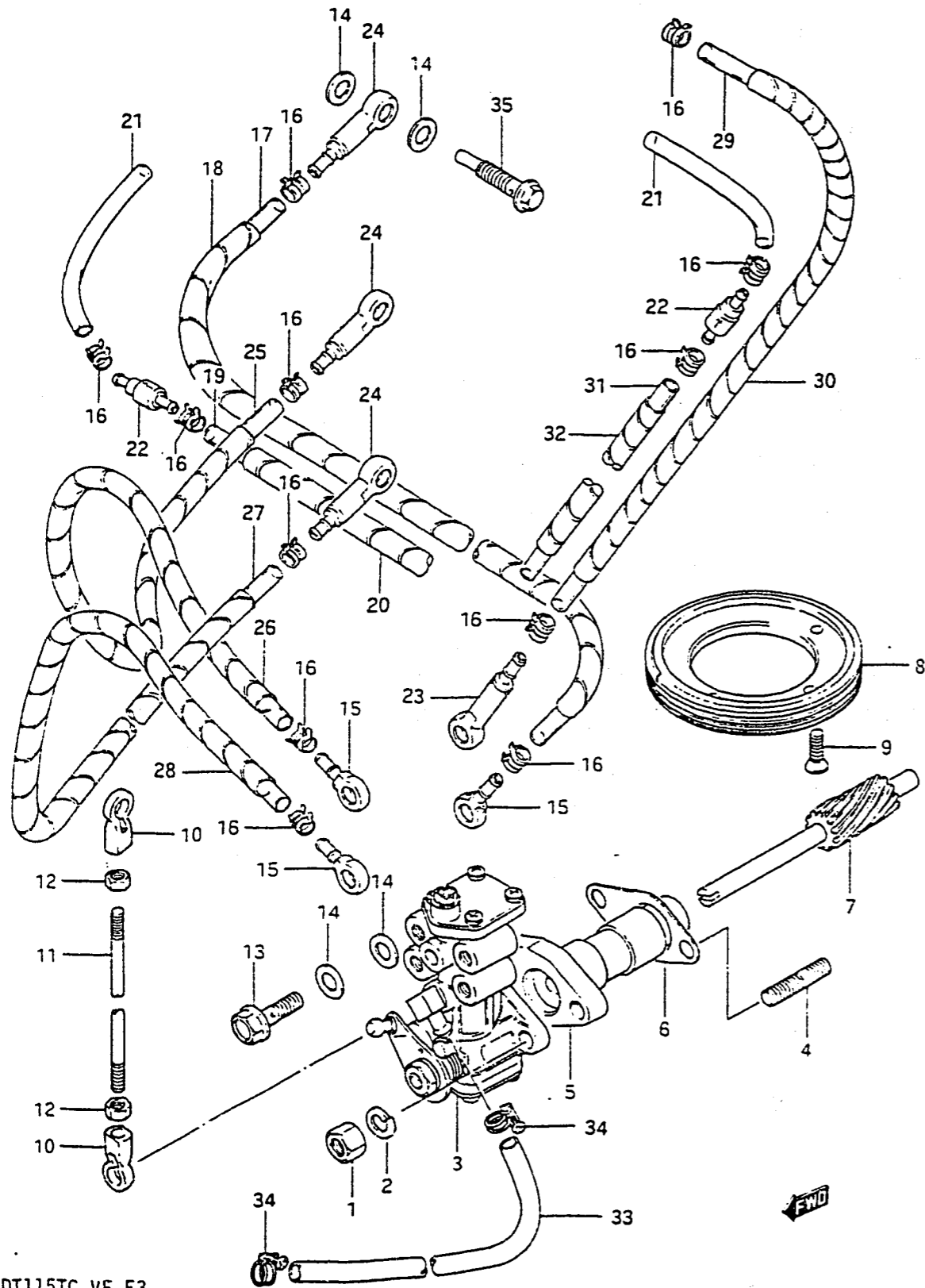
Refer to FIG.8 (B-13) for 404575~

FIG. 7

FIG. 7 ( B-12) OIL PUMP (~304574)

Q'TY

REF.NO.	PART NO.	DESCRIPTION	Q'TY	REMARKS
25	09344-02013	HOSE, outlet (3)	1	L:420→210
26	16911-94500	PROTECTOR (3)	1	L:390→180
27	09344-02013	HOSE, outlet (4)	1	L:420→320
28	16911-94500	PROTECTOR (4)	1	L:390→290
29	09344-02013	HOSE, outlet (1)	1	L:420,~304157
30	16911-94500	PROTECTOR (1)	1	L:390,~304157
31	09344-02013	HOSE, outlet (1)	1	L:420→370,304158~
32	16911-94500	PROTECTOR (1)	1	L:390→340,304158~
33	09344-05014	HOSE, inlet	1	L:950→330
34	09400-10302	CLAMP, inlet hose	2	
35	09360-06009	BOLT, oil nozzle	3	



Refer to FIG.8 (B-13) for 404575~

FIG. 8

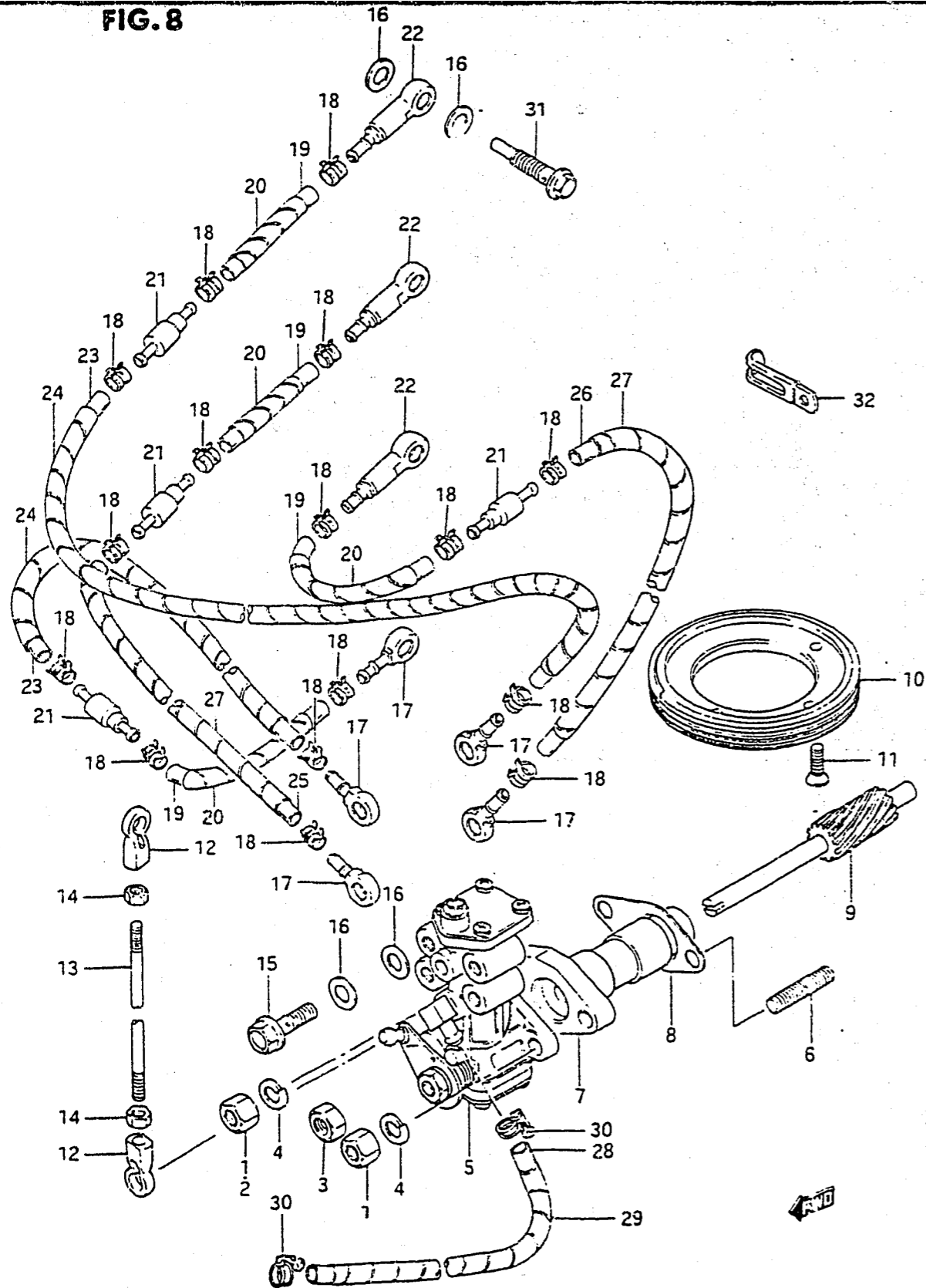


FIG. 8 ( B-13) OIL PUMP (404575~)

REF.NO.	PART NO.	DESCRIPTION	Q'TY	REMARKS
1	09140-06013	NUT	2	model VE
2	09140-06013	NUT	1	model VF
3	08310-11062	NUT	1	model VF
4	09162-06001	LOCK WASHER	2	
5	16100-94506	PUMP, oil	1	
6	01421-06302	STUD BOLT	2	
7	16340-94501	RETAINER, driven gear	1	
8	16731-95500	GASKET	1	
9	16331-94500	GEAR, driven	1	
10	16321-94501	GEAR, drive	1	
11	02122-06308	SCREW	3	
12	19131-95502	CONNECTOR	2	
13	16411-94502	ROD, control	1	
14	09140-05001	NUT	2	
15	09360-06012	BOLT, union	4	
16	09168-06023	GASKET (6.5x12x1.4)	16	
17	09363-02002	UNION, outlet	5	
18	09401-06405	CLIP	16	
19	09344-02004	HOSE, outlet	4	L:50
20	16911-94500	PROTECTOR	4	L:390→40
21	16710-94531	CHECK VALVE	4	
22	16710-94502	CHECK VALVE	3	
23	09344-02013	HOSE, outlet (1&4)	2	L:420→270
24	16911-94500	PROTECTOR (1&4)	2	L:390→240
25	09344-02015	HOSE, outlet (2)	1	L:220→160
26	09344-02013	HOSE, outlet (3)	1	L:420→175
27	16911-94500	PROTECTOR (2&3)	2	L:390→180
28	09344-05014	HOSE, inlet	1	L:950→330
29	16911-94500	PROTECTOR	1	L:390→290
30	09400-10302	CLAMP, inlet hose	2	
31	16715-94501	BOLT, oil nozzle	4	
32	09404-08201	CLAMP	2	

Refer to FIG. 7 (B-11.12) for ~304574

FIG. 9

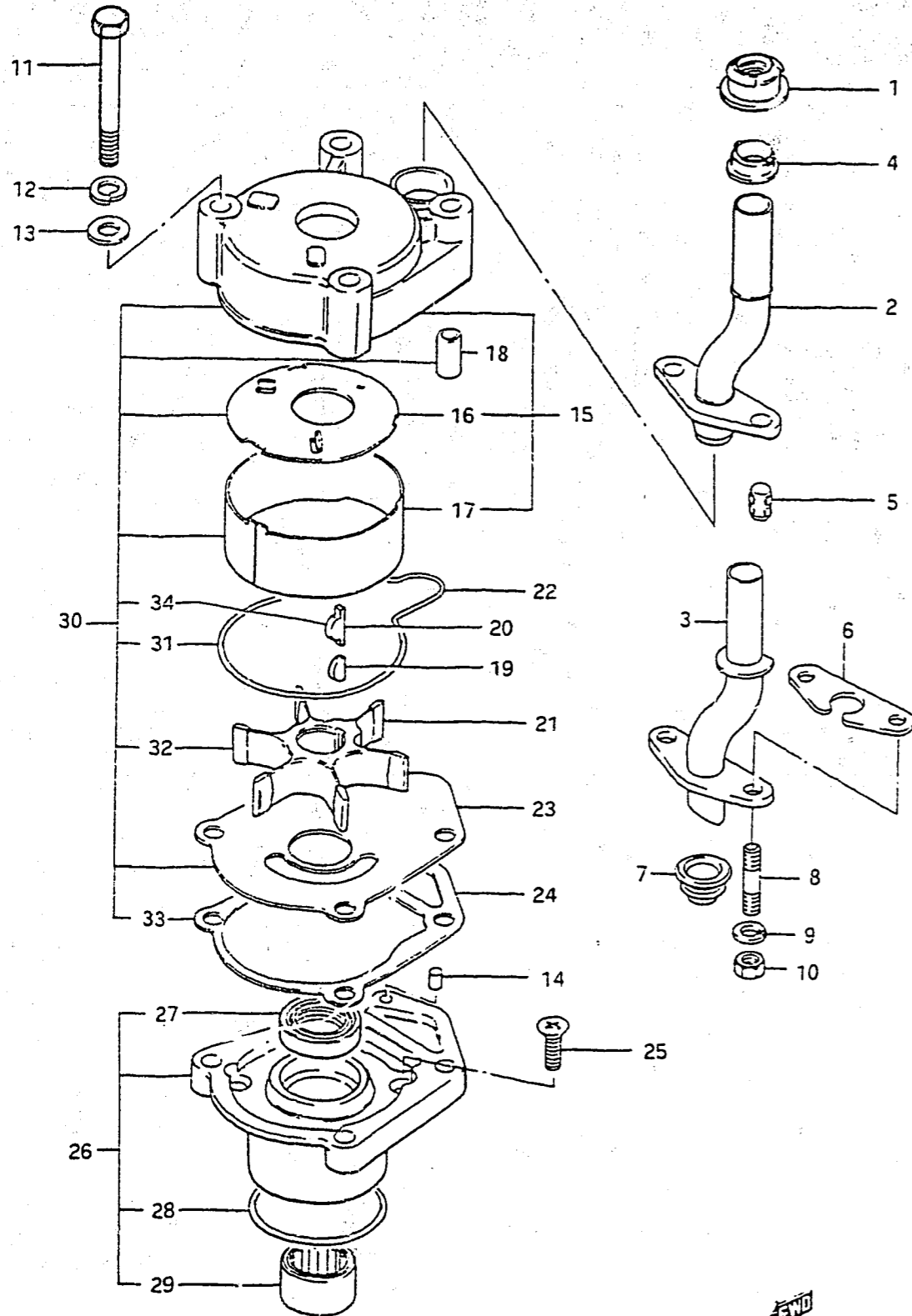


FIG. 9 ( B-14) WATER PUMP

REF.NO.	PART NO.	DESCRIPTION	Q'TY	REMARKS
1	17563-94501	BUSHING, upper	1	
2-1	17560-94502	TUBE, water (L)	1	~405973
2-2	17560-94511	TUBE, water (X)	1	~405973
3-1	17560-94520	TUBE, water (L)	1	405974~
3-2	17560-94530	TUBL, water (X)	1	405974~
4	09306-16002	BUSHING, guide	1	
5	09250-09004	CAP, tube plate	2	~405973
6	17567-94500	GASKET	1	405974~
7	09305-16004	BUSH	1	405974~
8	09108-06060	STUD BOLT	2	405974~
9	09162-06006	LOCK WASHER	2	405974~
10	09140-06020	NUT	2	405974~
11	09100-08169	BOLT	4	
12	09162-08007	LOCK WASHER	4	
13	09160-08059	WASHER (8.5x18x1.6)	4	
14	09202-04008	PIN	1	
15	17410-94504	CASE, water pump	1	
16	17412-94500	.PANEL, upper	1	
17	17413-94502	.SLEEVE, case	1	
18-1	09206-11008	.PIN	4	~404963
18-2	09206-11009	.PIN	4	404964~
19	09420-05004	KEY	1	~405598
20	09420-05005	KEY	1	405599~
21	17461-94504	IMPELLER	1	*SEE NOTE
22	17416-94500	SEAL RING	1	
23	17471-94501	PANEL, under	1	
24	17472-94501	GASKET, under panel	1	
25	09126-06006	SCREW	4	

\* NOTE

When you use the impeller (17461-94504) up to E.No.405598, please be sure to use with the key (09420-05005).



FIG. 9

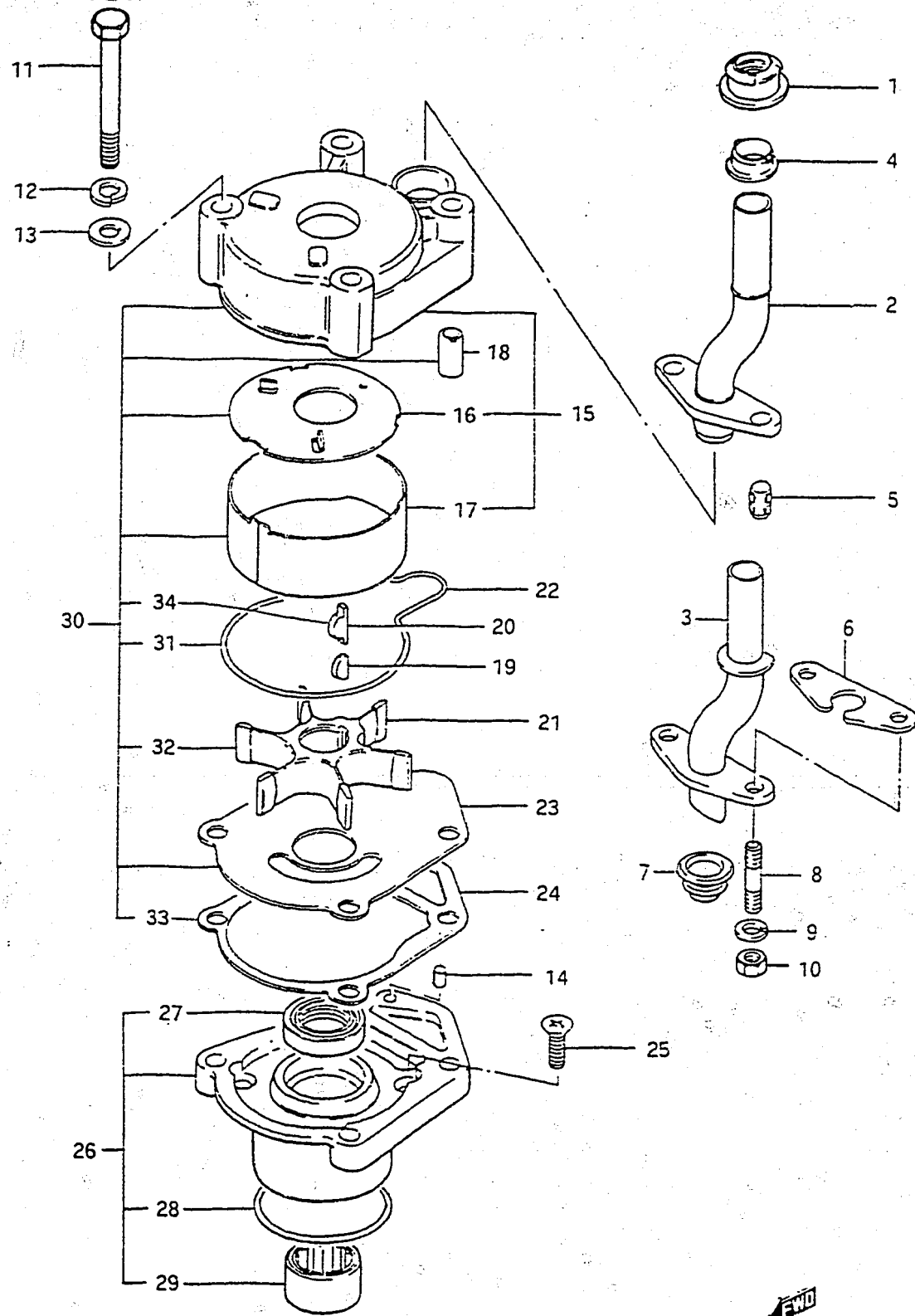


FIG. 9 ( B-15) WATER PUMP

REF.NO.	PART NO.	DESCRIPTION	Q'TY	REMARKS
26	56130-94502	HOUSING, drive shaft bearing	1	
27-1	09289-24001	.OIL SEAL (24x35x10)	1	model QD
27-2	09282-24003	.OIL SEAL (24x35x6)	2	model VE/VF
28	09280-55002	.O RING	1	
29	09263-26010	.BEARING (26x34x20)	1	
30	17400-94551	KIT, water pump repair	1	OPT
31	17416-94500	.SEAL RING	1	
32	17461-94505	.IMPELLER	1	
33	17472-94501	.GASKET	1	
34	09420-05005	.KEY	1	



FIG. 10

FIG.10 ( C- 2) THROTTLE LINK

Q'TY

REF.NO.	PART NO.	DESCRIPTION	Q'TY	REMARKS
1	09119-05010	BALL PIVOT, spark advance	2	
2	19132-94501	CONNECTOR	1	
3	19211-94503	LEVER, spark advance	1	
4	09329-06002	CUSHION, screw	1	
5	09139-06015	SCREW	1	
6	09140-06004	NUT	1	
7	09443-09015	SPRING	1	
8	01421-08352	STUD BOLT	3	
9	09180-08098	SPACER (8.1x11x20.5)	3	
10	09301-11002	BUSHING, throttle lever	2	
11	09160-08055	WASHER	3	
12	09159-08018	NUT	3	
13	19136-94502	ROD, advance lever	1	
14	09140-05001	NUT	2	
15	19121-94504	LEVER, transmit	1	
16	19111-94502	LEVER, throttle control (M5)	1	
17	67413-98100	ROD, throttle cam	1	
18	19141-94502	CAM, throttle (M5)	1	
19	01421-06302	STUD BOLT	1	
20	09159-06015	NUT	1	
21	09180-06094	SPACER (6.1x9x15.5)	1	
22	09160-06062	WASHER (6.5x11.4x0.8)	1	
23	19131-94503	RETAINER, rod	2	
24	19137-94500	ROD, cable linkage	2	
25	09159-05011	TURNBUCKLE	2	
26-1	19131-95501	CONNECTOR, cam / lever	2	model QD/VE
26-2	19131-95502	CONNECTOR, cam / lever	2	model VF
27	09119-05010	BALL PIVOT (M5)	2	
28	19138-94500	CONNECTOR, lever / rod	2	
29	19139-94500	PIN	2	
30	09140-05001	NUT	2	

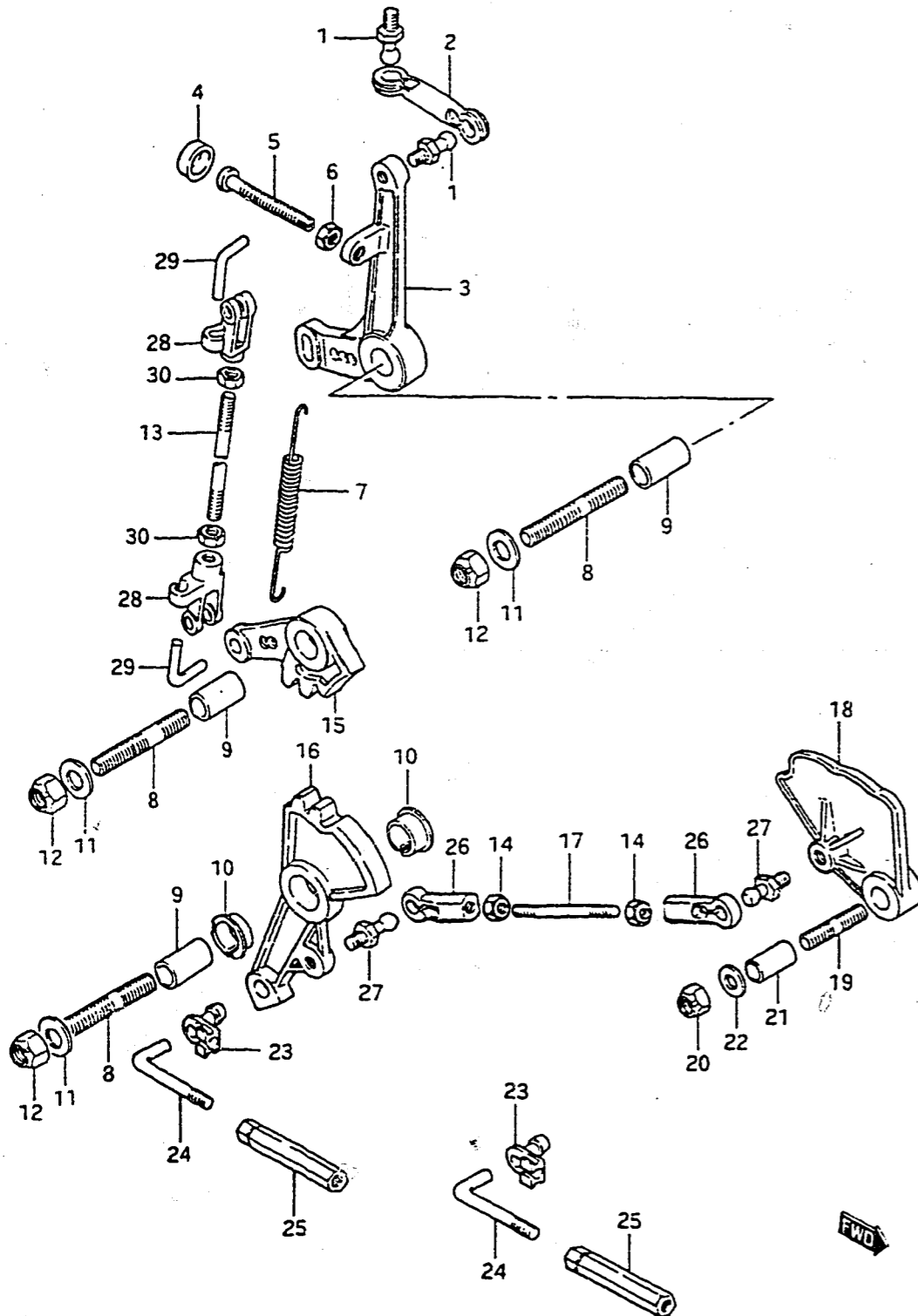


FIG. 11

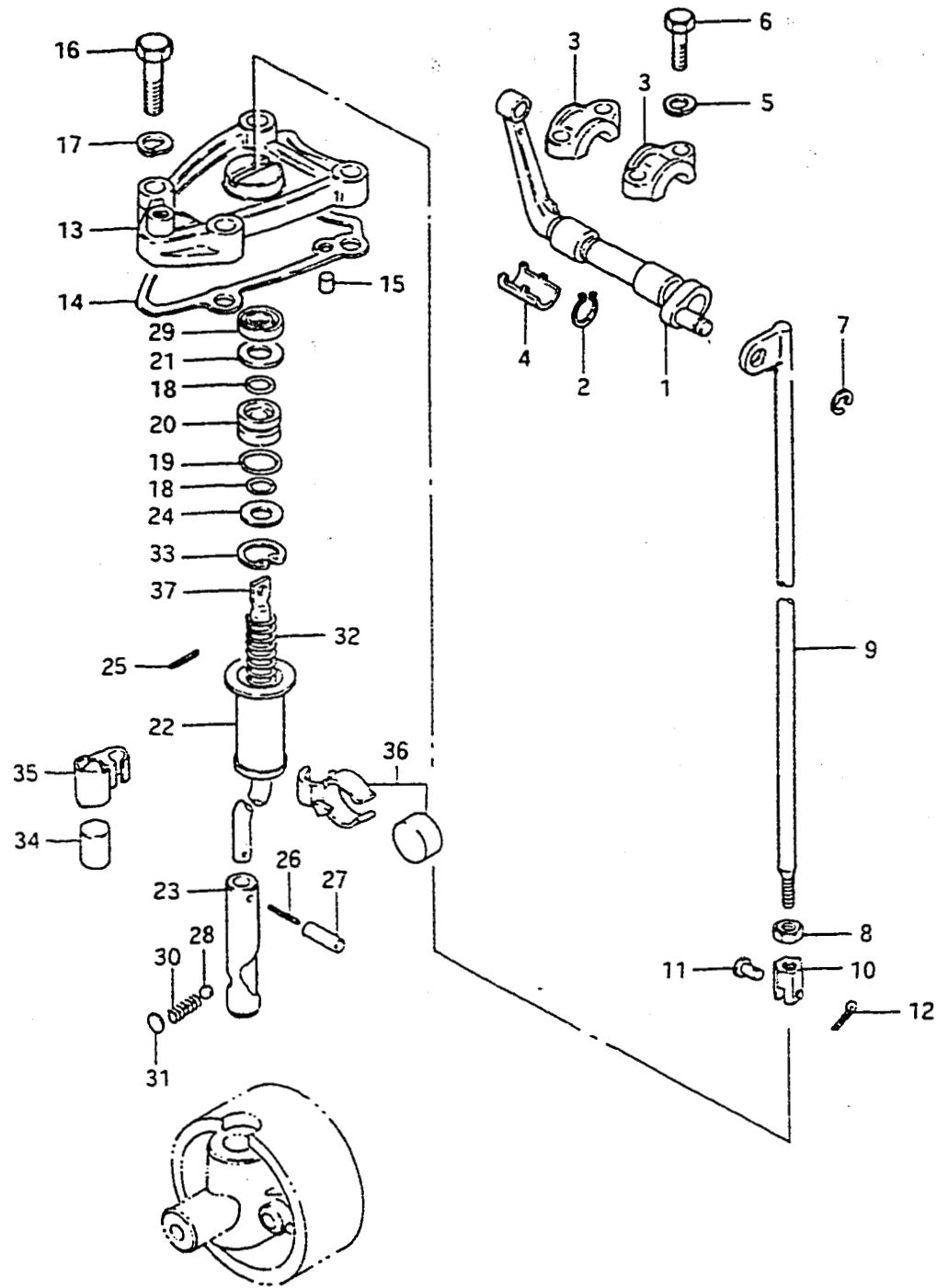


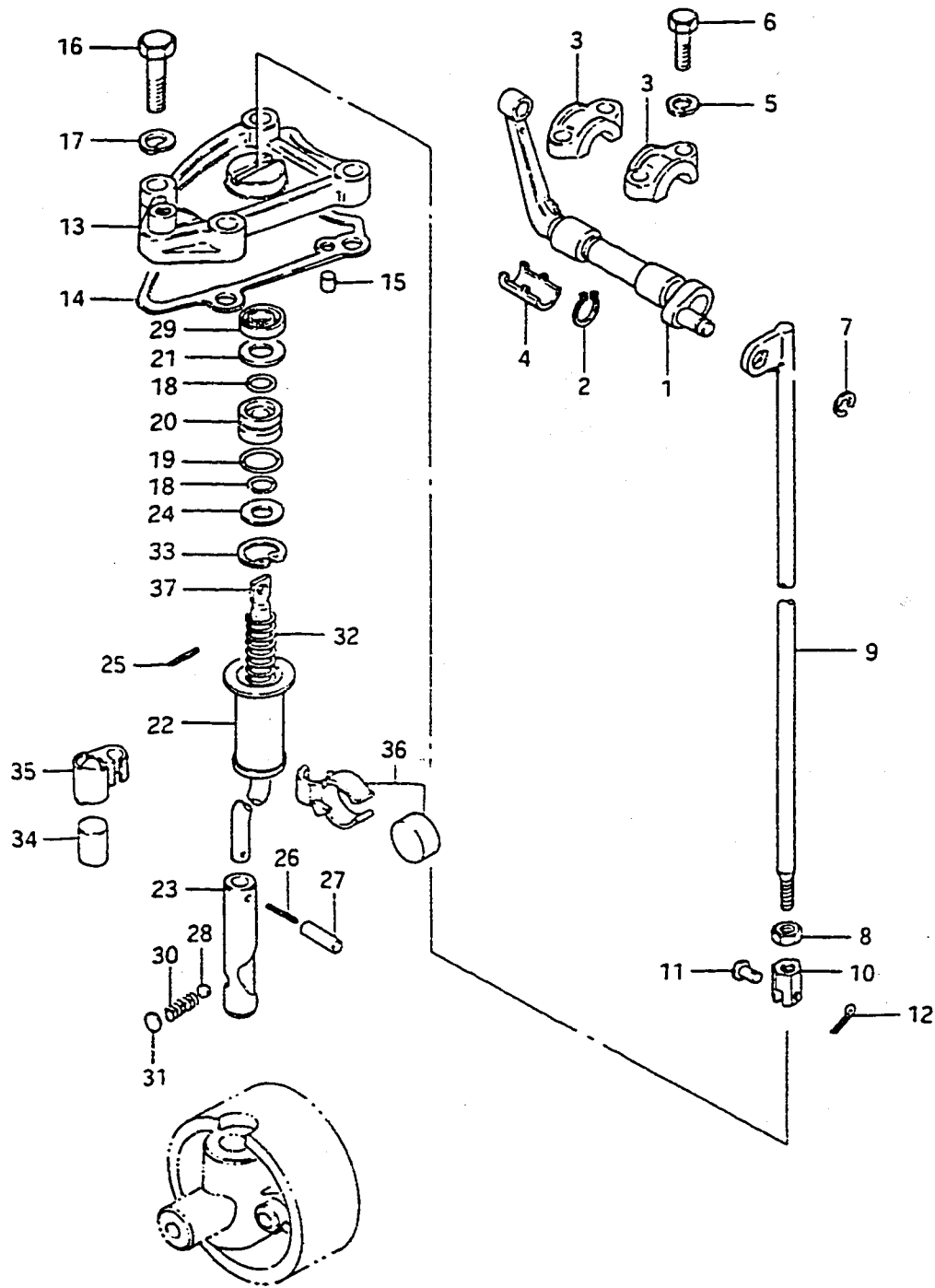
FIG. 11 ( C- 3) CLUTCH

REF.NO.	PART NO.	DESCRIPTION	Q'TY	REMARKS
1-1	21220-94503	SHAFT, clutch shift	1	-404890
1-2	21210-94500	SHAFT, clutch shift	1	404891~
2	09380-12004	.CIRCLIP	1	
3-1	21311-94502	HOLDER, shaft	2	-404890
3-2	21311-94503	HOLDER, shaft	2	404891~
4	21312-94500	BUSH	2	404891~
5	09162-06001	LOCK WASHER	4	
6	09100-06089	BOLT (6x25)	4	
7	09383-08004	E RING	1	
8-1	09140-06020	NUT (M6)	1	L type
8-2	09140-08012	NUT (M8)	1	X type
9-1	23110-94502	ROD, clutch	1	L type
9-2	23110-94510	ROD, clutch	1	X type
10-1	23315-94503	CONNECTOR, clutch rod	1	L type
10-2	23315-94510	CONNECTOR, clutch rod	1	X type
11-1	23313-94501	PIN, connector	1	L type
11-2	23313-94510	PIN, connector	1	X type
12	09204-01001	COTTER PIN	1	
13	25141-94503	HOUSING, shift rod guide	1	
14	25142-94500	GASKET	1	
15-1	06211-05103	PIN	2	model QD
15-2	04221-05109	PIN	2	model VE/VF
16	09100-08224	BOLT (8x35)	4	
17	09162-08003	LOCK WASHER	4	
18	09280-08008	O RING, inner	2	
19	09280-15003	O RING, outer	1	
20	25211-94501	GUIDE, shift rod	1	
21	09160-09009	WASHER (9x19x1)	1	
22	25205-94501	COLLAR, shift rod spring	1	
23-1	25311-94501	CAM, clutch	1	model QD
23-2	25311-94510	CAM, clutch	1	model VE/VF

FIG.11

FIG.11 ( C- 4) CLUTCH

Q'TY

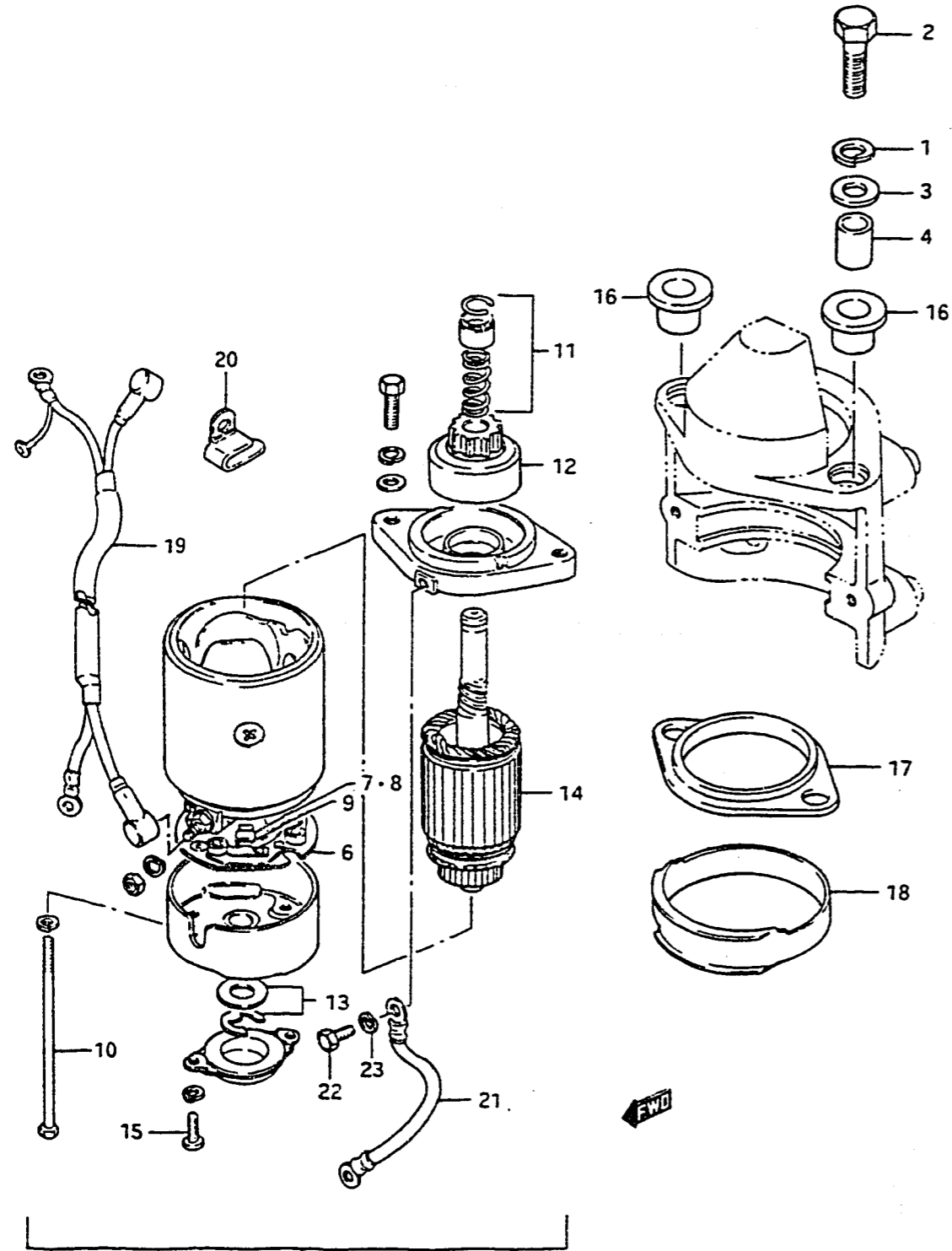


REF.NO.	PART NO.	DESCRIPTION	Q'TY	REMARKS
24	09160-09017	WASHER, lower	1	
25	09205-02004	PIN	1	
26	09205-02006	SPRING PIN	1	
27	09205-03021	SPRING PIN	1	
28-1	09260-10003	BALL, cam notch	1	model QD
28-2	09260-10005	BALL, cam notch	1	model VE/VF
29	09284-08003	DUST SEAL	1	
30	09440-07033	SPRING, cam notch	1	
31	21121-93300	PLATE, detent spring	0-1	
32	09440-12025	SPRING, shift rod	1	
33	08331-41309	CIRCLIP	1	
34	25232-95501	MAGNET	1	~304527
35	25231-95501	HOLDER, magnet	1	~304527
36	25230-94300	MAGNET SET	1	304528-
37-1	25111-94502	ROD, shift	1	L type
37-2	25111-94510	ROD, shift	1	X type

PWD

FIG. 12

FIG.12 ( C- 5) STARTING MOTOR (MODEL QD/VE)

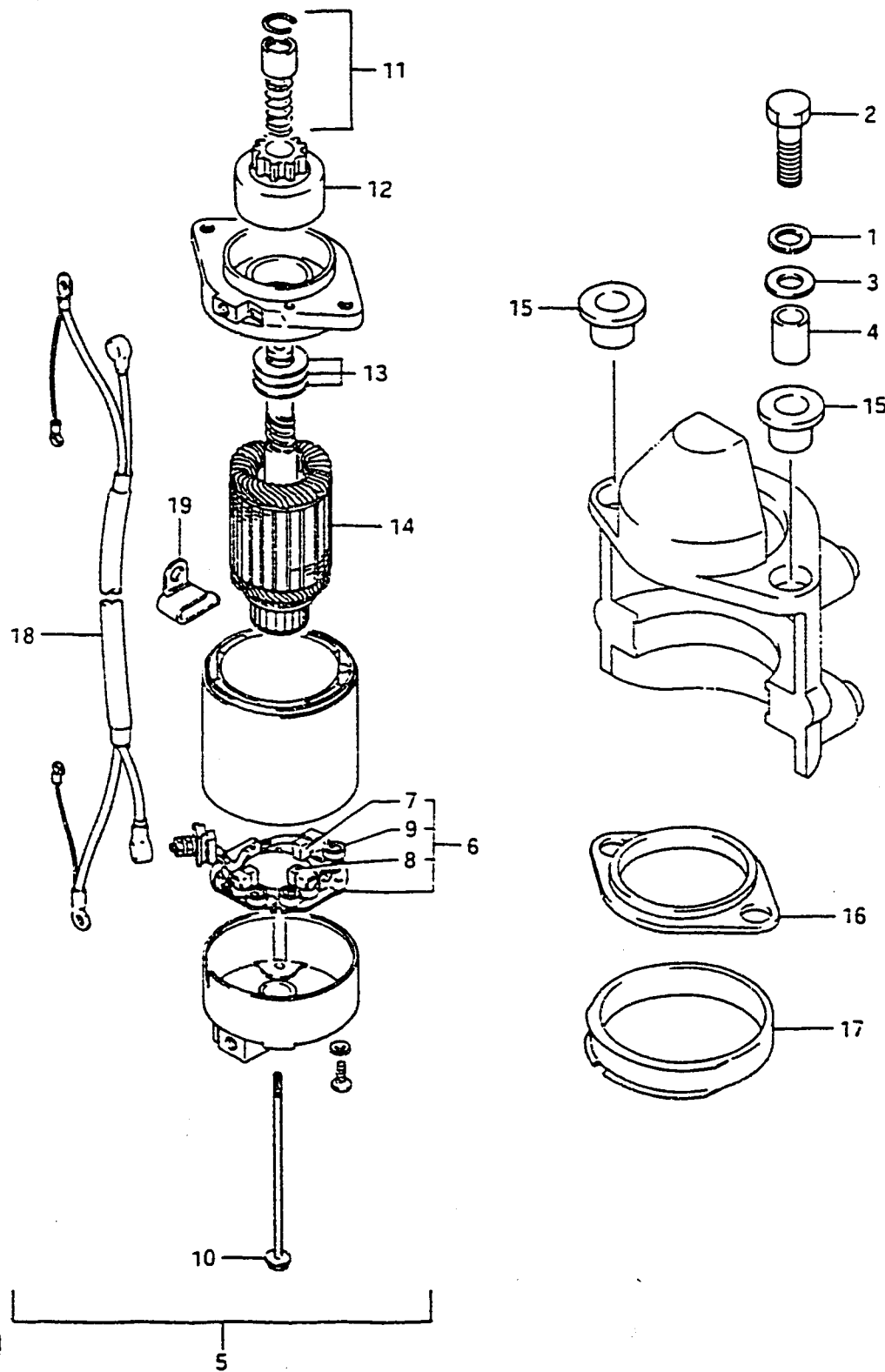


REF.NO.	PART NO.	DESCRIPTION	Q'TY	REMARKS
1	08321-21082	LOCK WASHER	2	
2	01107-08352	BOLT	2	
3	09160-08062	WASHER	2	
4	09180-08097	SPACER	2	
5	31100-94512	MOTOR ASSY, starting	1	
6	31173-94511	.HOLDER ASSY, motor brush	1	
7	31131-94510	..BRUSH (+)	2	
8	31132-94510	..BRUSH (-)	1	
9	31135-95240	..SPRING, brush	4	
10	31281-94510	.THROUGH BOLT	2	
11	31312-94500	.STOPPER SET, pinion	1	
12	31320-94510	.PINION ASSY	1	
13	31361-94510	.WASHER KIT	1	
14	31311-94511	.ARMATURE	1	
15	02112-04122	.SCREW	2	
16	31916-94500	DAMPER, upper	2	
17	31917-94500	DAMPER, middle	1	
18	31918-94500	DAMPER, lower	1	
19-1	33840-94511	CABLE, starter sub	1	model QD
19-2	33840-94520	CABLE, starter sub	1	model VE
20	33841-94501	CLAMP	1	
21	33850-94501	CABLE, grand	1	~303239
22	01107-08162	BOLT	1	
23	08321-21082	LOCK WASHER	1	

Refer to FIG.13 (C-6) for model VF

FIG. 13

FIG.13 ( C- 6) STARTING MOTOR (MODEL VF)

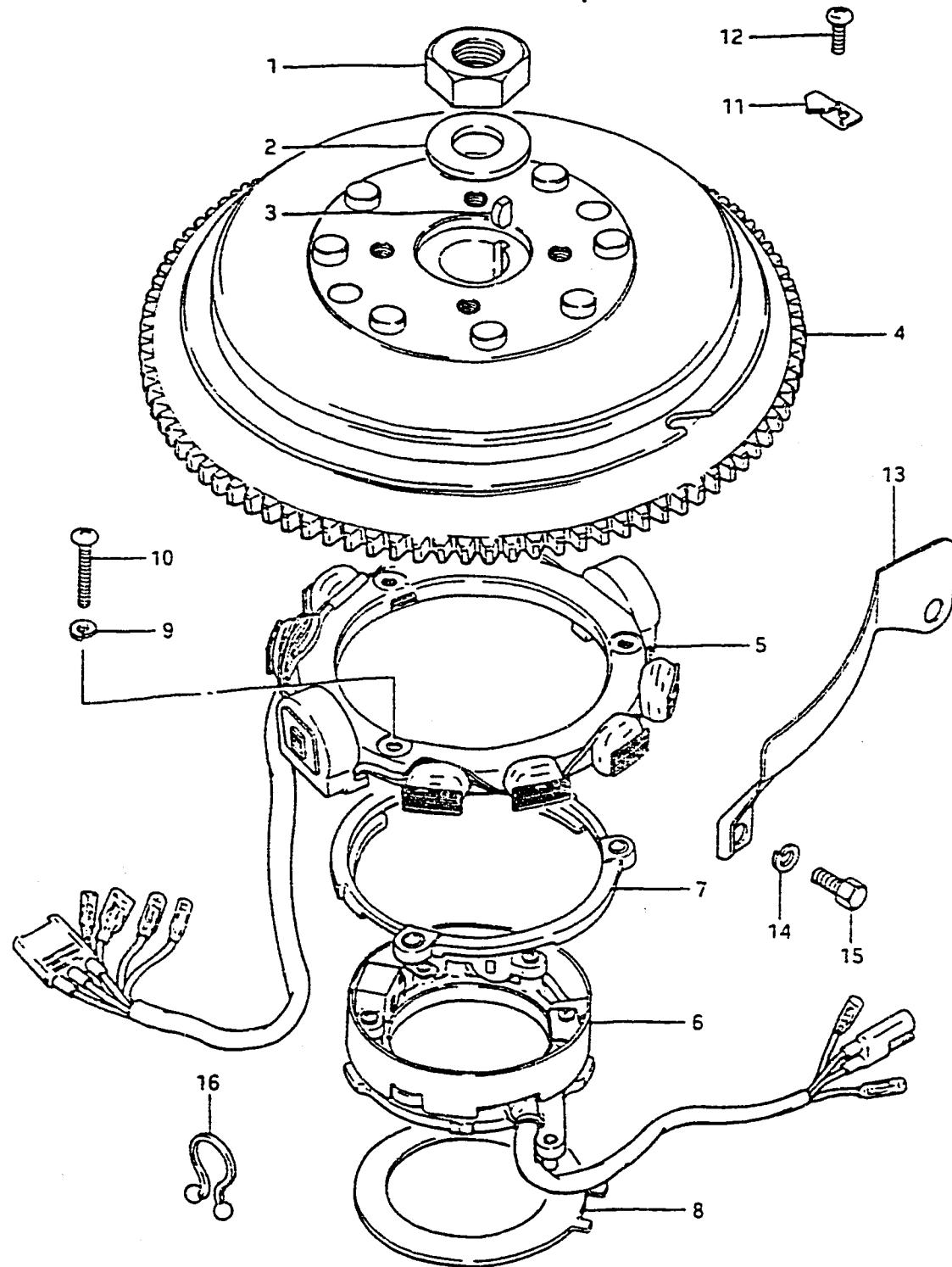


REF.NO.	PART NO.	DESCRIPTION	Q'TY	REMARKS
1	08321-21082	LOCK WASHER	2	
2	01107-08352	BOLT	2	
3	09160-08062	WASHER	2	
4	09180-08097	SPACER	2	
5	31100-94600	MOTOR ASSY, starting	1	
6	31173-95310	.HOLDER ASSY, motor brush	1	
7	31131-95310	..BRUSH (+)	2	
8	31132-95310	..BRUSH (-)	1	
9	31135-95310	..SPRING, brush	3	
10	31281-94510	..THROUGH BOLT	2	
11	31312-95241	..STOPPER SET, pinion	1	
12	31320-94510	..PINION ASSY	1	
13	31360-95520	..WASHER KIT	1	
14	31310-94600	..ARMATURE	1	
15	31916-94500	DAMPER, upper	2	
16	31917-94500	DAMPER, middle	1	
17	31918-94600	DAMPER, lower	1	
18	33840-94520	CABLE, starter sub	1	
19	33841-94501	CLAMP	1	

Refer to FIG.12 (C-5) for model QD/VE

FIG. 14

FIG.14 ( C- 7) MAGNETO



REF.NO.	PART NO.	DESCRIPTION	Q'TY	REMARKS
1	09140-18007	NUT	1	
2	09160-18011	WASHER (18.5x35x4)	1	
3	08341-31059	KEY	1	
4-1	32102-94503	FLYWHEEL	1	model QD/VE
4-2	32102-94510	FLYWHEEL	1	model VF
5	32101-94500	STATOR	1	
6-1	32160-94501	TIMER BASE & SENSOR ASSY	1	model QD/VE
6-2	32160-94510	TIMER BASE & SENSOR ASSY	1	model VF
7	32390-94501	RETAINER (2)	1	
8	32395-94502	RETAINER (1)	1	
9	08321-21067	LOCK WASHER	3	
10	02112-06302	SCREW	3	
11	32495-94500	TIMING POINTER	1	
12	02112-06102	SCREW	1	
13	11511-94504-02M	COVER, ring gear	1	
14	08321-21082	LOCK WASHER	2	
15	01107-08202	BOLT	2	
16	09408-00021	CLAMP	1	

FIG.15

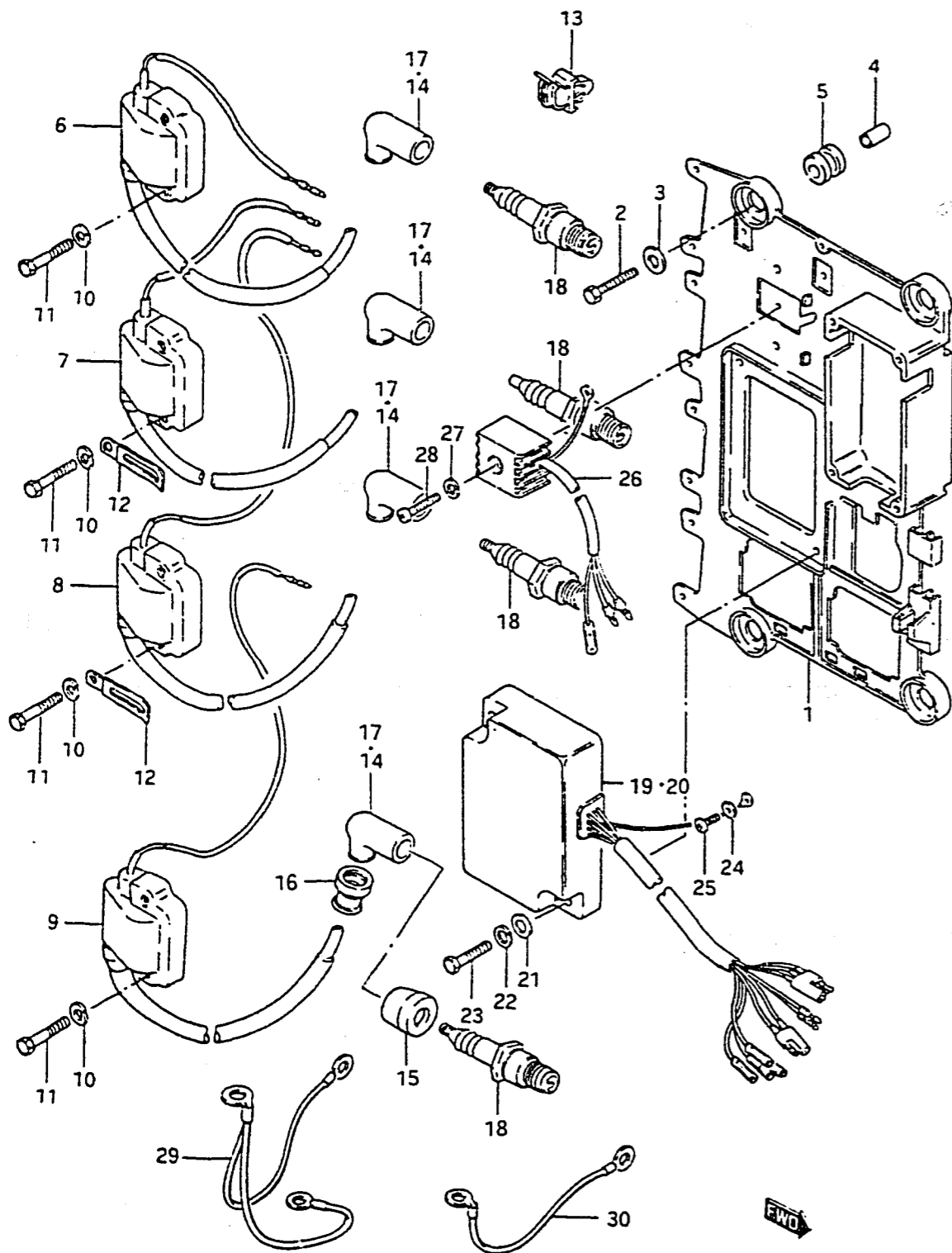
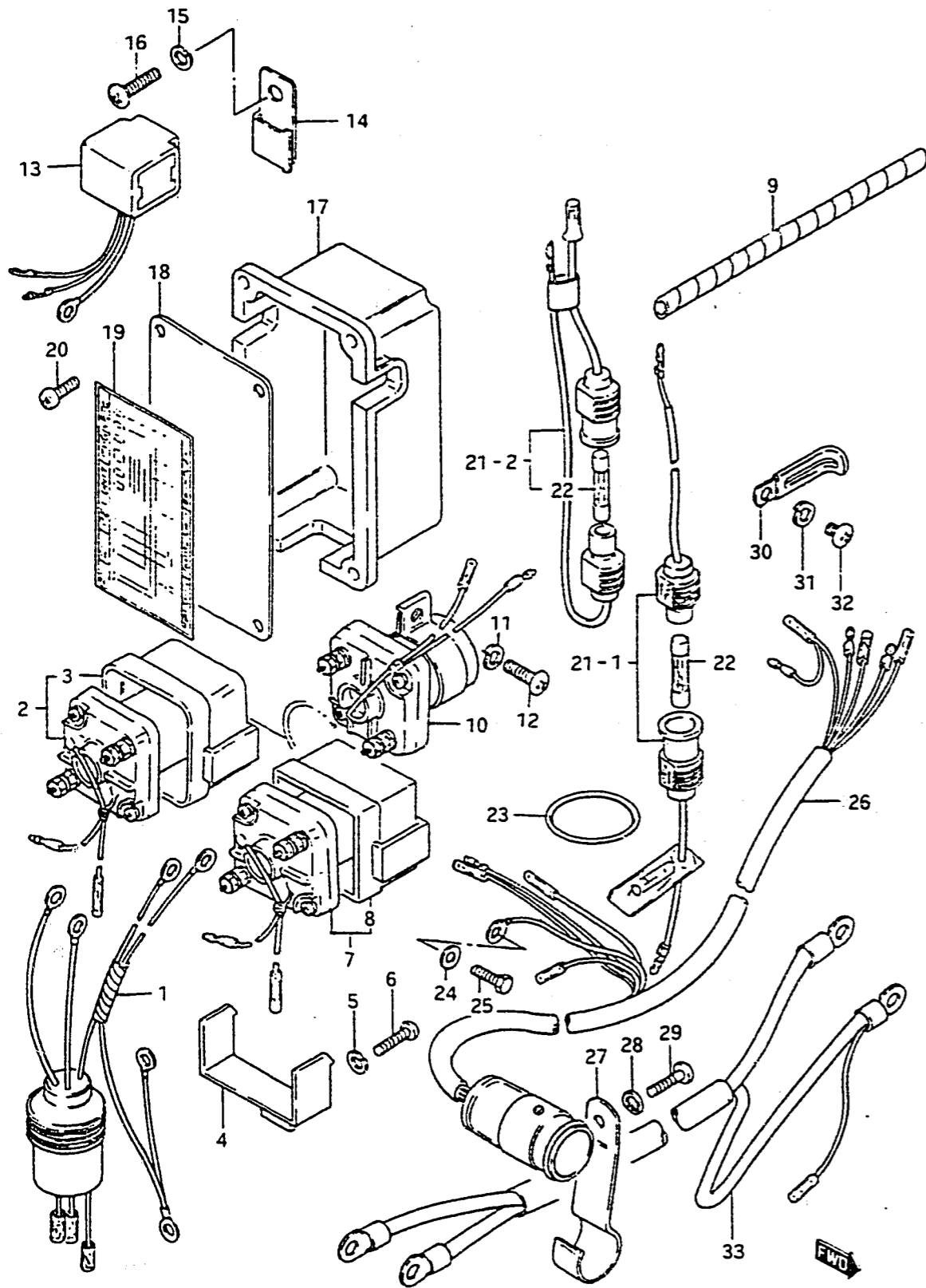


FIG.15 ( C- 8) IGNITION

REF.NO.	PART NO.	DESCRIPTION	Q'TY	REMARKS
1	32890-94500	HOLDER, electric parts	1	
2	01107-08302	BOLT	4	
3	09160-08054	WASHER (8.5x20x1.6)	4	
4	09180-08032	SPACER (8.2x12xY7)	4	
5	09320-12028	CUSHION	4	
6	33410-94500	COIL, ignition (1)	1	
7	33420-94500	COIL, ignition (2)	1	
8	33430-94500	COIL, ignition (3)	1	
9	33440-94500	COIL, ignition (4)	1	
10	08321-21062	LOCK WASHER	8	
11	01107-06302	BOLT	8	
12-1	09404-06401	CLAMP (L:50)	2	model QD
12-2	09404-06201	CLAMP (L:50)	2	model VE/VF
13	09403-07308	CLAMP	2	
14	33510-97313	CAP, spark plug	4	model QD
15	33541-93310	SEAL, spark plug	4	model QD
16	33542-98000	SEAL, high tension cord	4	model QD
17	33510-95510	CAP, spark plug	4	model VE/VF
18	09482-00151	SPARK PLUG (NGK,B8HS)	4	
19	32900-94501	C.D.I. UNIT	1	model QD/VE
20	32900-94510	C.D.I. UNIT	1	model VF
21	08322-21062	WASHER	2	
22	08321-21062	LOCK WASHER	2	
23	01107-06252	BOLT	2	
24	08321-21062	LOCK WASHER	1	
25	02112-06162	SCREW, earth	1	
26	32800-95720	RECTIFIER	1	
27	08321-21052	LOCK WASHER	1	
28	02112-05252	SCREW	1	
29	36895-95300	LEAD, engine ground	1	406188-
30	36895-94400	LEAD, engine ground	1	model VF

FIG. 16



DT115TC VF E3

FIG.16 ( C- 9) ELECTRICAL (1)

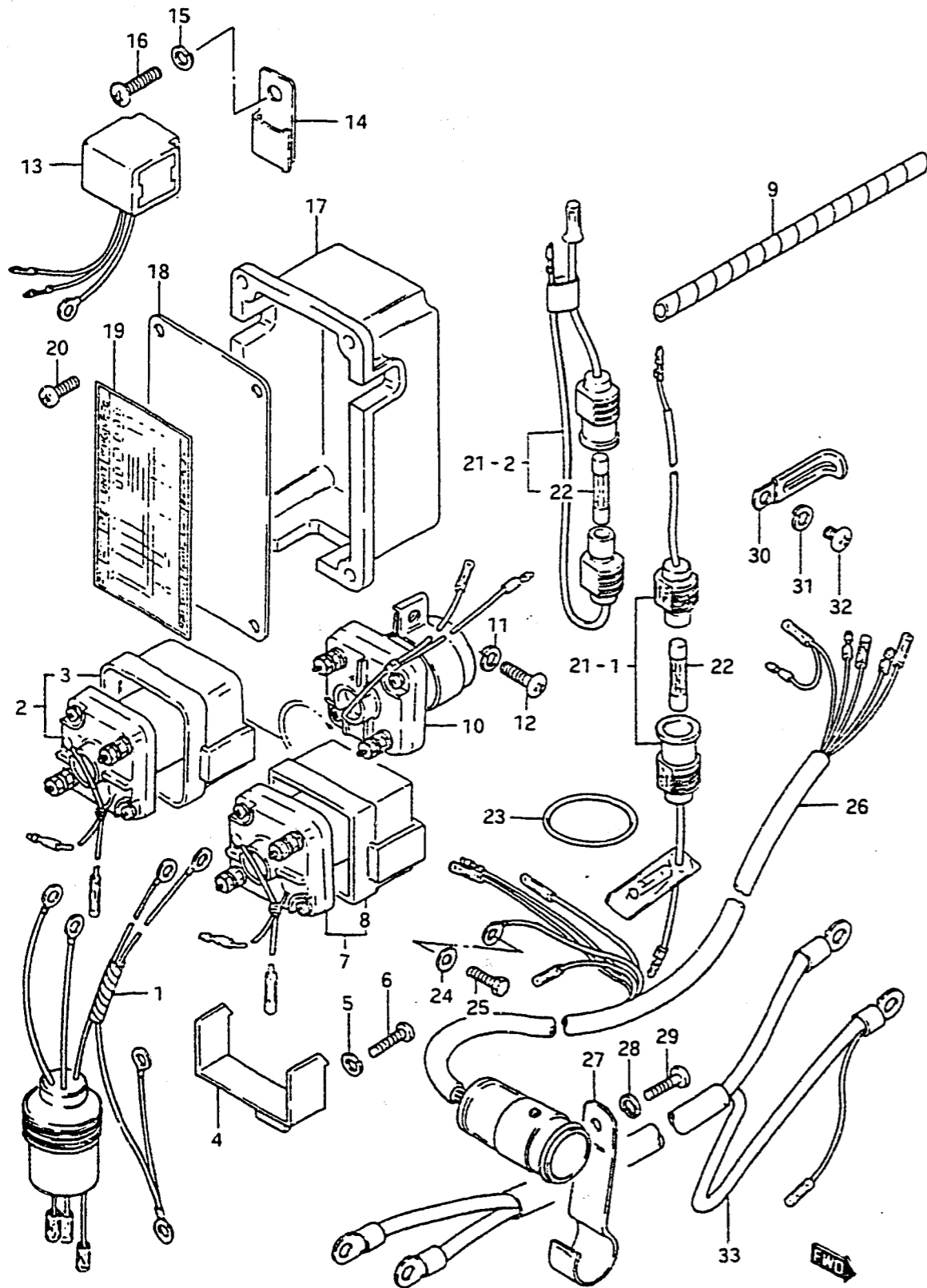
REF.NO.	PART NO.	DESCRIPTION	Q'TY	REMARKS
1	33830-94504	CABLE, trim relay in (L:300)	1	
2-1	38410-94510	TRIM RELAY, up	1	model QD
2-2	38410-94540	TRIM RELAY, up	1	model VE/VF
2-3	38410-94530	TRIM RELAY, up	1	OPT,with DAMPER
3	38422-94510	.DAMPER	1	OPT
4	38412-94500	BRACKET, trim relay	2	
5	08321-21067	LOCK WASHER	2	
6	02112-06168	SCREW	2	
7-1	38420-94520	TRIM RELAY, down	1	model QD
7-2	38420-94540	TRIM RELAY, down	1	model VE
7-3	38420-94530	TRIM RELAY, down	1	OPT,with DAMPER
8	38422-94510	.DAMPER	1	OPT
9-1	38423-95501	TUBE, trim relay lead	1	model QD
9-2	34863-94500	TUBE, 50	2	model VE/VF
10	31800-95522	RELAY, starter	1	
11	08321-21067	LOCK WASHER	1	
12	02112-06168	SCREW	1	
13	34861-94501	SEMICONDUCTOR, oil level	1	
14	34862-94500	BRACKET, semiconductor	1	
15	08321-21067	LOCK WASHER	1	
16	02112-06168	SCREW	1	
17	36653-94501	BOX, insulator	1	
18	36650-94500	COVER, junction box	1	
19	36652-94504	LABEL, diagram	1	
20	09125-05025	SCREW	4	
21-1	36740-95252	CASE, fuse	1	
21-2	36740-94500	CASE, fuse	1	
22	09481-20001	.FUSE (20A)	1	
23	09280-21013	O RING	2	model VE/VF

DT115TC VF E3

Revised March 1987



FIG.16



DT115TC VF E3

FIG.16 ( C-10) ELECTRICAL (1)

REF.NO.	PART NO.	DESCRIPTION	Q'TY	REMARKS
24	08327-21068	WASHER, earth lead	1	
25	01107-06128	BOLT, earth lead	1	
26	36610-94507	WIRING HARNESS	1	
27	36791-94502	HOLDER, wiring harness	1	
28	08321-21067	LOCK WASHER	1	
29	02112-06168	SCREW	1	
30-1	09404-06412	CLAMP (L:60)	1	model QD
30-2	09404-06202	CLAMP (L:60)	1	model VE/VF
31	08321-21067	LOCK WASHER	1	
32	02112-06088	SCREW	1	
33	33810-94502	CABLE, starter	1	

DT115TC VF E3

FIG.17

FIG.17 ( C-11) ELECTRICAL (2)

Q'TY

REF.NO.	PART NO.	DESCRIPTION	Q'TY	REMARKS
1	38600-94505	SOLENOID, choke	1	model QD
2	38601-94500	.SPACER (5.5x12x15.8)	1	
3	38600-94523	SOLENOID, choke	1	
4	38601-94500	.SPACER (5.5x12x15.8)	2	
5	08321-21057	LOCK WASHER	2	
6	08322-21057	WASHER	2	model VE/VF
7	01107-05307	BOLT	2	
8	09160-05010	WASHER	2	model VE/VF
9	01107-05127	BOLT	2	model VE/VF
10	08321-21057	LOCK WASHER	2	model VE/VF
11	08322-21057	WASHER	2	model VE/VF
12	34850-94552	SWITCH, heat	1	
13	34853-94500	SUPPORTER	1	
14-1	09404-10401	CLAMP (L:52)	1	model QD
14-2	09404-10201	CLAMP (L:52)	1	model VE/VF
15	34855-95550	GREASE, heat switch	1	OPT
16	09140-06020	NUT	1	
17	09160-06036	WASHER (6.5x18x1.5)	2	
18	33816-94500	CLAMP, cable	1	
19	09162-06001	LOCK WASHER	1	
20	09100-06112	BOLT (6x20)	1	
21-1	09404-08402	CLAMP	2	model QD
21-2	09404-08201	CLAMP	1	model VE/VF
22	33833-95500	TUBE, 100	1	model VE/VF

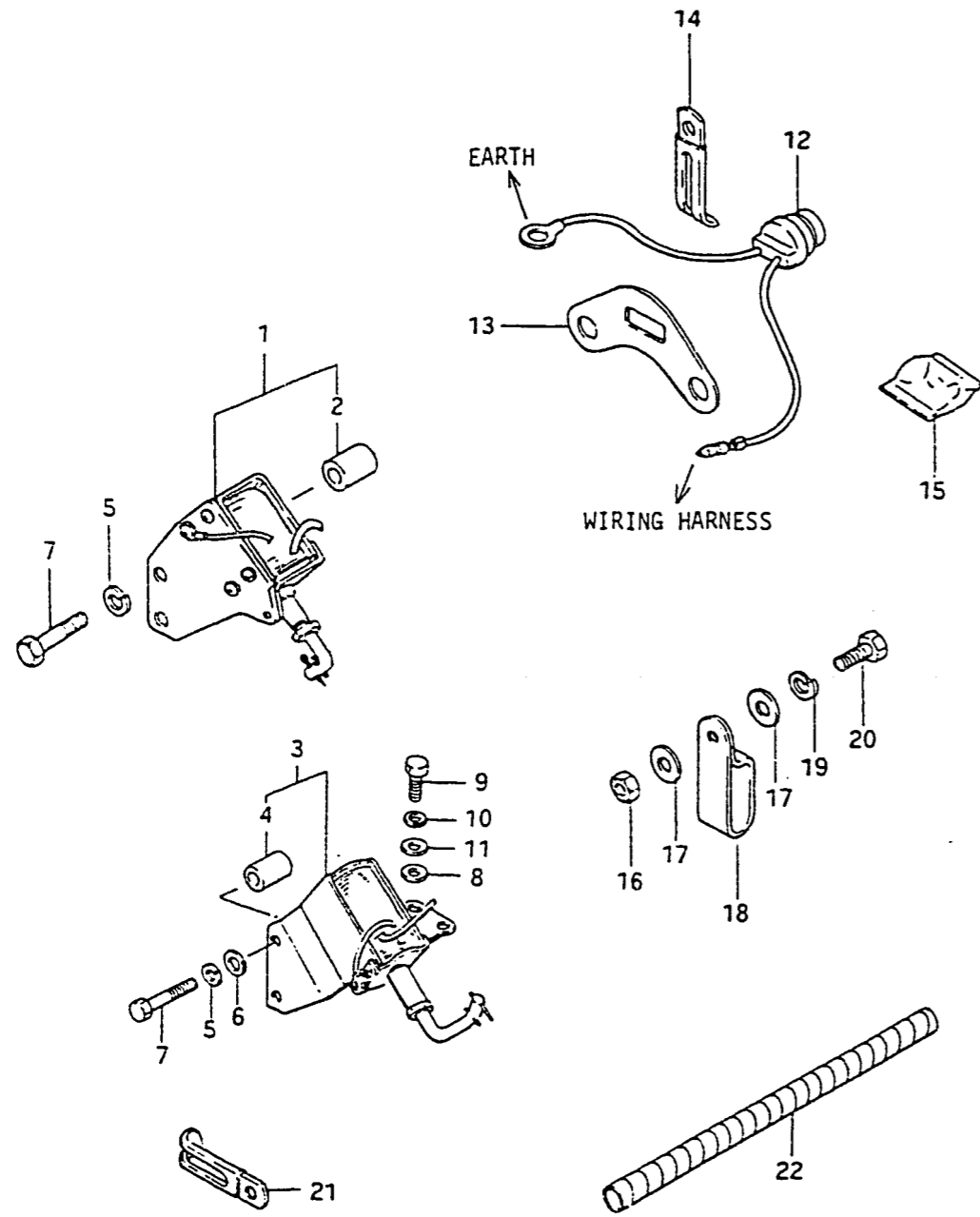


FIG. 18

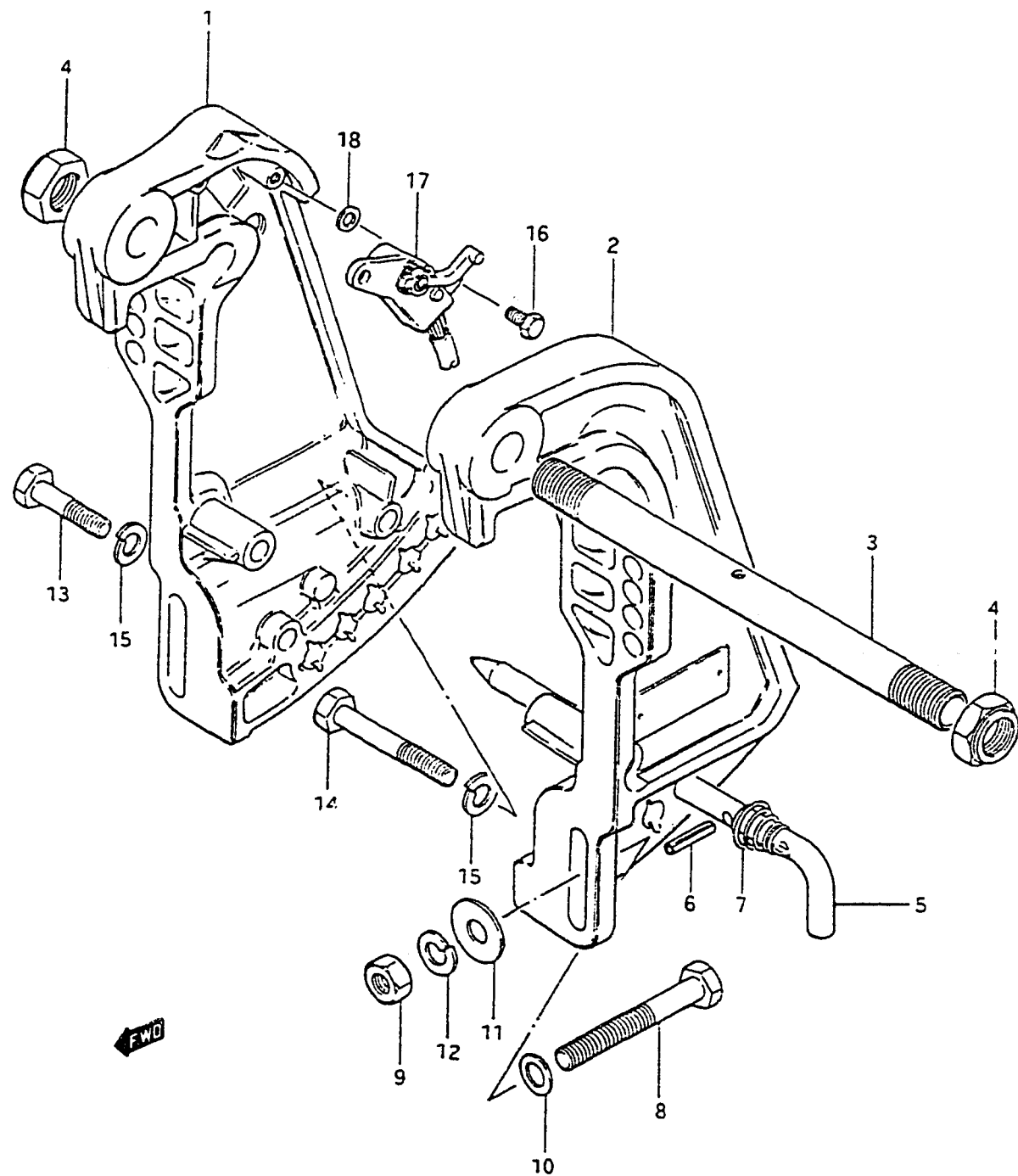


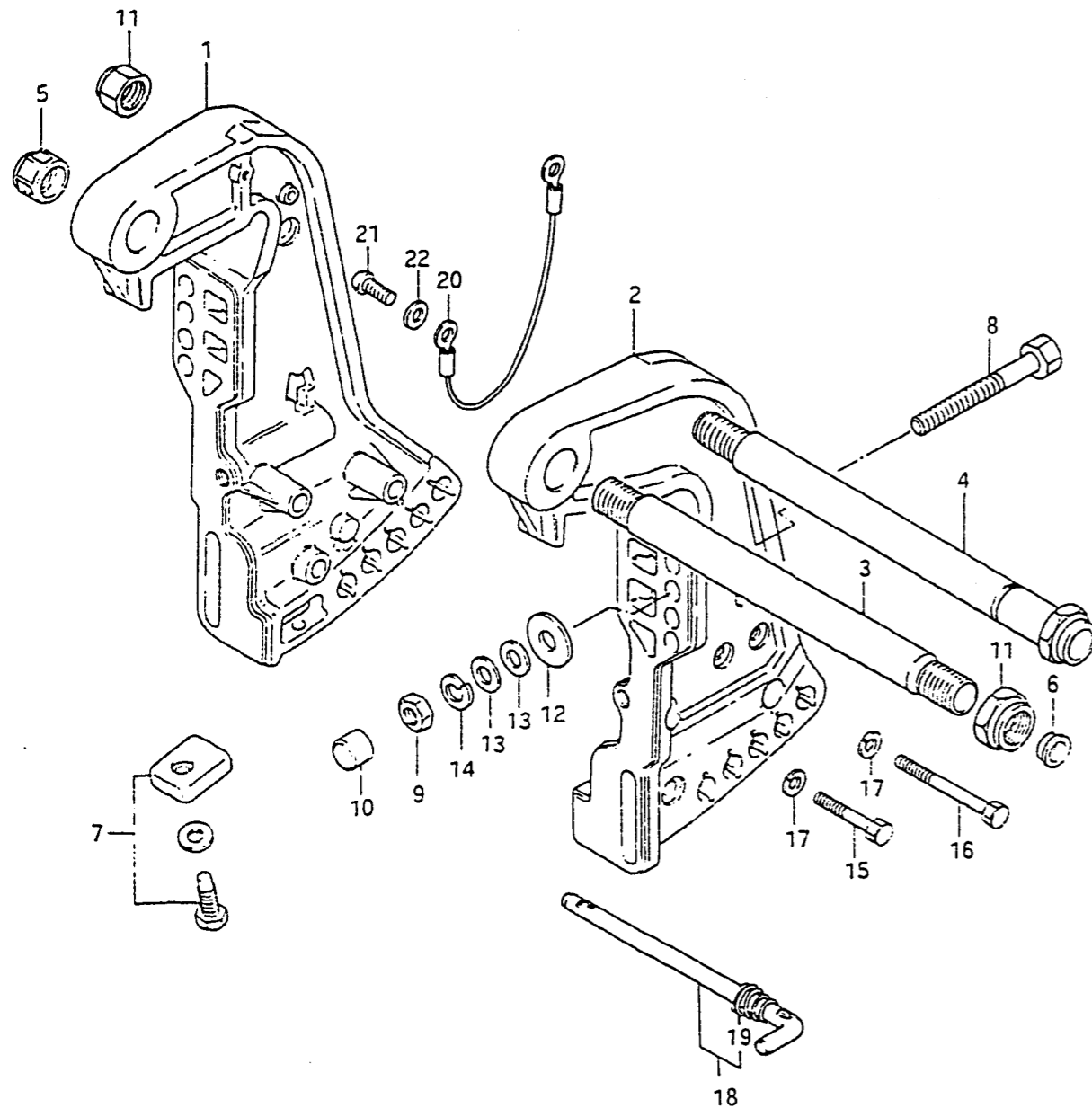
FIG.18 ( C-12) CLAMP BRACKET (MODEL QD)

REF.NO.	PART NO.	DESCRIPTION	Q'TY	REMARKS
1-1	41111-94502-02M	BRACKET, clamp, STBD	1	-304157
1-2	41111-94503-02M	BRACKET, clamp, STBD	1	304158-
2	41121-94502-02M	BRACKET, clamp, PORT	1	
3	41131-94500	SHAFT, clamp bracket	1	
4	09159-22002	NUT	2	
5	45421-94501	PIN, tilt lock	1	
6	09205-03017	SPRING PIN (3x20)	1	
7	09441-24002	SPRING (L:21)	1	
8	09100-12026	BOLT (12x100)	4	
9	09140-12029	NUT	4	
10	09160-12033	WASHER (12.5x22x2.5)	4	
11	09160-12044	WASHER (12.5x35x3.2)	4	
12	09162-12005	LOCK WASHER	4	
13	09100-10155	BOLT (10x50)	2	
14	09100-10156	BOLT	4	
15	09162-10005	LOCK WASHER	6	
16	09100-06019	BOLT (6x16)	2	
17	34801-94511	SENDER, trim	1	
18	09160-06015	WASHER	2	

Refer to FIG.19 (C-13) for model VE/VF

FIG. 19

FIG.19 ( C-13) CLAMP BRACKET (MODEL VE/VF)

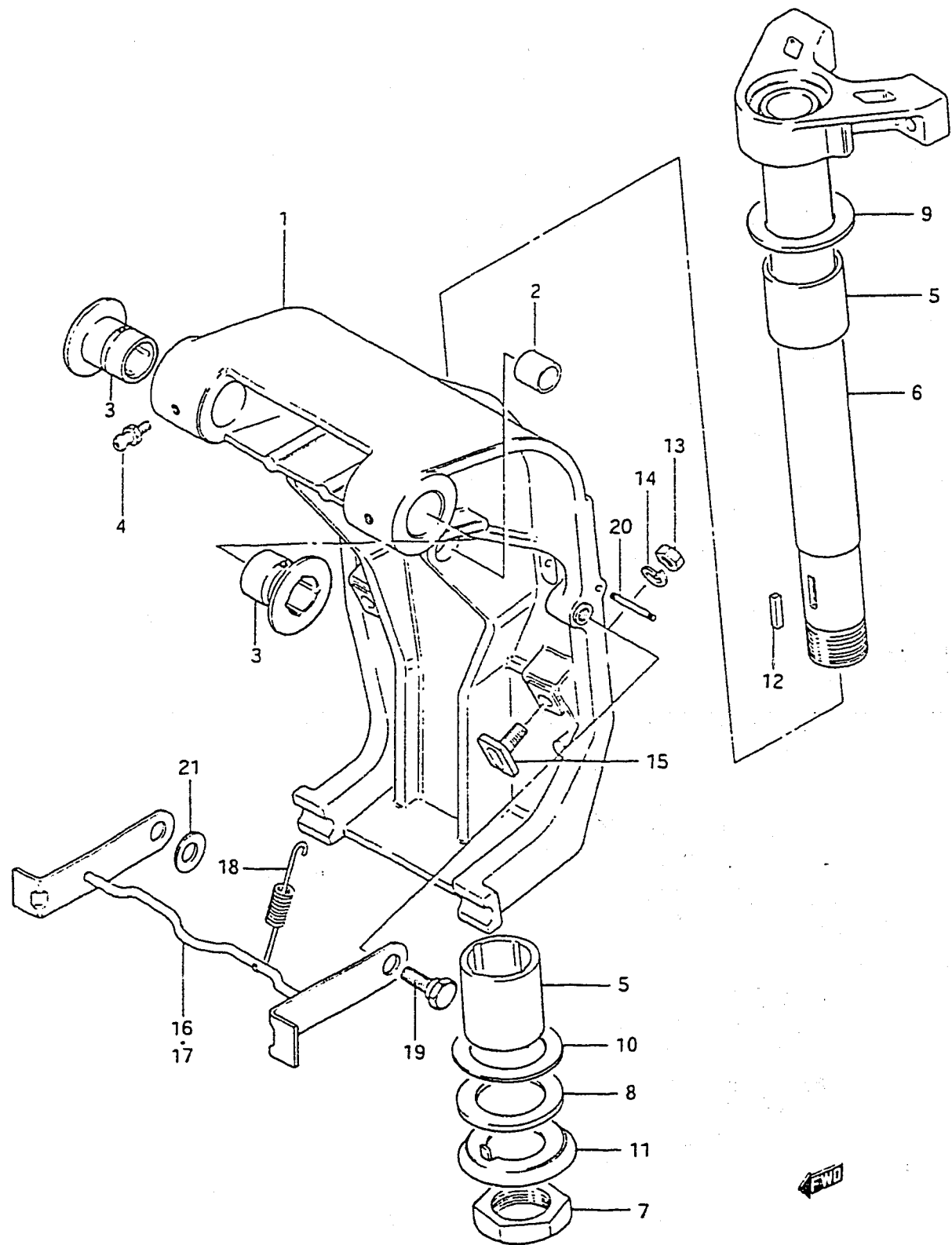


REF.NO.	PART NO.	DESCRIPTION	Q'TY	REMARKS
1-1	41111-94505-02M	BRACKET, clamp, STBD	1	model VE
1-2	41111-94510-02M	BRACKET, clamp, STBD	1	model VF
2-1	41121-94511-02M	BRACKET, clamp, PORT	1	model VE
2-2	41121-94530-02M	BRACKET, clamp, PORT	1	model VF
3	41131-94510	SHAFT, clamp bracket	1	model VE
4	41130-95510	SHAFT, clamp bracket	1	model VF
5	41151-94500	CAP, clamp bracket shaft	1	
6	41152-94500	PLUG, clamp bracket shaft	1	
7	55320-95310	ZINC SET, protection	1	
8	09100-12039	BOLT (12x100)	4	
9	09140-12028	NUT	4	
10	41153-94500	CAP	4	
11-1	09159-22003	NUT	2	model VE
11-2	09159-22003	NUT	1	model VF
12	09160-12044	WASHER	4	
13	09160-12066	WASHER	6	
14	09162-12005	WASHER	4	
15	09100-10155	BOLT (10x50)	2	
16	09100-10156	BOLT (10x80)	4	
17	09162-10005	WASHER	6	
18	45420-95500	PIN, tilt lock	1	
19	09441-24002	.SPRING	1	
20	36894-95200	LEAD (L:165)	2	
21	09125-05050	SCREW (5x8)	3	
22	09161-05014	WASHER (5.2x11x1)	3	

Refer to FIG.18 (C-12) for model QD

FIG. 20

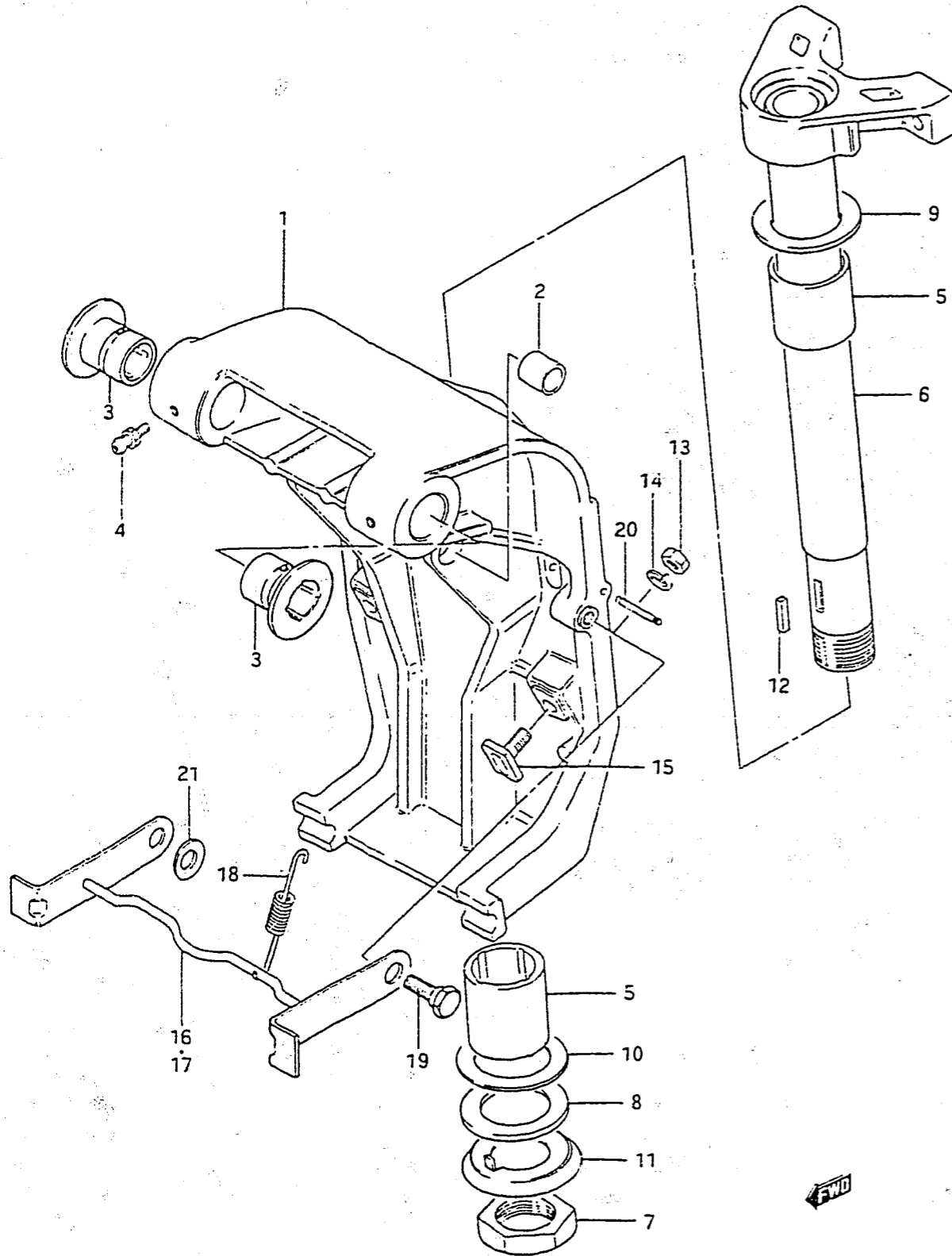
FIG. 20 ( C-14) SWIVEL BRACKET



REF.NO.	PART NO.	DESCRIPTION	Q'TY	REMARKS
1-1	43110-94500-02M	BRACKET, swivel	1	model QD
1-2	43111-94502-02M	BRACKET, swivel	1	404575-406187
1-3	43111-94503-02M	BRACKET, swivel	1	406188-406280
1-4	43111-94510-02M	BRACKET, swivel	1	model VF
2	09303-18001	.BUSHING	2	
3-1	09306-22002	BUSHING	2	model QD
3-2	43211-94500	BUSHING	2	model VE
3-3	43211-94510	BUSHING	2	model VF
4	22511-99001	GREASE NIPPLE	5	
5	09306-36002	BUSHING	2	
6	43740-94504-02M	SHAFT, pilot	1	
7	09140-33002	NUT	1	
8	09160-33002	WASHER, lower (33x60x3)	1	
9	09160-36004	WASHER, upper (36.5x60x2)	1	
10	09181-36006	SHIM (36.3x60x0.5)	0-2	
11	09166-33002	WASHER	1	
12	09421-05006	KEY	1	
13	09140-08016	NUT, trim cylinder ram	2	
14	09162-08007	LOCK WASHER	2	
15	48311-94501	PAD, trim cylinder ram	2	

FIG. 20

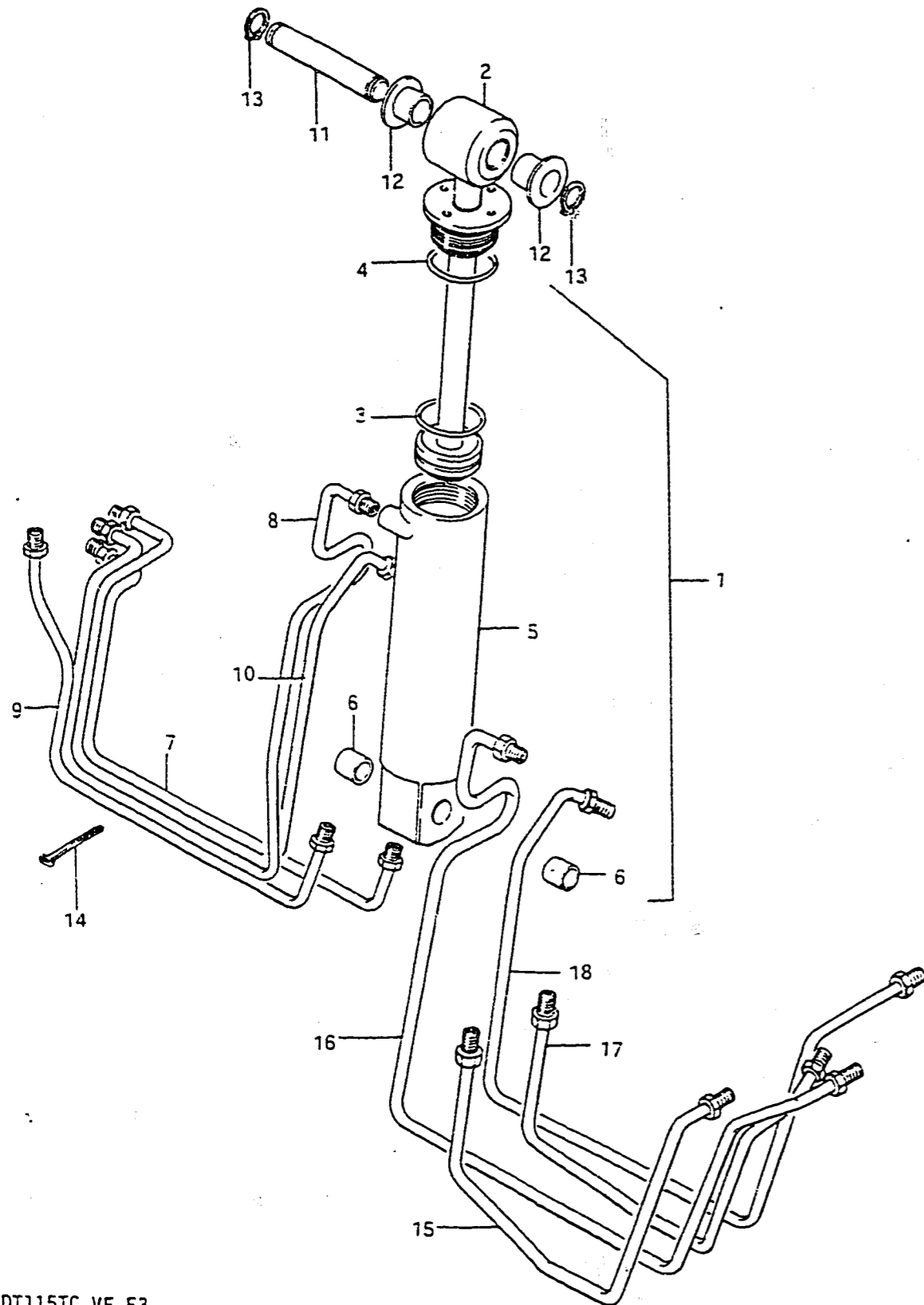
FIG. 20 ( C-15) SWIVEL BRACKET



REF.NO.	PART NO.	DESCRIPTION	Q'TY	REMARKS
16	41220-94502-02M	LEVER, tilt lock	1	model QD
17-1	41220-95500	LEVER, tilt lock	1	model VE
17-2	41220-95501-02M	LEVER, tilt lock	1	model VF
18-1	09443-10021	SPRING (L:86)	1	model QD
18-2	09443-10029	SPRING (L:81)	1	model VE/VF
19	09111-12008	BOLT	2	
20-1	41225-94500	PIN, tilt lock spring	1	model QD
20-2	41225-94501	PIN, tilt lock spring	1	model VE/VF
21	09160-10040	WASHER	1	

FIG. 21

FIG. 21 ( D- 2) TILT CYLINDER



REF.NO.	PART NO.	DESCRIPTION	Q'TY	REMARKS
1	48400-94500-02 <sup>M</sup>	1 TILT CYLINDER ASSY	1	
2	48401-94500	.PISTON & PISTON ROD SUB ASSY	1	
3	48427-94500	.O RING, piston	1	
4	48433-94500	.O RING	1	
5	48441-94500	.TUBE, cylinder	1	
6	09303-18001	.BUSHING	2	
7-1	48720-94520	PIPE, tilt inlet	1	model QD
7-2	48720-94521	PIPE, tilt inlet	1	model VE/VF
8-1	48730-94520	PIPE, tilt outlet	1	model QD
8-2	48730-94521	PIPE, tilt outlet	1	model VE/VF
9-1	48740-94520	PIPE, trim inlet	1	model QD
9-2	48740-94521	PIPE, trim inlet	1	model VE/VF
10-1	48750-94520	PIPE, trim outlet	1	model QD
10-2	48750-94521	PIPE, trim outlet	1	model VE/VF
11	48321-94510	SHAFT, tilt cylinder upper	1	
12	09306-16003	BUSHING	2	
13	09380-16003	SNAP RING	2	
14	36632-95501	CLAMP, PTT pipe	6	
15	48720-94580	TUBE, tilt inlet	1	OPT:PORT SIDE
16	48730-94580	TUBE, tilt outlet	1	OPT:PORT SIDE
17	48740-94580	TUBE, trim inlet	1	OPT:PORT SIDE
18	48740-94580	TUBE, trim outlet	1	OPT:PORT SIDE

FIG. 22

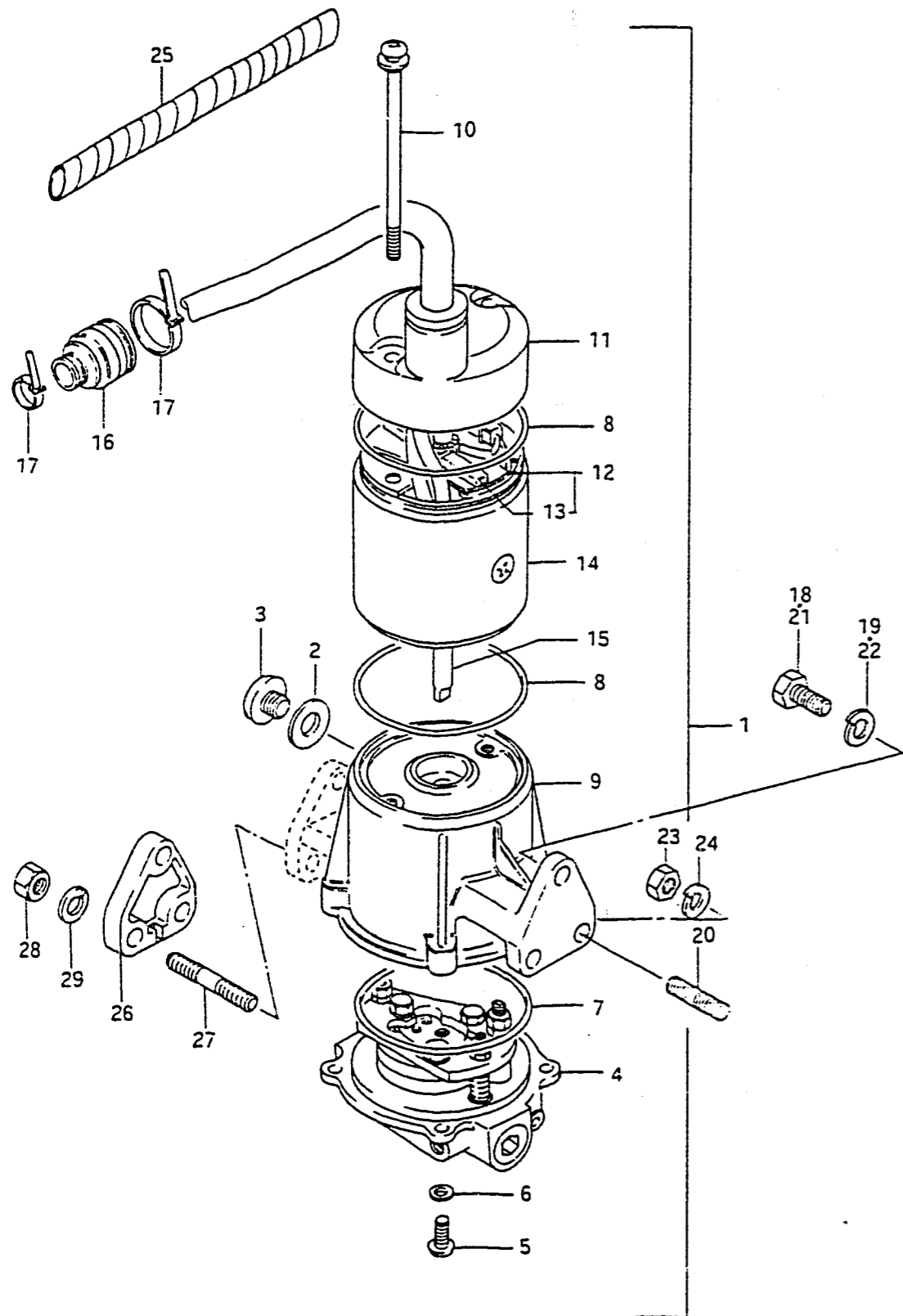


FIG. 22 ( D- 3) POWER UNIT

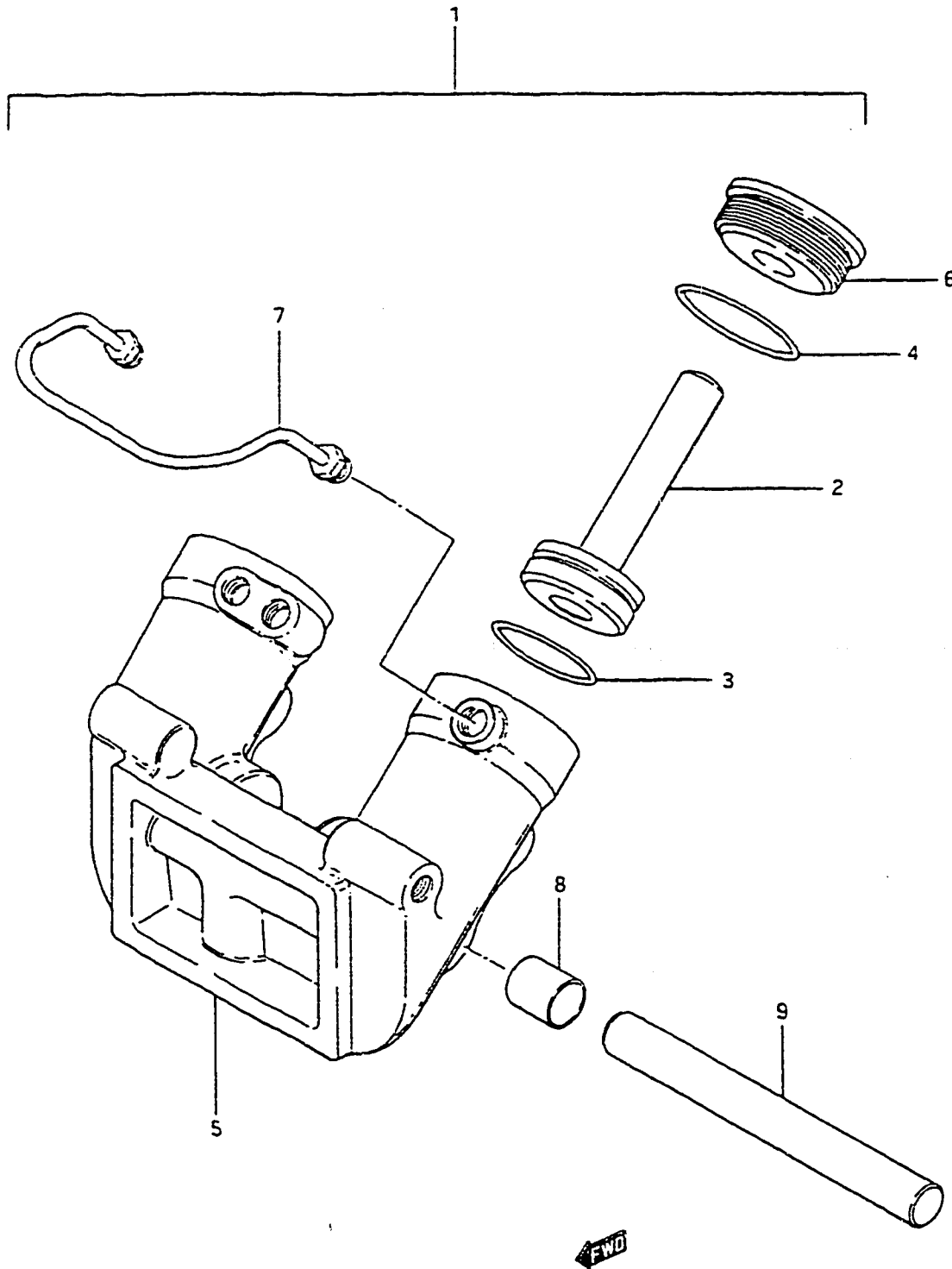
Q'TY

REF.NO.	PART NO.	DESCRIPTION	Q'TY	REMARKS
1-1	48500-94520-02M	POWER UNIT ASSY, power trim	1	model QD
1-2	48500-94521-02M	POWER UNIT ASSY, power trim	1	model VE
1-3	48500-94523-02M	POWER UNIT ASSY, power trim	1	406057~
1-4	48500-94581-02M	POWER UNIT ASSY, power trim	1	OPT:PORT SIDE
2	09168-10022	.GASKET	1	
3	09248-10005	.PLUG	1	
4-1	48502-94520	.VALVE BODY	1	model QD/VE
4-2	48502-94522	.VALVE BODY	1	model VF
5	09125-05048	.SCREW	4	
6-1	09160-05010	.WASHER	4	model QD
6-2	09160-05032	.WASHER	4	model VE/VF
7	48585-94520	.O RING	1	
8	09280-70006	.O RING	2	
9	48570-94521-02M	.RESERVOIR ASSY	1	
10	31281-94520	.SCREW	2	
11	31170-94520-02M	.COVER, upper	1	Harness not included
12	31173-94520	.BRUSH HOLDER ASSY	1	
13	31133-94520	.BRUSH	2	
14	31110-94520-02M	.YOKE ASSY	1	
15	31311-94520	.ARMATURE	1	
16	33899-95500	.SEAL, PTT cable	1	
17	36632-95501	.CLAMP	2	
18	09100-08154	BOLT	3	model QD
19	09162-08007	LOCK WASHER	3	model QD
20	09108-08130	STUD BOLT (8x20)	2	model VE/VF
21	09100-08219	BOLT	1	model VE/VF
22	09162-08007	LOCK WASHER	1	model VE/VF
23	09140-08016	NUT	2	model VE/VF
24	09162-08007	LOCK WASHER	2	model VE/VF
25	38423-95501	TUBE PTT motor cable	1	model QD
26	48131-95200	SPACER	1	OPT:PORT SIDE
27	09108-08137	BOLT (8x35)	3	OPT:PORT SIDE
28	09140-08016	NUT	3	OPT:PORT SIDE
29	09162-08007	LOCK WASHER	3	OPT:PORT SIDE



**FIG. 23**

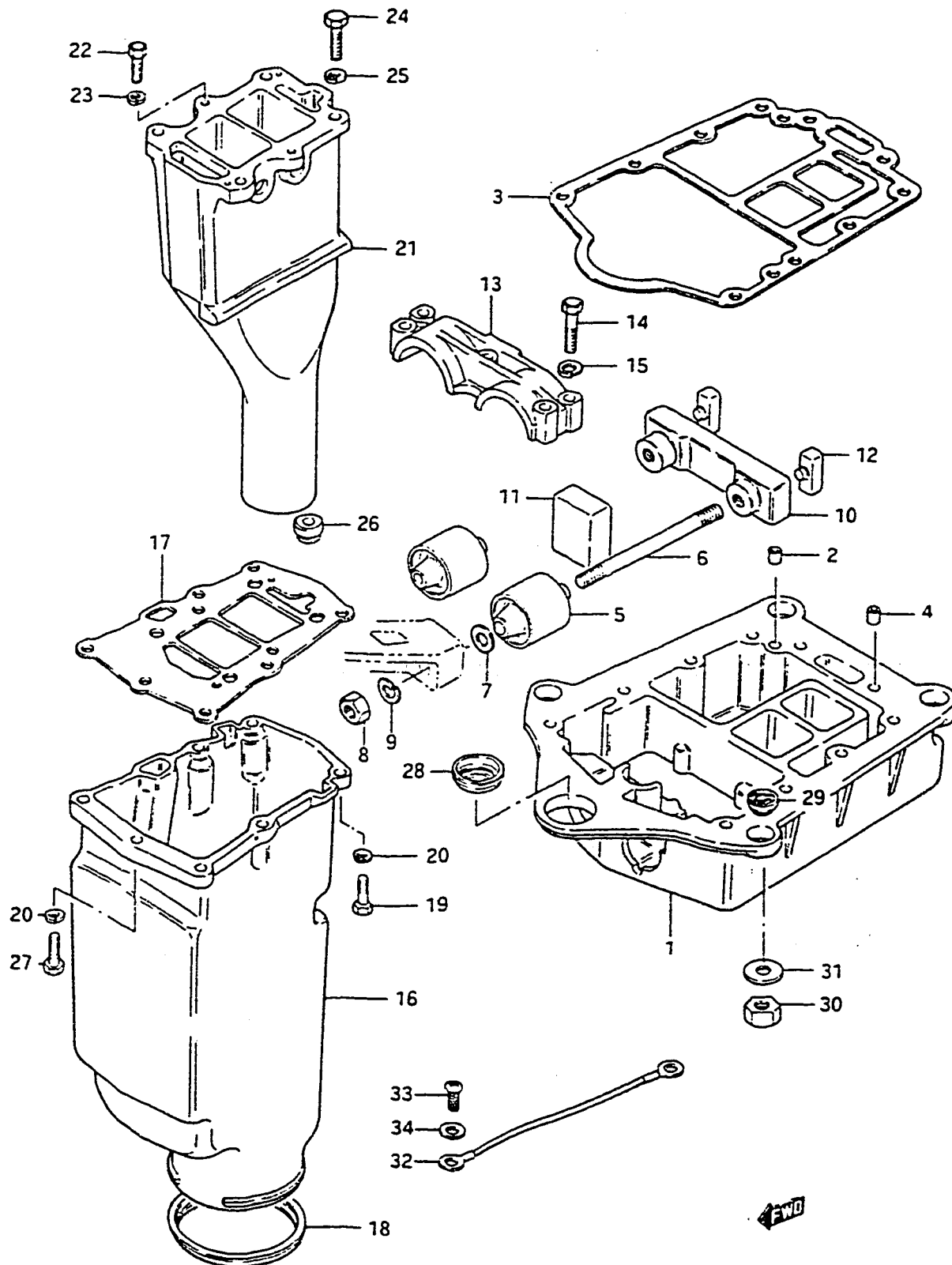
**FIG. 23 ( D- 4) TRIM CYLINDER**



REF.NO.	PART NO.	DESCRIPTION	Q'TY	REMARKS
1	48600-94500-02M	TRIM CYLINDER ASSY	1	
2-1	48601-94500	.PISTON & PISTON ROD ASSY	2	model QD/VE
2-2	48601-94501	.PISTON & PISTON ROD ASSY	2	model VF
3	48627-94500	.O RING, piston	4	
4	48633-94500	.O RING, head	4	
5	48641-94500	.CYLINDER, trim	1	
6	48630-94500	.HEAD, trim cylinder	2	
7-1	48760-94500	.TUBE, trim cylinder outlet	1	model QD
7-2	48760-94501	.TUBE, trim cylinder outlet	1	model VE/VF
8	09303-18001	.BUSHING	4	
9	48121-94510	SHAFT, tilt cylinder lower	1	

FIG. 24

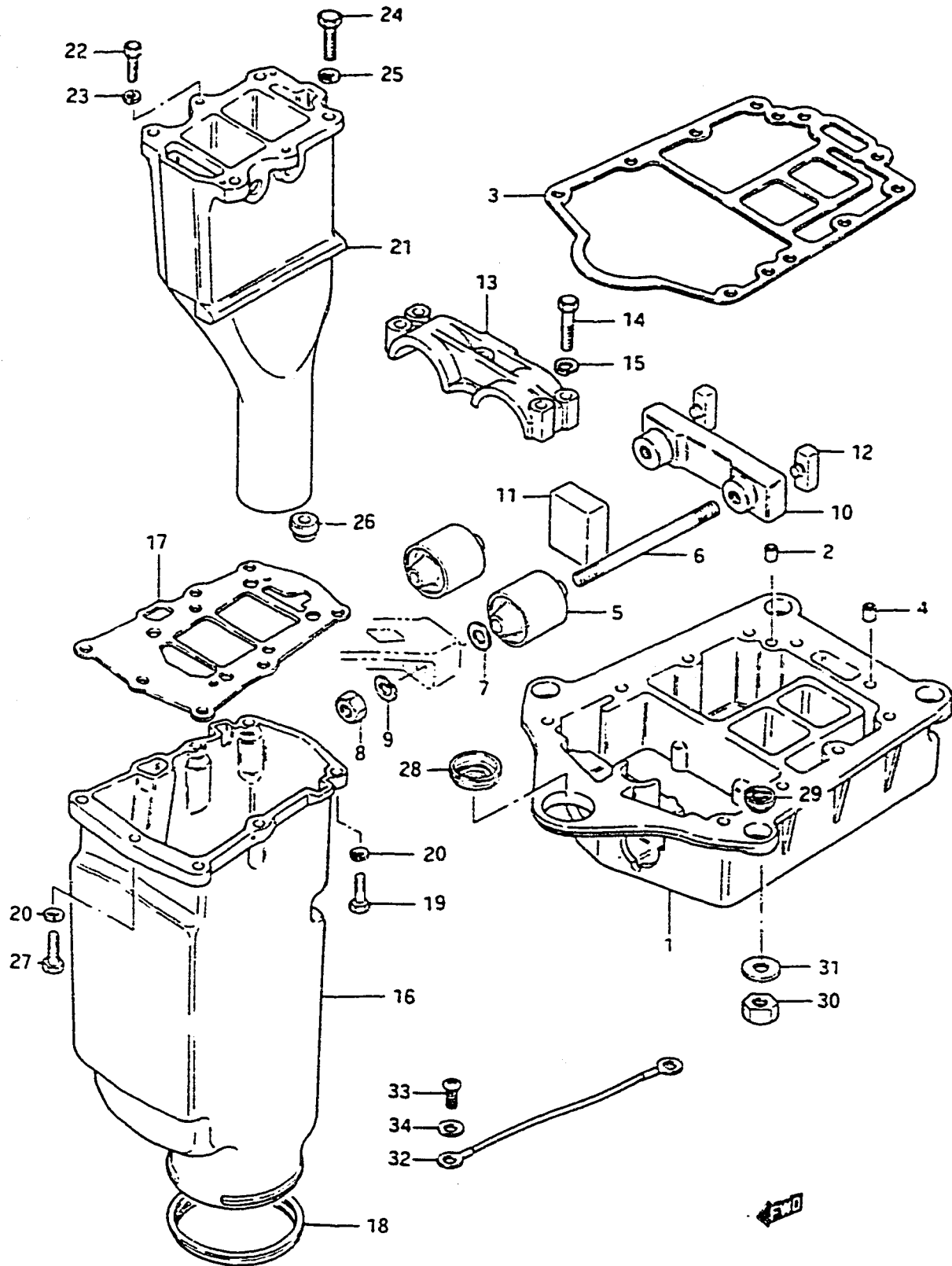
FIG. 24 ( D- 5) ENGINE HOLDER



REF.NO.	PART NO.	DESCRIPTION	Q'TY	REMARKS
1-1	51111-94503-02M	HOLDER, engine	1	model QD
1-2	51111-94505-02M	HOLDER, engine	1	404575-405904
1-3	51111-94507-02M	HOLDER, engine	1	405905-
2	09206-11001	PIN (11x12)	2	
3	51211-94501	GASKET, engine holder	1	
4	09206-13006	PIN (13x20)	2	
5-1	54130-94500	MOUNTING, upper	2	
5-2	54130-94510	MOUNTING, upper	2	OPT:HARD TYPE
6	09108-12002	STUD BOLT	2	
7	09160-12067	SHIM	1-2	
8	09140-12029	NUT	2	
9	09162-12005	LOCK WASHER	2	
10	54136-94503	STOPPER, upper mounting	1	
11-1	54141-94501	MOUNTING, upper front	1	
11-2	54141-94510	MOUNTING, upper front	1	OPT:HARD TYPE
12-1	54142-94502	MOUNTING, upper rear	2	
12-2	54142-94510	MOUNTING, upper rear	2	OPT:HARD TYPE
13	51112-94502	COVER, upper mounting	1	
14	09100-08160	BOLT (8x45)	5	
15	09162-08007	LOCK WASHER	5	
16	52171-94503	HOUSING, exhaust	1	
17	52172-94503	GASKET, exhaust housing	1	
18	52173-94502	SEAL, exhaust housing	1	
19	09100-06039	BOLT	6	
20	09162-06001	LOCK WASHER	7	

FIG. 24

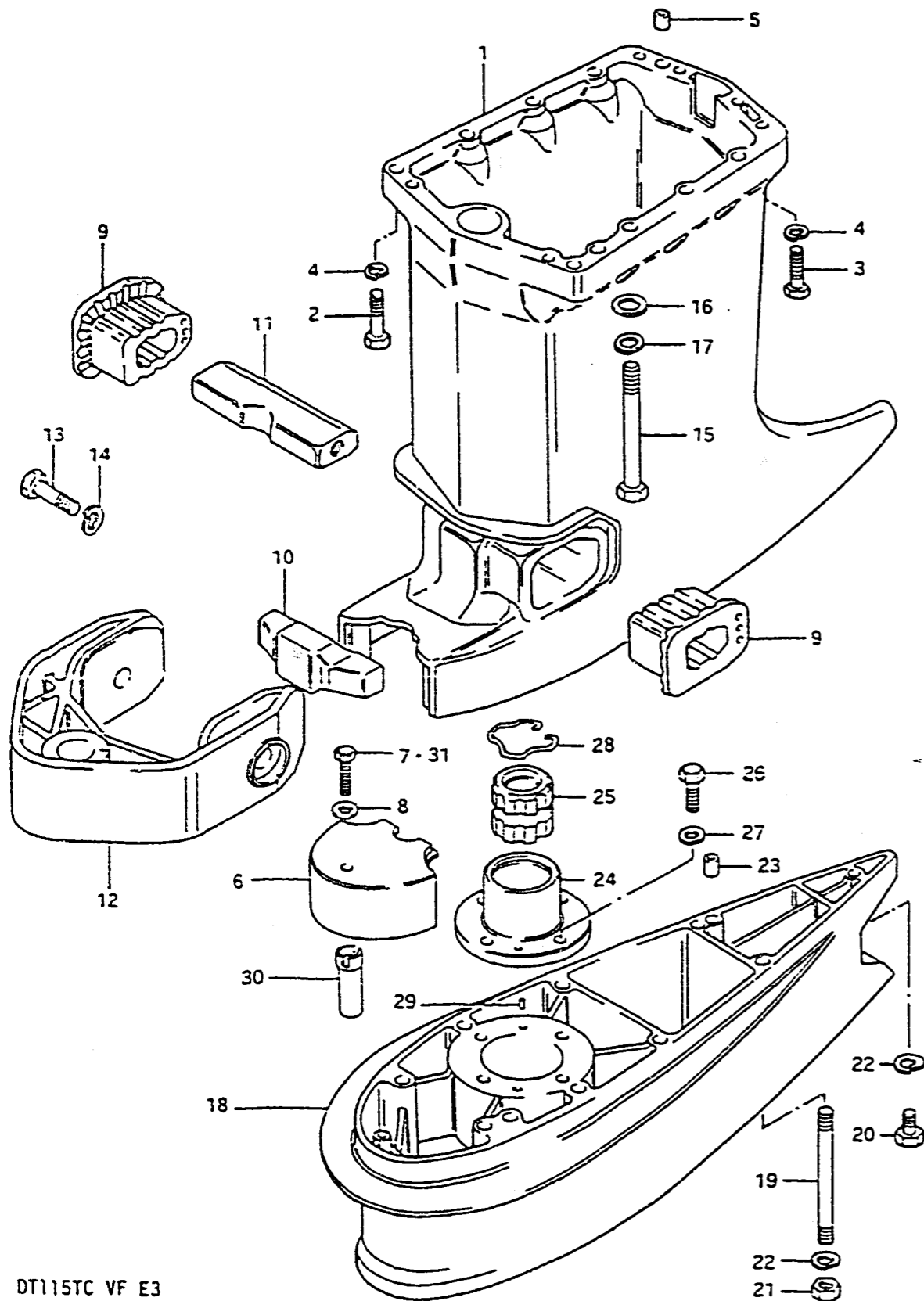
FIG. 24 ( D- 6) ENGINE HOLDER



REF.NO.	PART NO.	DESCRIPTION	Q'TY	REMARKS
21-1	14211-94505	TUBE, exhaust	1	-404622
21-2	14211-94506	TUBE, exhaust	1	404623-406280
21-3	14211-94511	TUBE, exhaust	1	506281-
22	09100-06089	BOLT	2	
23	09162-06001	LOCK WASHER	2	
24	09100-08232	BOLT (8x30)	4	
25	09162-08007	LOCK WASHER	4	
26	09308-06010	GROMMET	1	
27	09100-06121	BOLT	1	
28	09284-08004	SEAL	1	
29	09319-08019	BUSHING	4	
30	09140-08016	NUT	4	
31	09160-08081	WASHER	4	
32	36894-95200	LEAD (L:165)	1	
33	09125-05050	SCREW (5x8)	2	
34	09161-05014	WASHER (5.2x11x1)	2	

FIG. 25

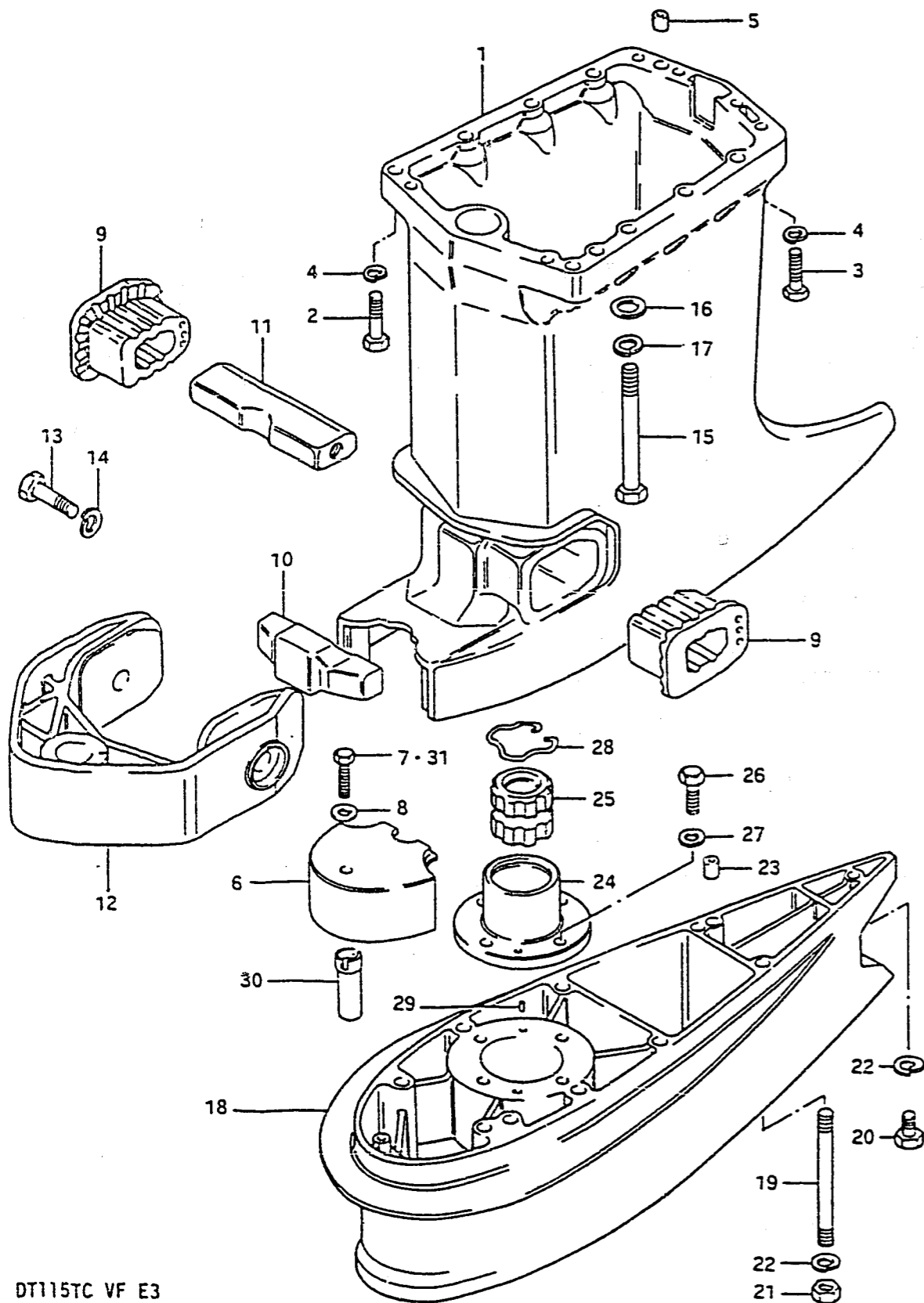
FIG.25 ( D- 7) DRIVESHAFT HOUSING



REF.NO.	PART NO.	DESCRIPTION	Q'TY	REMARKS
1-1	52111-94506-02M	HOUSING, drive shaft	1	-405973
1-2	52111-94507-02M	HOUSING, drive shaft	1	405974-406280
1-3	52111-94508-02M	HOUSING, drive shaft	1	506281-
2	09100-08220	BOLT (8x40)	2	
3	09100-08224	BOLT (8x35)	4	
4	09162-08007	LOCK WASHER	6	
5	09206-11001	PIN	2	
6	52121-94502-02M	COVER, drive shaft housing	1	
7-1	09100-06022	BOLT (6x35)	1	model QD
7-2	09100-06117	BOLT (6x35)	1	model VE
7-3	09100-06029	BOLT (6x40)	1	model VF
8	09160-06082	WASHER (6.5x13x1)	1	
9-1	54161-94503	MOUNTING, lower	2	
9-2	54161-94510	MOUNTING, lower	2	OPT:HARD TYPE
10-1	54165-94504	MOUNTING, lower thrust	1	
10-2	54165-94510	MOUNTING, lower thrust	1	OPT:HARD TYPE
11	54166-94501	STOPPER, lower mounting	1	
12-1	54210-94501-02M	BRACKET, lower mounting	1	model QD/VE
12-2	54210-94503-02M	BRACKET, lower mounting	1	model VF
13	09104-14001	BOLT (14x55)	2	
14	09162-14004	LOCK WASHER	2	
15	09100-10159	BOLT (10x130)	8	
16	09162-10005	LOCK WASHER	8	
17	09160-10040	WASHER	8	

FIG. 25

FIG. 25 ( D- 8) DRIVESHAFT HOUSING



REF.NO.	PART NO.	DESCRIPTION	Q'TY	REMARKS
18	52131-94502-02M	CASE, extension	1	X TYPE
19	09108-10050	STUD BOLT	8	
20	09100-10157	BOLT	1	
21	09140-10031	NUT	8	
22	09162-10005	LOCK WASHER	9	
23	09206-11001	PIN	2	
24	52161-94500	HOUSING, bushing	1	
25	57130-94500	BUSHING, driveshaft	1	
26	09100-08232	BOLT	4	
27	09162-08007	LOCK WASHER	4	
28	09387-45001	RING	1	
29	04221-05109	PIN	2	
30	52122-94500	SPACER, cover	1	
31	09100-06118	BOLT	1	

FIG. 26

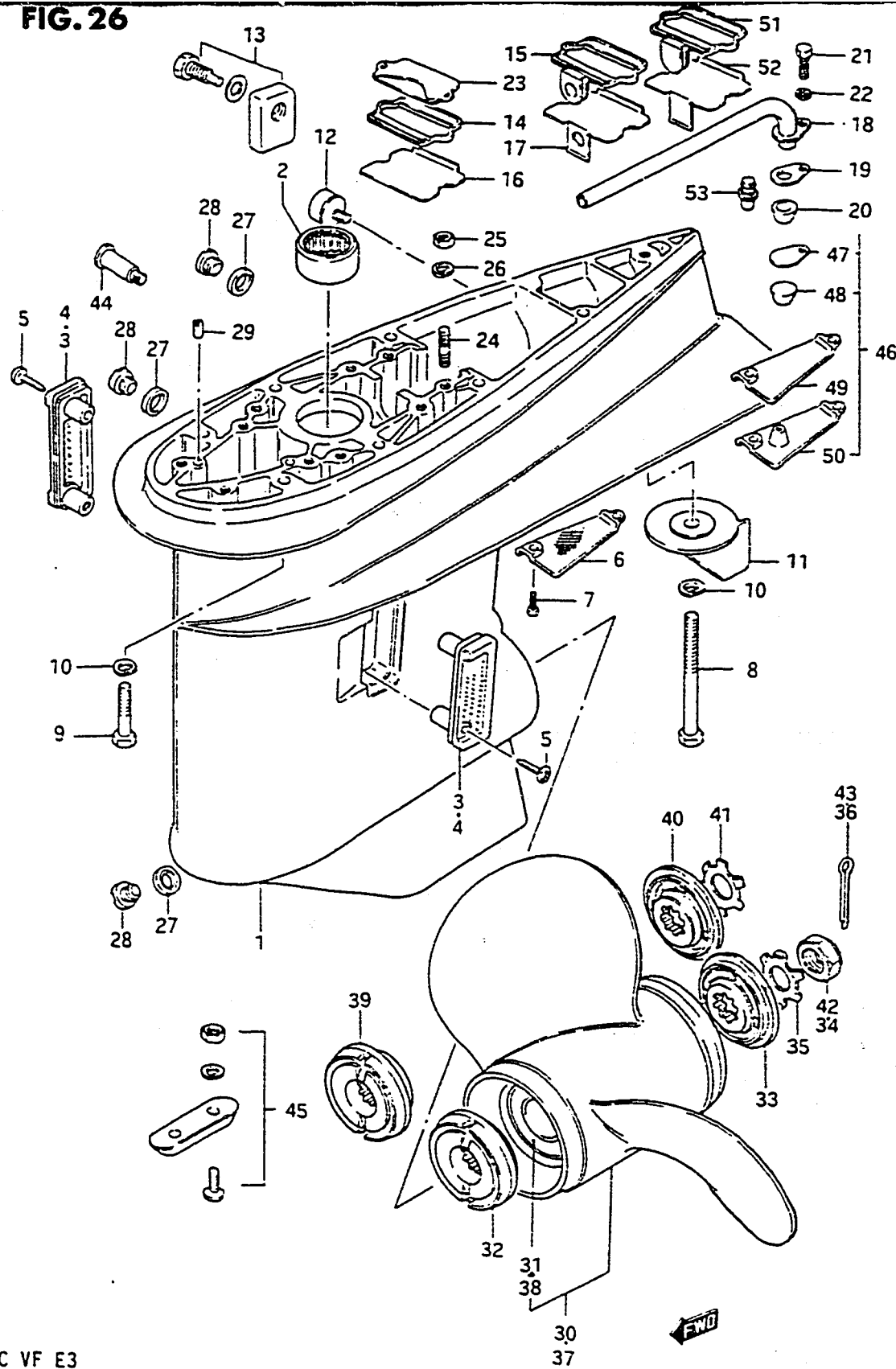


FIG. 26 ( D- 9) GEAR CASE

REF.NO.	PART NO.	DESCRIPTION	Q'TY	REMARKS
1-1	55100-94504-02M	CASE ASSY, gear	1	~304574
1-2	55100-94507-02M	CASE ASSY, gear	1	404575~
2-1	09263-28014	.BEARING, pinion	1	~304574
2-2	09263-28016	.BEARING, pinion	1	404575~
3	17631-94502	FILTER, water	2	
4	17631-95202	FILTER, water	2	model VE/VF
5-1	03112-06309	SCREW	2	~304415
5-2	03112-04309	SCREW	2	304416~
6	17635-94500	FILTER, water sub	1	404575~
7	09125-05046	SCREW	2	404575~
8	09100-10158	BOLT (10x100)	1	
9	09100-10157	BOLT (10x45)	8	
10	09162-10005	LOCK WASHER	9	
11	55125-94501-02M	TRIM TAB	1	
12	55320-93142	ZINC, protection	1	model QD
13	55320-95310	ZINC, protection	1	model VE/VF
14	55332-94503	RUBBER, exhaust seal	1	~304574
15	55332-94510	RUBBER, exhaust seal	1	404575~
16	55333-94500	PLATE	1	~304574
17	55333-94510	PLATE	1	404575~
18	17520-94500	TUBE, water sub	1	404575~
19	17523-94500	GASKET	1	404575~
20	17564-94500	BUSH	1	404575~
21	09100-06115	BOLT (6x15)	1	404575~
22	09162-06001	LOCK WASHER	1	404575~
23	55334-94500	COVER	1	
24	09108-06062	STUD BOLT (6x12)	2	
25	09140-06020	NUT	2	
26	09162-06001	LOCK WASHER	2	
27	09168-10022	GASKET	3	
28	09248-10005	PLUG, drain	3	
29	09206-11001	PIN (L:12)	2	

FIG. 26

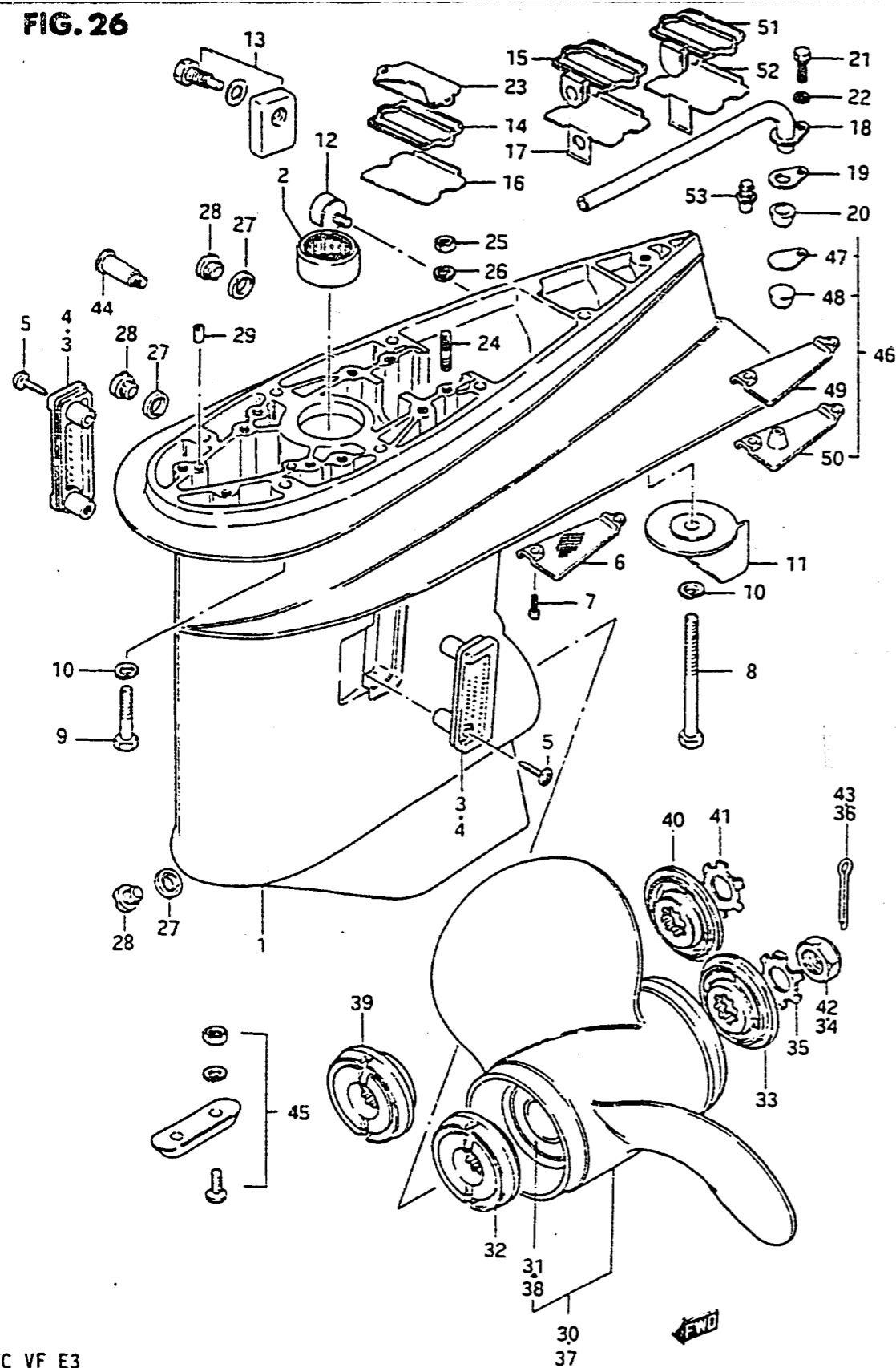


FIG. 26 ( D-10) GEAR CASE

REF.NO.	PART NO.	DESCRIPTION	Q'TY	REMARKS
30-1	58100-95511-01T	PROPELLER (3x13-1/4x17)	1	U1700
30-2	58100-95521-01T	PROPELLER (3x13x19)	1	U1900
31	58120-95500	.BUSH	1	
32	57635-95503	STOPPER	1	U TYPE
33-1	57633-95500	SPACER (OD:52)	1	model QD:U TYPE
33-2	57633-95501	SPACER (OD:50)	1	model VE/VF:U TYPE
34	09159-18004	NUT	1	U TYPE
35	57635-95300	WASHER	1	U TYPE
36	09204-03003	COTTER PIN	1	
37-1	58100-94500-01T	PROPELLER (3x13-1/2x15)	1	V1500
37-2	58100-94553-15M	PROPELLER (3x13-1/2x15)	1	VS1500 STAINLESS
37-3	58100-94511-01T	PROPELLER (3x13-1/4x17)	1	V1700
37-4	58100-94580-15M	PROPELLER (3x13-1/4x17)	1	VS1700 STAINLESS
37-5	58100-94522-01T	PROPELLER (3x13x19)	1	V1900,STD
37-6	58100-94560-15M	PROPELLER (3x13x19)	1	VS1900 STAINLESS
37-7	58100-94532-01T	PROPELLER (3x13x21)	1	V2100
37-8	58100-94570-15M	PROPELLER (3x13x21)	1	VS2100 STAINLESS
38	58120-94520	.BUSH	1	
39-1	57635-94501	STOPPER	1	V TYPE,model QD/VE
39-2	57635-94502	STOPPER	1	V TYPE,model VF
40	57633-94500	SPACER	1	V TYPE
41	57634-94500	WASHER	1	V TYPE
42	09159-18004	NUT	1	V TYPE
43	09204-03003	COTTER PIN	1	
44	55181-95200	ATTACHMENT, flash hose	1	
45	55300-95500	ZINC, protection	1	OPT
46	17500-94520	SEAL ASSY, exhaust	1	OPT,model VE/VF
47	17522-94520	.PLATE, gear case plug	1	OPT,model VE/VF
48	17564-94520	.PLUG, gear case	1	OPT,model VE/VF
49	17635-94520	.PLATE, gear case	1	OPT,model VE
50	17635-94521	.PLATE, gear case	1	OPT,model VF
51	55332-94520	.RUBBER, exhaust seal	1	OPT,model VE/VF
52	55333-94520	.PLATE, exhaust seal under	1	OPT,model VE/VF
53	17636-94500	PLUG, sub water tube	1	OPT

FIG. 27

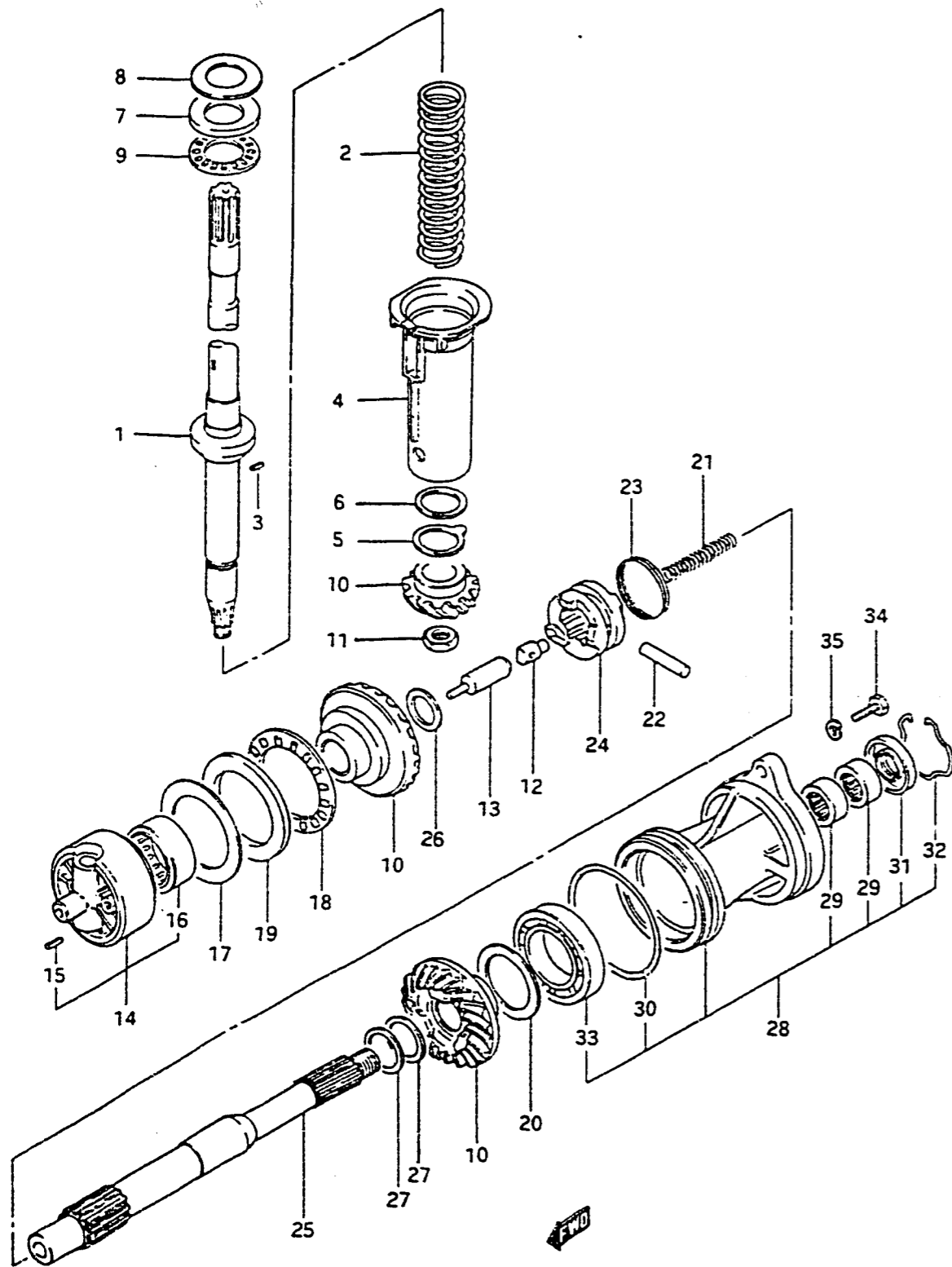


FIG. 27 ( D-11) TRANSMISSION

REF.NO.	PART NO.	DESCRIPTION	Q'TY	REMARKS
1-1	57100-94501	SHAFT ASSY, drive	1	L type
1-2	57100-94511	SHAFT ASSY, drive	1	X type
2	09440-31003	.SPRING, drive shaft	1	
3	09205-04008	.PIN	1	
4	57133-94502	COLLER, drive shaft spring	1	
5	09166-30006	THRUST WASHER (T:2.5)	1	
6	09160-30031	THRUST WASHER (T:2.5)	1	
7	09160-32005	THRUST WASHER (T:4.25)	1	
8-1	09181-30011	SHIM (T:0.7)	1	
8-2	09181-30012	SHIM (T:0.8)	1	
8-3	09181-30013	SHIM (T:0.9)	1	
8-4	09181-30014	SHIM (T:1.0)	1	
8-5	09181-30015	SHIM (T:1.1)	1	
8-6	09181-30016	SHIM (T:1.2)	1	
8-7	09181-30017	SHIM (T:1.3)	1	
8-8	09181-30018	SHIM (T:0.6)	1	
9	09269-30008	BEARING	1	
10-1	57300-94821	PINION/GEAR SET	1	model QD
10-2	57300-94830	PINION/GEAR SET	1	model VE/VF
11	09140-16021	NUT	1	
12-1	57632-95501	PIN, push (ID:6)	1	model QD
12-2	09209-12007	PIN, push (ID:7)	1	model VE/VF
13-1	57631-94500	ROD, push (L:77)	1	model QD
13-2	57631-94501	ROD, push (L:77)	1	model VE/VF
13-3	57631-94510	ROD, push (L:76.5)	1	
13-4	57631-94520	ROD, push (L:77.5)	1	
14-1	56140-94501	HOUSING, forward gear bearing	1	model QD
14-2	56140-94510	HOUSING, forward gear bearing	1	model VE/VF
15	09205-05011	.PIN (L:14)	1	
16	09263-50001	.BEARING	1	
17-1	09181-70001	SHIM (T:0.7)	0-1	
17-2	09181-70002	SHIM (T:0.8)	1	
17-3	09181-70003	SHIM (T:0.9)	1	
17-4	09181-70004	SHIM (T:1.0)	1	
17-5	09181-70005	SHIM (T:0.5)	0-1	
17-6	09181-70006	SHIM (T:0.6)	0-2	



FIG. 27

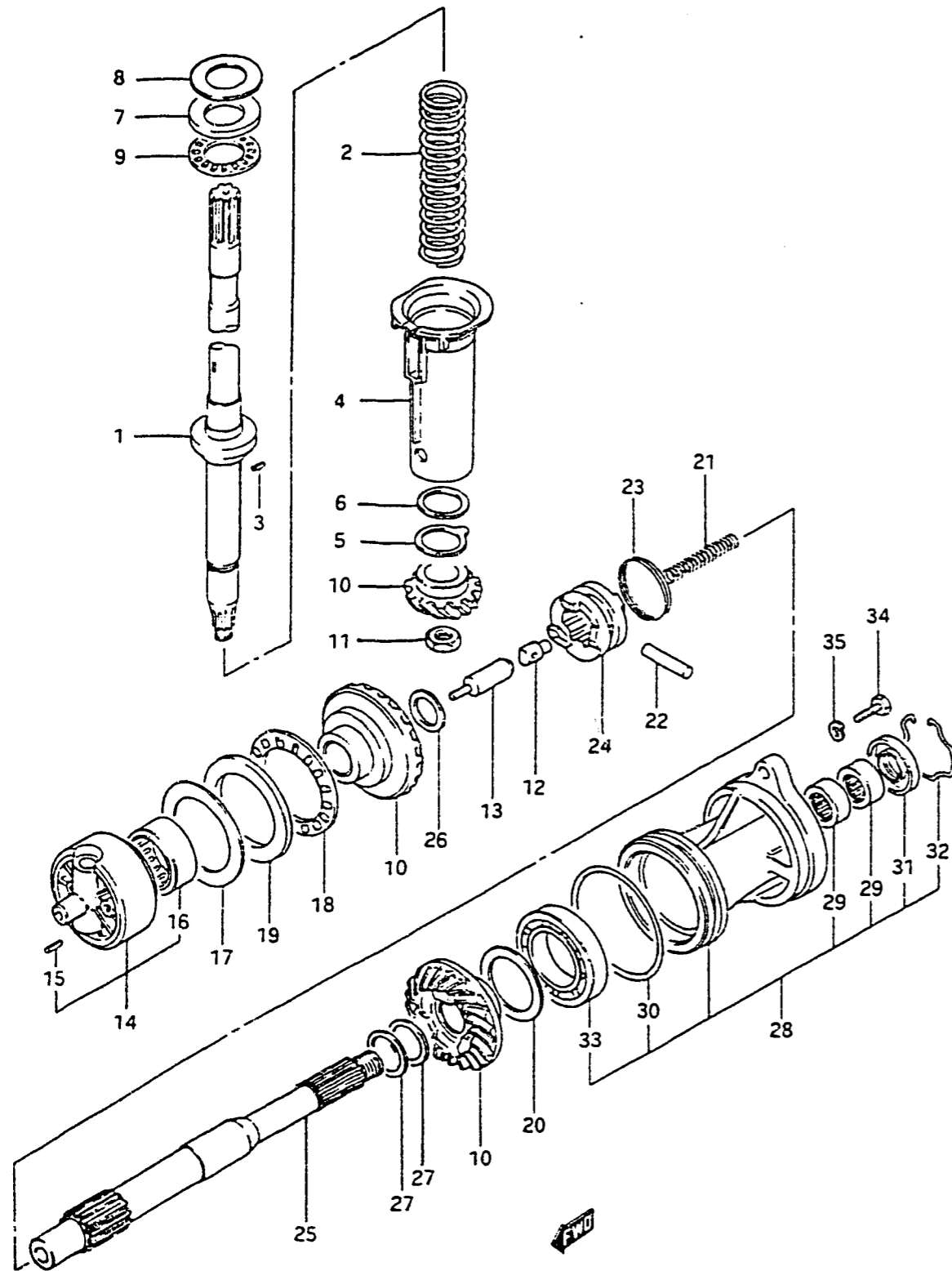
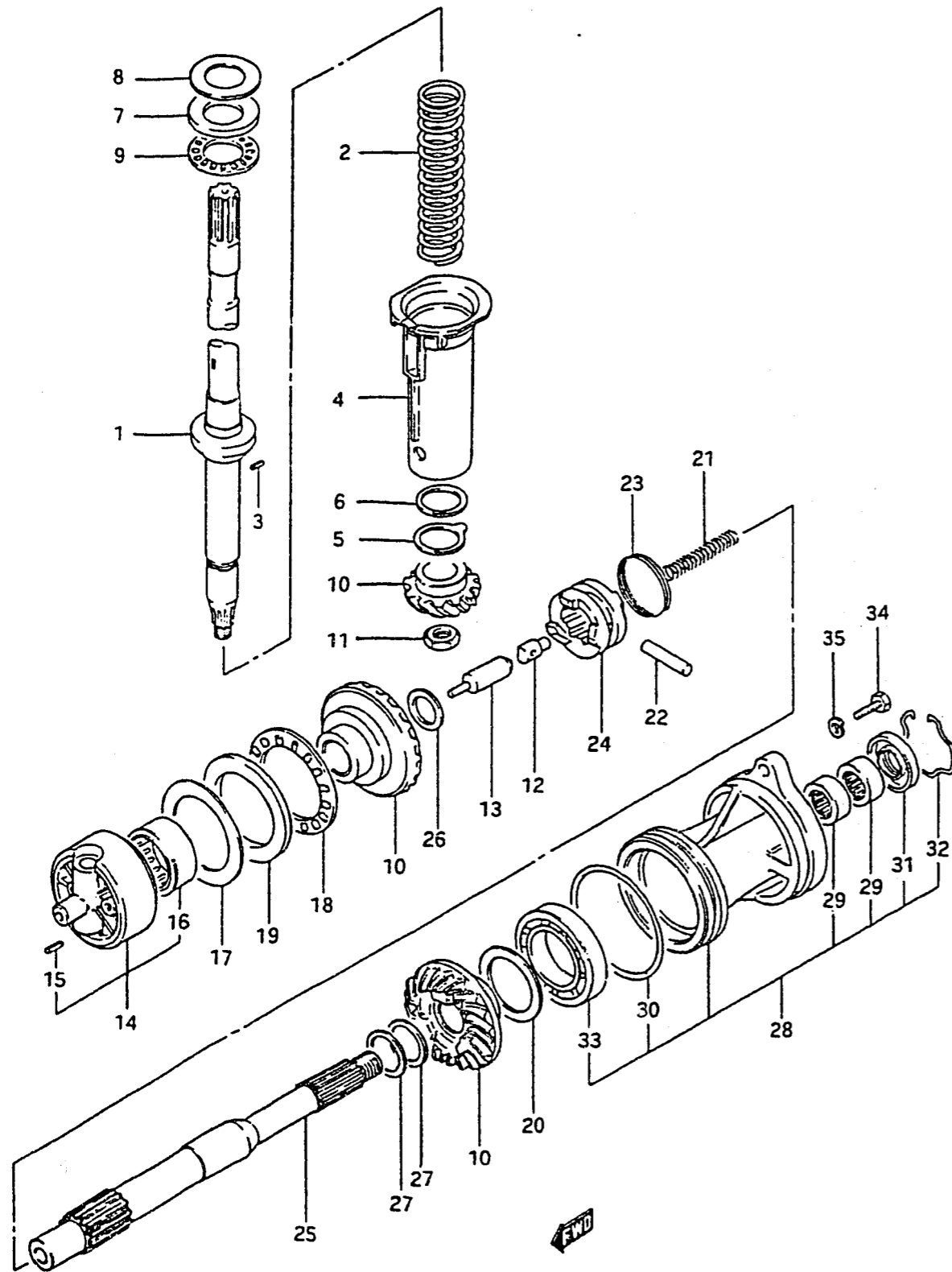


FIG. 27 ( D-12) TRANSMISSION

REF.NO.	PART NO.	DESCRIPTION	Q'TY	REMARKS
18	09269-70001	BEARING	1	
19	09160-70002	THRUST WASHER (T:5.25)	1	
20-1	09181-45003	SHIM (T:1.0)	1	
20-2	09181-45004	SHIM (T:1.1)	1	
20-3	09181-45005	SHIM (T:1.2)	1	
20-4	09181-45006	SHIM (T:1.3)	1	
20-5	09181-45007	SHIM (T:1.4)	1	
20-6	09181-45008	SHIM (T:1.5)	1	
20-7	09181-45009	SHIM (T:1.6)	1	
21-1	09440-08017	SPRING (L:65)	1	model QD
21-2	09440-11020	SPRING (L:67)	1	model VE/VF
22-1	09202-06020	PIN (6x48)	1	model QD
22-2	09202-07002	PIN (7x48)	1	model VE/VF
23-1	09440-49001	SPRING (L:30)	1	~405822
23-2	09440-50002	SPRING (L:6.75)	1	405823~
24-1	57621-94502	SHIFTER, clutch dog	1	model QD
24-2	57621-94510	SHIFTER, clutch dog	1	404575~405677
24-3	57621-94511	SHIFTER, clutch dog	1	40568~406189
24-4	57621-94512	SHIFTER, clutch dog	1	406188~
25-1	57610-94504	SHAFT, propeller	1	model QD
25-2	57610-94505	SHAFT, propeller	1	model VE
25-3	57610-94506	SHAFT, propeller	1	model VF
26	09181-25030	THRUST WASHER (T:3.0)	1	
27-1	09160-28013	THRUST WASHER (T:1.0)	0~2	
27-2	09160-28014	THRUST WASHER (T:1.2)	0~2	
27-3	09160-28015	THRUST WASHER (T:1.4)	0~2	
27-4	09160-28016	THRUST WASHER (T:1.6)	0~2	
27-5	09160-28018	THRUST WASHER (T:1.3)	0~2	

FIG. 27

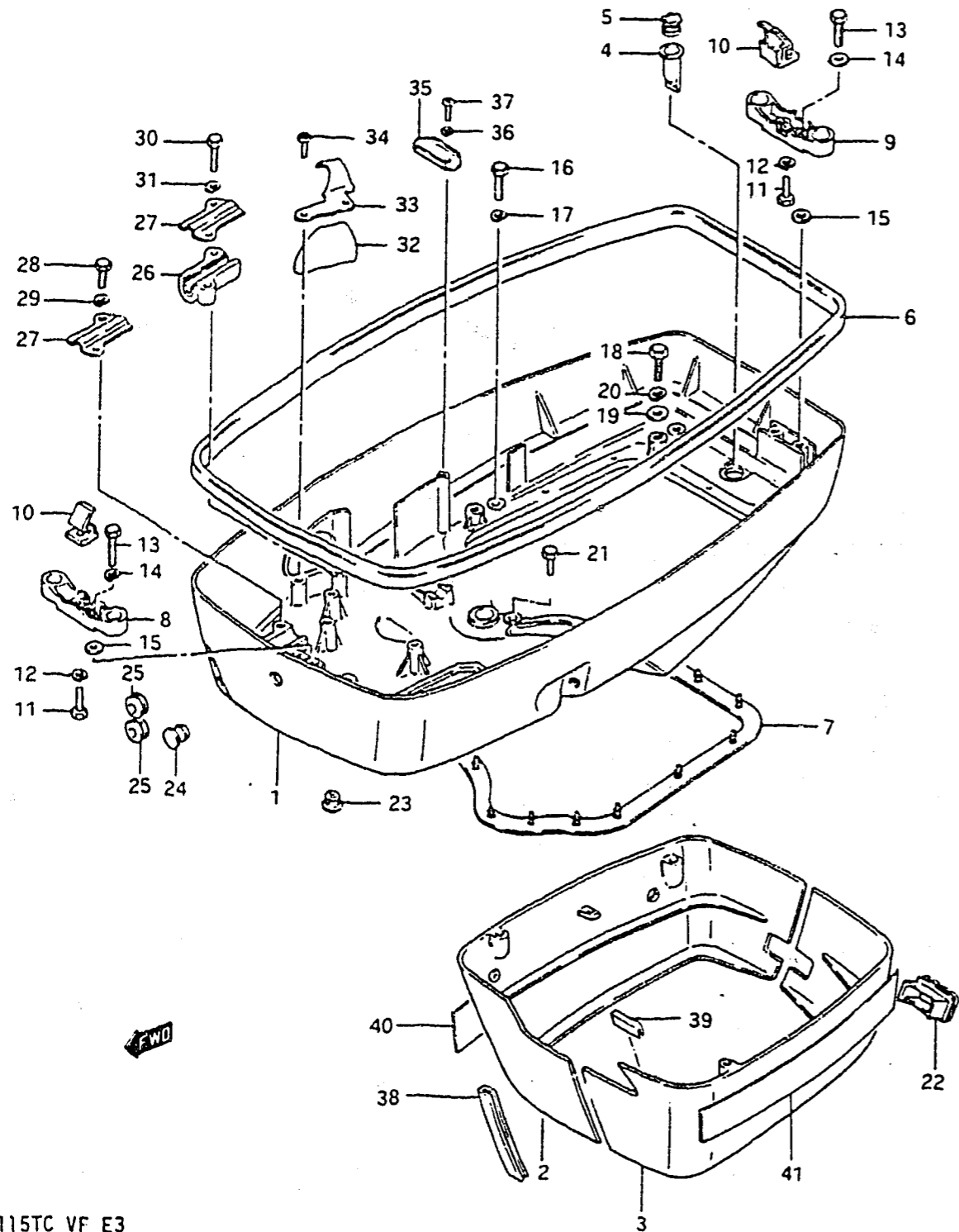
FIG. 27 ( D-13) TRANSMISSION



REF.NO.	PART NO.	DESCRIPTION	Q'TY	REMARKS
28-1	56120-94501	HOUSING, propeller shaft	1	model QD
28-2	56120-94502	HOUSING, propeller shaft	1	model VE/VF
29	09263-28013	.BEARING	2	
30	09280-97001	.O RING	1	
31-1	09289-28006	.OIL SEAL	1	model QD
31-2	09282-28002	.OIL SEAL	2	model VE/VF
32	09387-52001	.RING	1	
33	08113-60090	.BEARING	1	
34	09100-08168	BOLT (8x30)	2	
35	09162-08007	LOCK WASHER	2	

FIG. 28

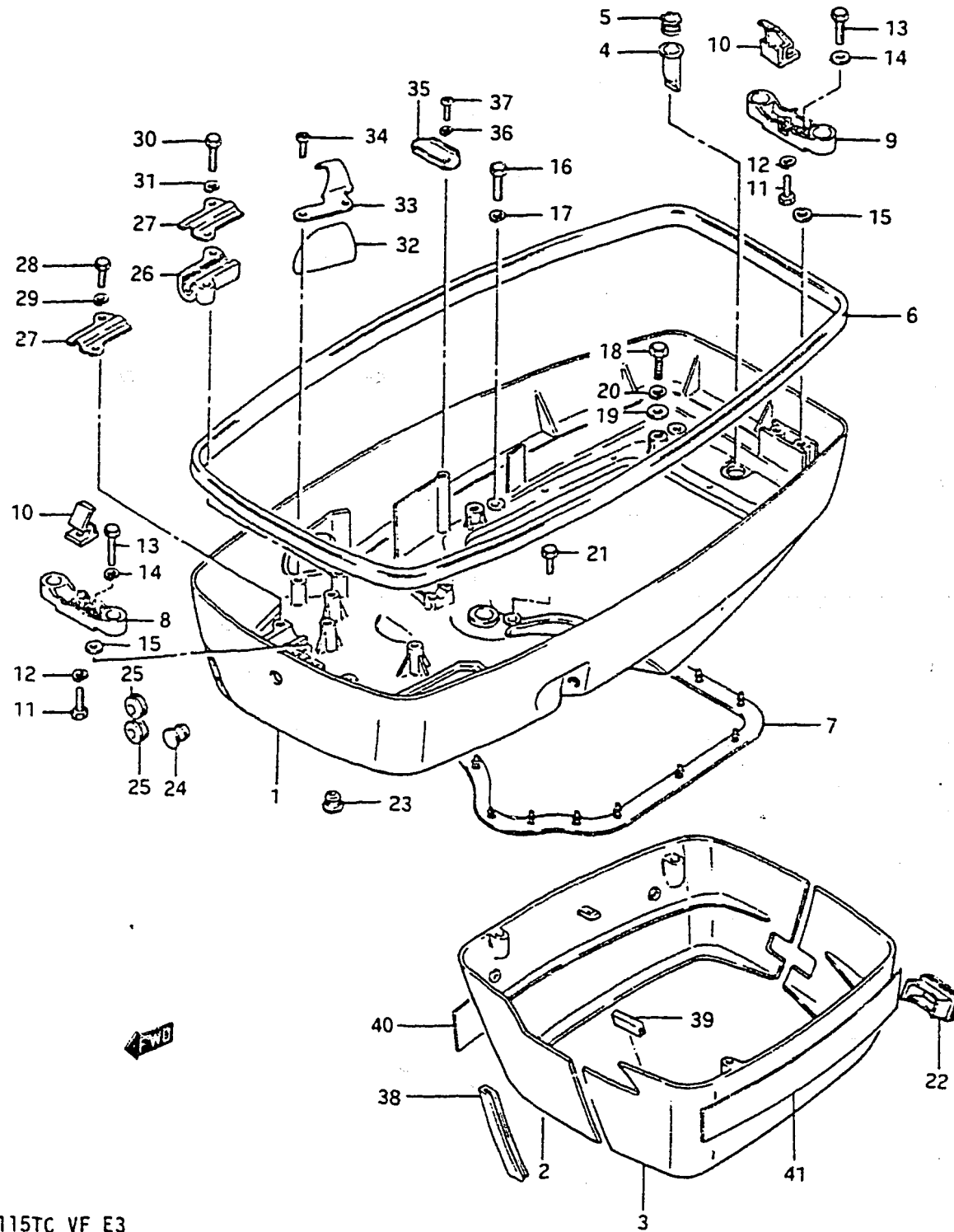
FIG. 28 ( E- 2) LOWER COVER



REF.NO.	PART NO.	DESCRIPTION	Q'TY	REMARKS
1-1	61110-94507-02M	COVER, lower	1	-404581
1-2	61110-94508-02M	COVER, lower	1	404582~
2	61131-94502-02M	COVER, engine holder RH	1	
3	61141-94503-02M	COVER, engine holder LH	1	
4-1	13873-20300	TUBE, drain	1	-404581
4-2	61139-94500	TUBE, drain	1	404582~
5	13979-37400	RETAINER, drain tube	1	
6-1	61112-94501	SEAL, lower cover upper	1	model QD/VE
6-2	61112-94502	SEAL, lower cover upper	1	model VF
7	61113-94503	SEAL, lower cover lower	1	
8-1	61115-94501	HOLDER, front	1	-304274
8-2	61115-94502	HOLDER, front	1	304275~
9-1	61116-94500	HOLDER, locating bracket rear	1	-304274
9-2	61116-94501	HOLDER, locating bracket rear	1	304275~
10	61631-94500	HOOK, locating holder	2	
11	09100-06115	BOLT	2	
12	09162-06001	LOCK WASHER	2	
13-1	09100-06083	BOLT (6x30)	4	-304546
13-2	09100-06120	BOLT (6x25)	4	304547~
14	09160-06082	WASHER	4	
15	09160-06082	WASHER	0~12	
16-1	09100-06083	BOLT (6x30)	4	model QD/VE
16-2	09128-06052	BOLT (6x26)	4	model VF
17	09162-06001	LOCK WASHER	4	
18	09100-08214	BOLT (8x50)	4	
19-1	09160-08082	WASHER (8.5x16x1.2)	6	
19-2	09181-08007	WASHER (8.5x16x0.5)	2	
20	09162-08007	LOCK WASHER	4	
21	09100-06089	BOLT (6x25)	1	

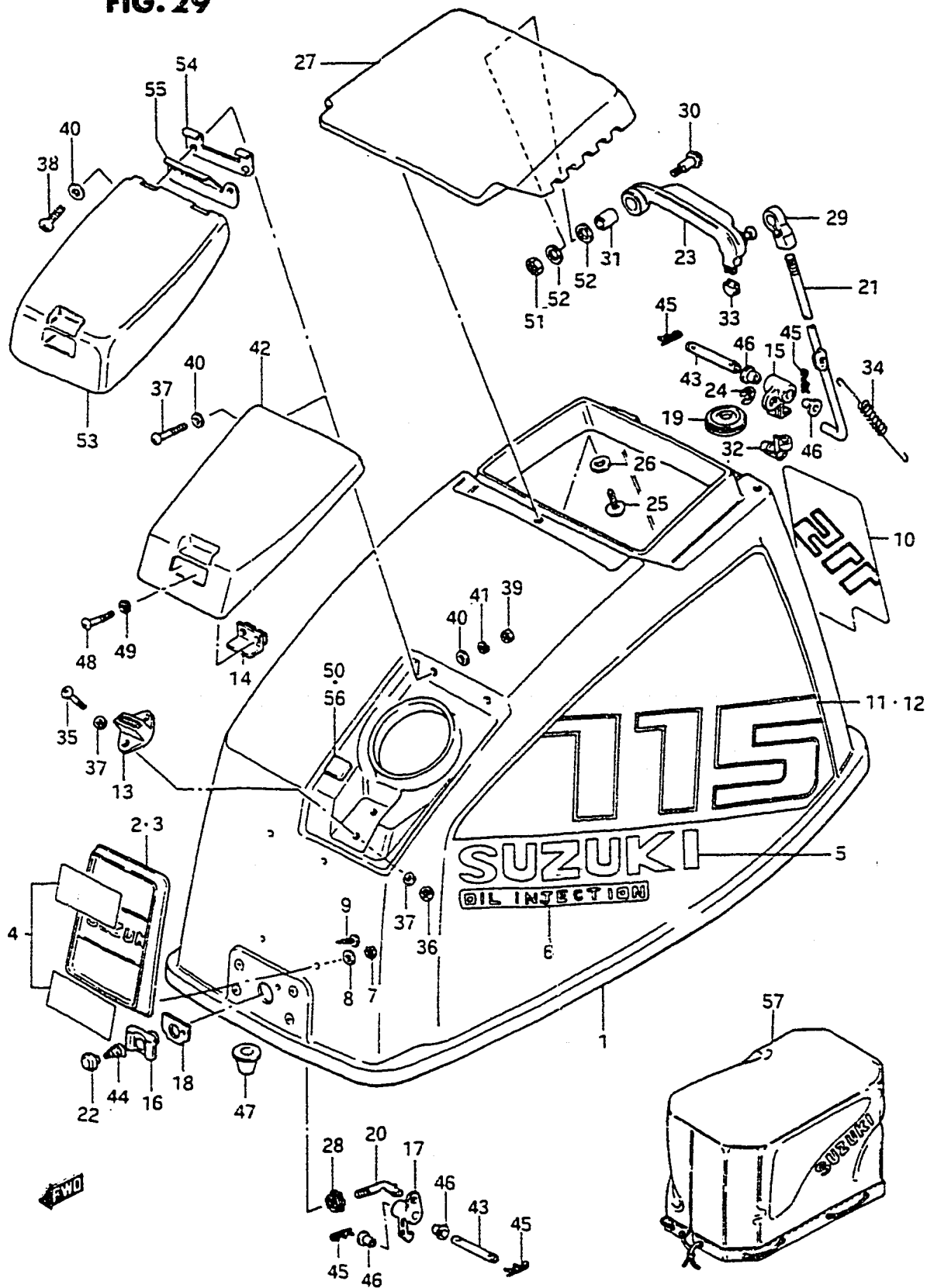
FIG. 28

FIG. 28 ( E- 3) LOWER COVER



REF.NO.	PART NO.	DESCRIPTION	Q'TY	REMARKS
27	61142-94502	GROMMET	1	
23	09250-09001	CAP, steering joint	1	
24	09250-10012	CAP, carburetor adjust	1	
25	09308-08013	GROMMET, remocon cable	2	
26	67271-94500	HOLDER, remocon cable	1	
27	67276-94502	PLATE, remocon cable holder	2	
28-1	09100-06019	BOLT (6x16)	2	model QD/VE
28-2	09100-06117	BOLT (6x35)	2	model VF
29	09162-06006	LOCK WASHER	2	
30	09100-06117	BOLT (6x35)	2	
31	09162-06001	LOCK WASHER	2	
32-1	36656-94502	GROMMET, cable	1	model QD
32-2	36656-94511	GROMMET, cable	1	model VE/VF
33	36659-94503	CLAMP, grommet	1	
34	09125-06021	SCREW	2	
35	33815-94500	PROTECTOR	1	
36	08321-21062	LOCK WASHER	1	
37	02112-06122	SCREW	1	
38	13851-95210	CUSHION	1	L:585+82
39	61136-94500	CUSHION	2	L:30
40	61221-94560	TAPE, lower cover RH	1	
41	61231-94560	TAPE, lower cover LH	1	

FIG. 29



DT115TC VF E3

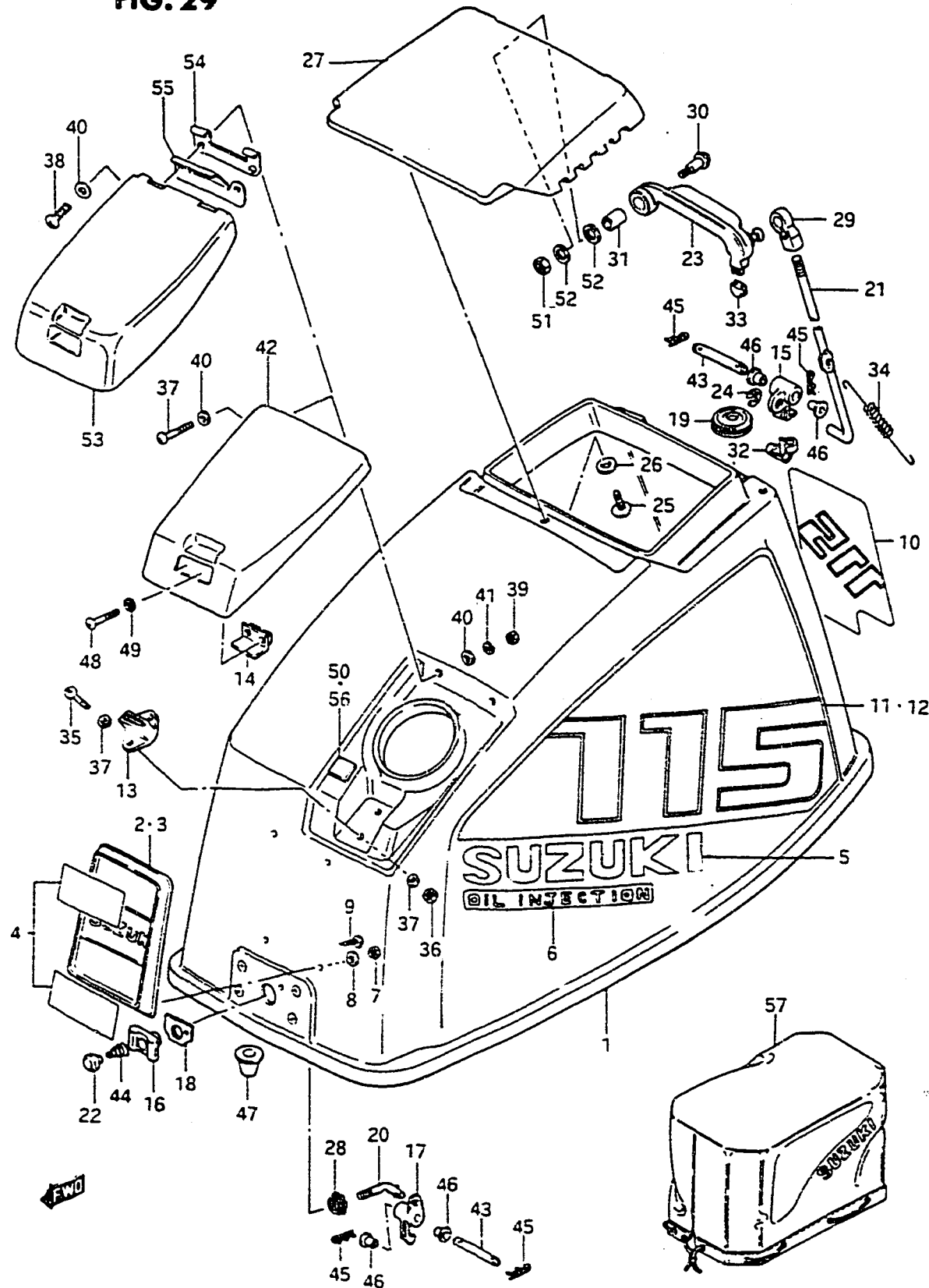
FIG. 29 ( E- 4) ENGINE COVER

REF.NO.	PART NO.	DESCRIPTION	Q'TY	REMARKS
1-1	61400-94880-02M	COVER SE1, engine	1	model QD
1-2	61400-94881-02M	COVER SE1, engine	1	model VE
1-3	61400-94882-02M	COVER SE1, engine	1	model VF
2	61420-95510	.EMBLEM, front	1	model QD/VE
3	61421-94400	.EMBLEM, front	1	model VF
4	61422-95561	.MARK, upper	1	
5	61441-94560	.EMBLEM, side	2	
6	61442-94560	.MARK, oil injection	2	
7	09140-05001	.NUT	4	model QD/VE
8	09160-05024	.WASHER	4	model QD/VE
9	03242-05109	.SCREW	4	model VF
10	61435-94560	.EMBLEM, rear	1	
11	61443-94560	.TAPE, stripe RH	1	
12	61453-94560	.TAPE, stripe LH	1	
13	61540-94500	.MAGNET, oil filler lid catch	1	-304004
14	61551-94502	.RETAINER, magnet catch	1	-304004
15	61641-94501	.HOOK, cover release	1	
16	61651-95501	.HOLDER, hook spring	1	
17	61641-95500	.HOOK, release	1	
18	61652-95500	.PACKING, hook spring holder	1	
19	61652-94501	.GROMMET, latch release rod	1	
20	61653-95501	.SHAFT, release hook	1	
21-1	61653-94501	.ROD, latch release	1	model QD
21-2	61653-94502	.ROD, latch release	1	model VE/VF
22	61660-95500	.KNOB, hook	1	
23-1	61661-94500	.LEVER, lower cover latch	1	-304005
23-2	61661-94501	.LEVER, lower cover latch	1	304006-
24	09383-03001	.E RING	1	for 61653-94502
25	03242-06169	.SCREW, tilt handle	4	
26	08322-21067	.WASHER	4	

DT115TC VF E3

FIG. 29

FIG. 29 ( E- 5) ENGINE COVER

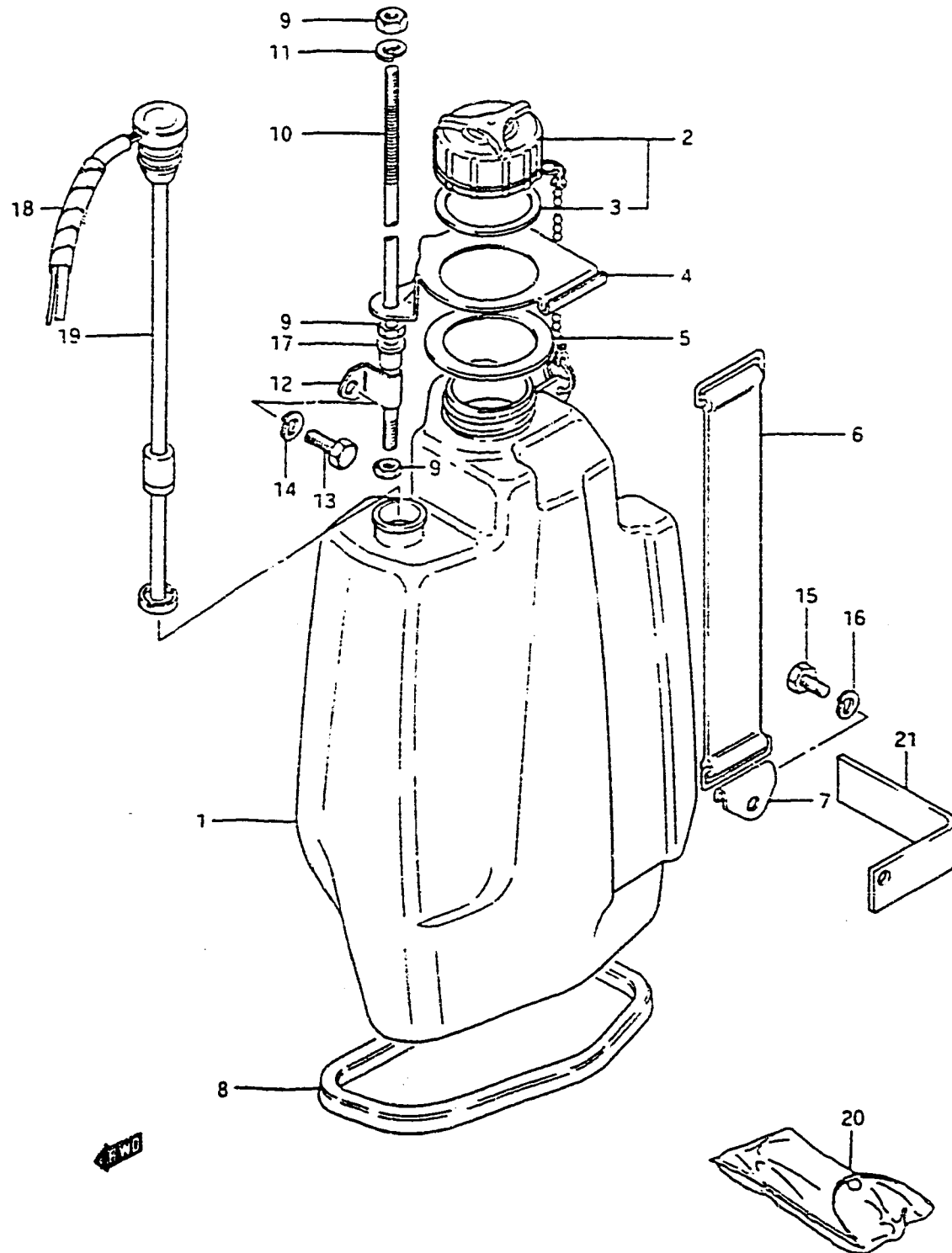


Q'TY

REF.NO.	PART NO.	DESCRIPTION	Q'TY	REMARKS
27-1	61431-94500-02M	.HANDLE, tilt up	1	-304005
27-2	61431-94501-02M	.HANDLE, tilt up	1	304006-
28	61654-95500	.NUT	1	
29	19131-95502	.CONNECTOR, latch release rod	1	
30	09103-06046	.BOLT	1	-304005
31	09180-06097	.SPACER	1	-304005
32	09209-05017	.PIN, linkage	1	
33	09259-04001	.STOPPER	1	-304005
34	09443-06040	.SPRING	1	
35	09125-05029	.SCREW	2	-304005
36	09140-05001	.NUT	2	-304005
37	09160-05010	.WASHER (5.5x10x0.8)	4	-304005
38	09125-06021	.SCREW	2	
39	09140-06020	.NUT	2	
40	09160-06055	.WASHER (7x12x1)	4	
41	08321-21067	.LOCK WASHER	2	
42	61480-94502-02M	.LID, oil tank filler	1	-304004, to 61481-94502-02M with 61482-94510, 61485-94500 and 61544-94500
43	61642-95500	.PIN	2	
44	09441-12001	.SPRING	1	
45	09385-06003	.PIN	4	
46	09301-06005	.BUSHING	4	
47	09329-08002	.CUSHION	4	
48	02112-04082	.SCREW	2	-304004
49	08322-21042	.WASHER	2	-304004
50	66511-78000	.PAD, oil tank filler lid	1	-304004
51	08310-22068	.NUT	1	-304005
52	09160-06062	.WASHER	2	-304005
53	61481-94502-02M	.LID, oil tank filler	1	304005-
54	61482-94510	.HINGE	1	304005-
55	61485-94500	.SPRING	1	304005-
56	61544-94500	.PAD	1	304005-
57	68110-94510	COVER, weather	1	OPT

FIG. 30

FIG. 30 ( E- 6) OIL TANK



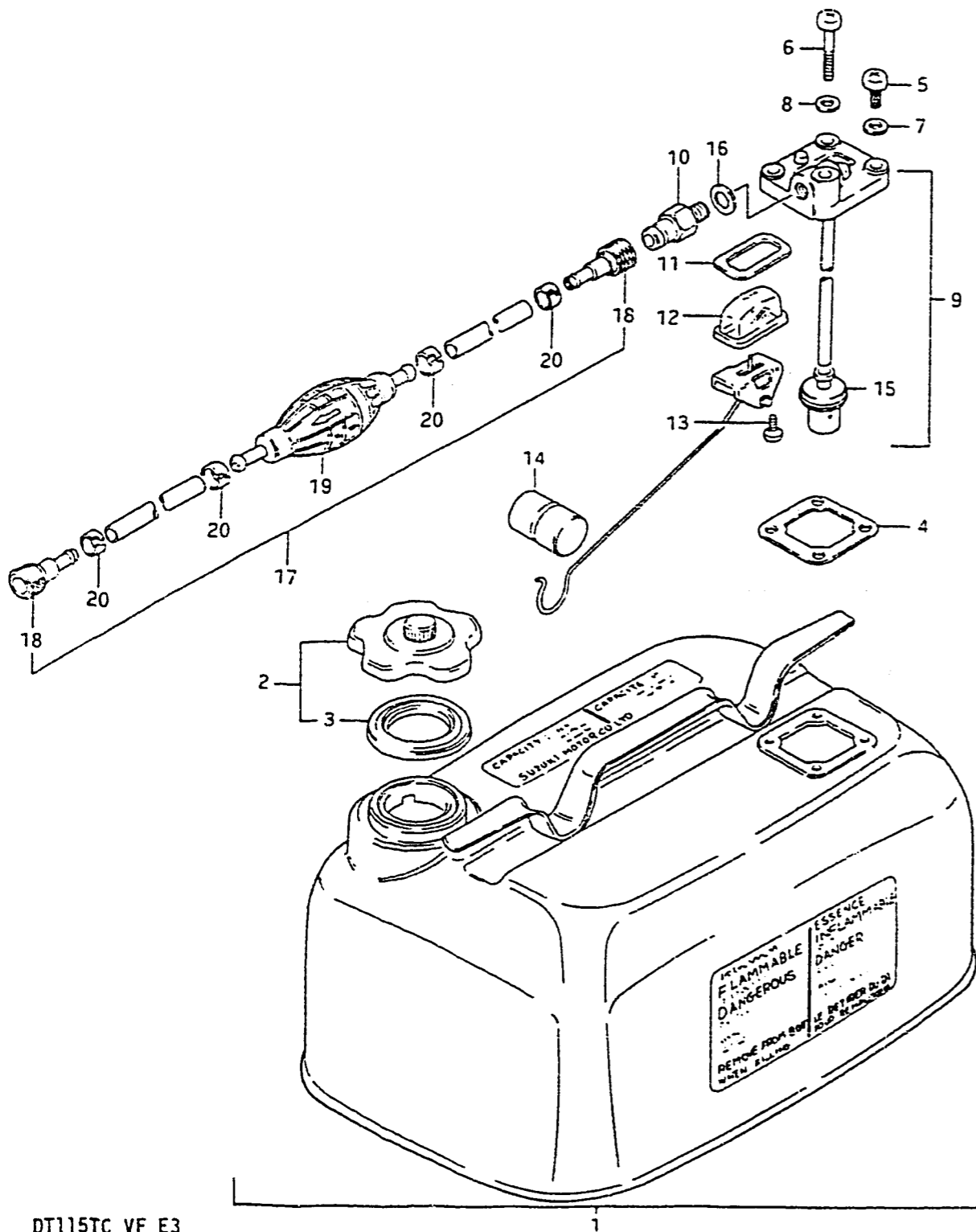
REF.NO.	PART NO.	DESCRIPTION	Q'TY	REMARKS
1	69110-94500	TANK, oil	1	
2	69200-94502	CAP ASSY, oil tank filler	1	
3	69241-94500	.GASKET	1	
4	69311-94500	SUPPORT, oil tank	1	
5	09320-43001	CUSHION, upper	1	
6	09462-00074	BAND	1	
7	69321-94500	CLAMP, oil tank band	1	
8	09329-02003	CUSHION, lower	1	
9	09140-06004	NUT	3	
10-1	69331-94501	ROD, oil tank support rod	1	model QD
10-2	69331-94503	ROD, oil tank support rod	1	model VE/VF
11	09162-06001	LOCK WASHER	1	
12	69322-94501	CLAMP, oil tank support rod	1	
13	01107-06162	BOLT	1	
14	08321-21062	LOCK WASHER	1	
15	01107-06162	BOLT	1	
16	08321-21062	LOCK WASHER	1	
17	69323-94500	CUSHION, tank support rod	1	
18	38423-95501	TUBE, oil level switch	1	
19-1	34860-94502	SWITCH, oil level	1	model QD
19-2	34860-94510	SWITCH, oil level	1	model VE/VF
20	09800-81800	TOOL KIT	1	
21	69341-94500	STOPPER OIL TANK	1	

FIG.31

FIG.31 ( E- 7) FUEL TANK

Q'TY

REF.NO.	PART NO.	DESCRIPTION	Q'TY	REMARKS
1-1	65000-95200	TANK SE1, fuel (23L)	1	model QD:6 U.S.GAL./ 3.3IMP.GAL.
1-2	65000-95201	TANK SE1, fuel (23L)	1	model VE/VF:6 U.S.GAL./ 3.3IMP.GAL.
2-1	65510-98506	.CAP	1	model QD
2-2	65510-98507	.CAP	1	model VE/VF
3	65561-98502	..GASKET	1	
4	65871-93010	..GASKET	1	
5	02112-06162	..SCREW	3	
6	02112-06402	..SCREW	1	
7-1	09168-06002	..WASHER	3	model QD/VE
7-2	09168-06002	..WASHER	4	model VF
8	08322-21062	..WASHER	1	model QD/VE
9-1	65850-95504	..GAUGE ASSY	1	model QD
9-2	65850-95505	..GAUGE ASSY	1	model VE
9-3	65850-95506	..GAUGE ASSY	1	model VF
10	65740-95500	..CONNECTOR, male fuel	1	OD:13
11	65854-93001	..GASKET, strainer	1	
12	65853-93001	..CAP	1	
13	02112-04102	..SCREW	2	
14	65864-95200	..FLOAT	1	
15	65830-95500	..FILTER	1	
16	09168-12001	..GASKET	1	
17	65700-95513	HOSE, tank / connector	1	
18	65750-95500	..CONNECTOR, female fuel	2	ID:13
19	65770-95501	..PUMP, squeeze	1	
20	65781-98500	..CLIP	4	



DT115TC VF E3

DT115TC VF E3

E7



FIG.32

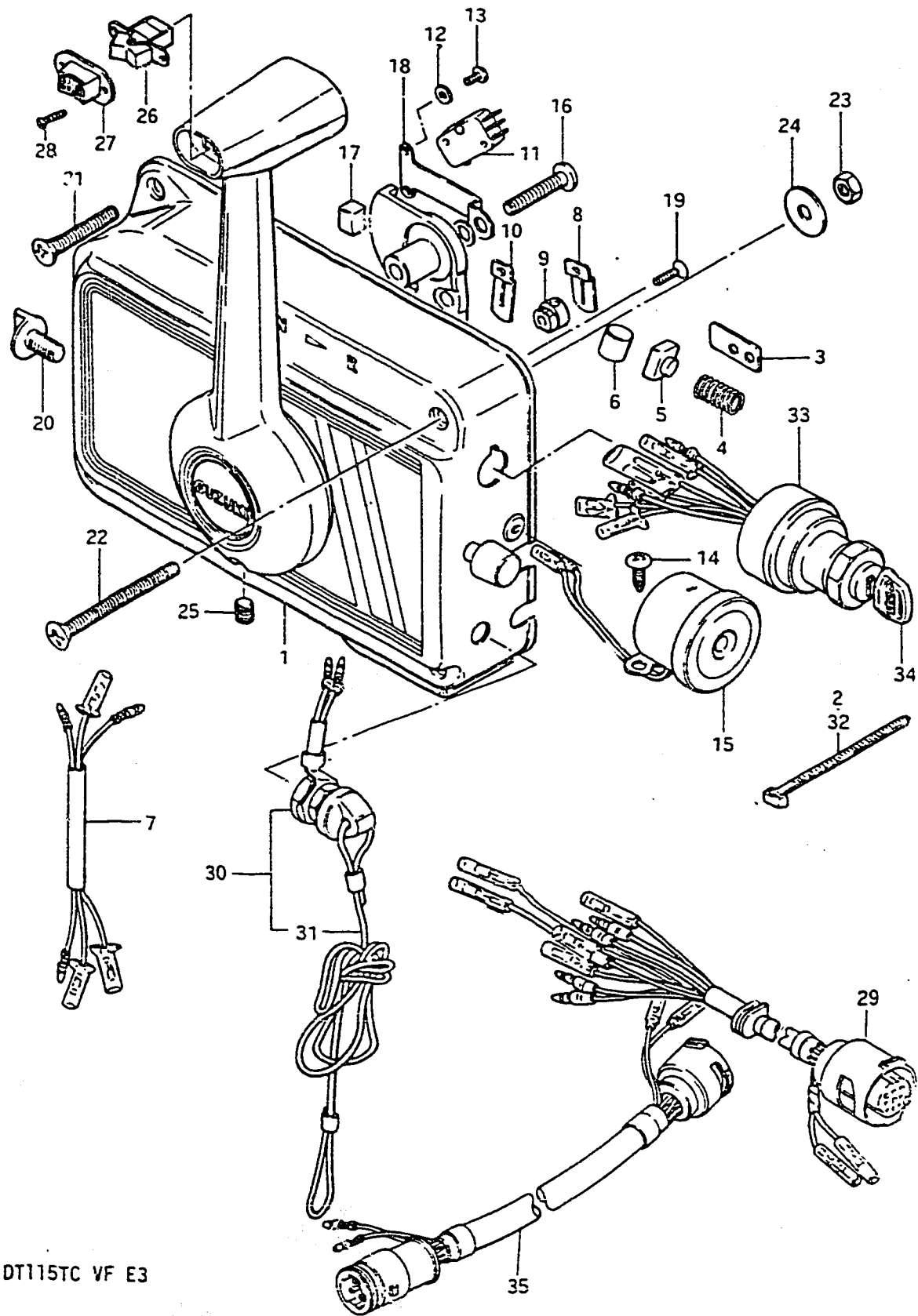


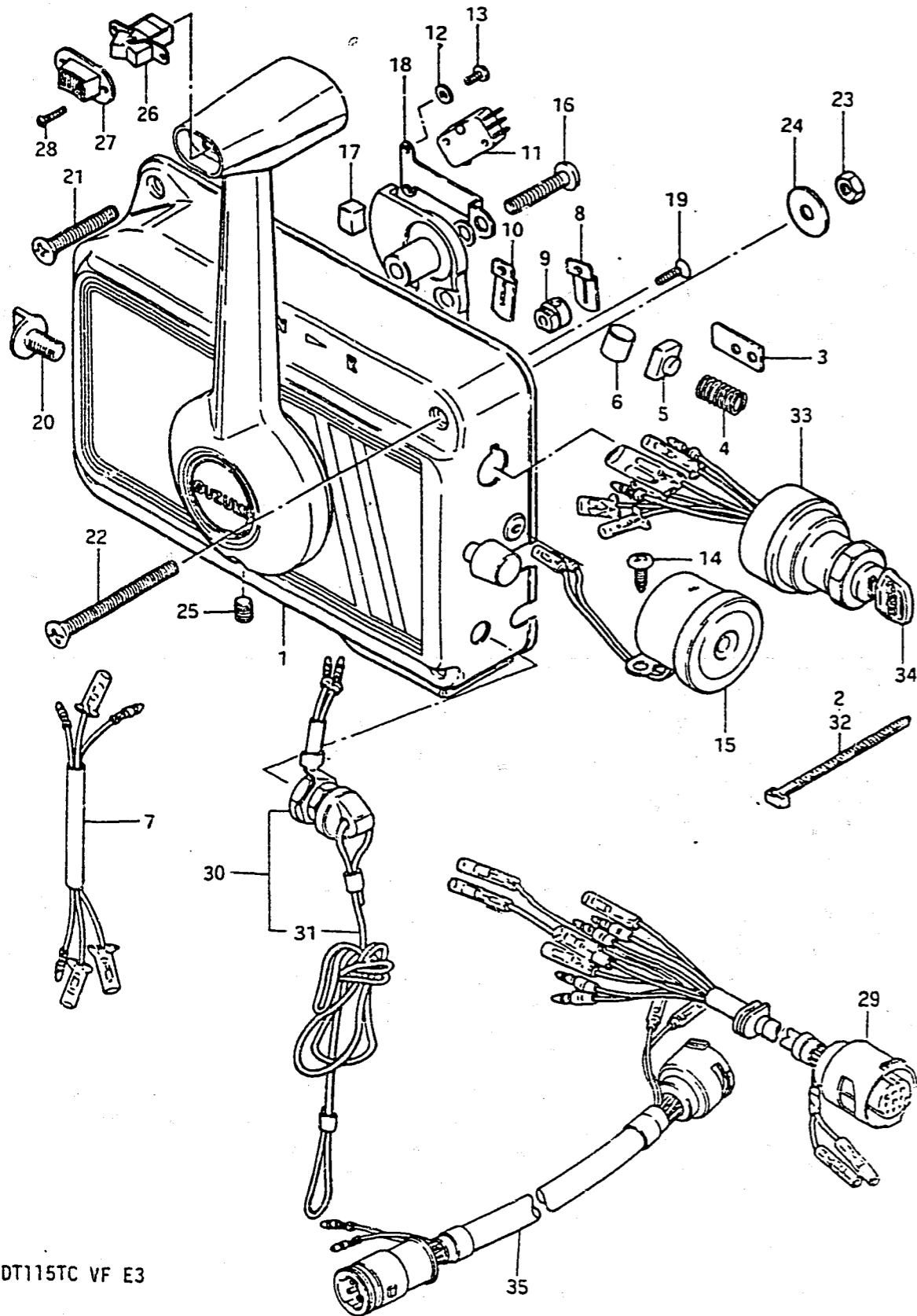
FIG.32 ( E- 8) REMOTE CONTROL (1)

Q'TY

REF.NO.	PART NO.	DESCRIPTION	Q'TY	REMARKS
1	6-200-94520	REMOTE CONTROL BOX ASSY	1	model QD
2	36632-95501	.CLAMP	3	
3	67271-95500	.PLATE	2	
4	67255-95500	.SPRING	1	
5	67254-95500	.BUSHING	1	
6	67253-95500	.ROLLER	1	
7	37863-95501	.CORD, trim	1	
8	67274-95500	.RETAINER, throttle	1	
9	67275-95500	.TRUNNION	2	
10	67272-95500	.RETAINER, clutch	1	
11	37721-95551	.SWITCH, neutral	1	
12	08323-31058	.WASHER	9	
13	02112-05107	.SCREW	9	
14	03142-05169	.TAPPING SCREW	2	
15	38500-94501	.BUZZER	1	
16	02112-06358	.SCREW	1	
17	67234-95500	.SHOW	1	
18	67233-95500	.RETAINER	1	
19	02122-04128	.SCREW	4	
20	67232-95500	.KNOB, brake	1	
21	02132-06408	.SCREW	1	
22	02132-06758	.SCREW	3	
23	08310-11068	.NUT	4	
24	67288-94310	.WASHER	4	
25	67249-95500	.SCREW	1	
26	37860-95501	.SWITCH, trim	1	
27	37864-95500	.CAP, switch	1	
28	09139-02003	.SCREW	2	
29	36620-94310	.WIRING HARNESS	1	
30	37820-95254	.SWITCH, emergency	1	
31	37823-95251	..CAP & ROPE	1	
32	36632-95501	.CLAMP	1	

FIG. 32

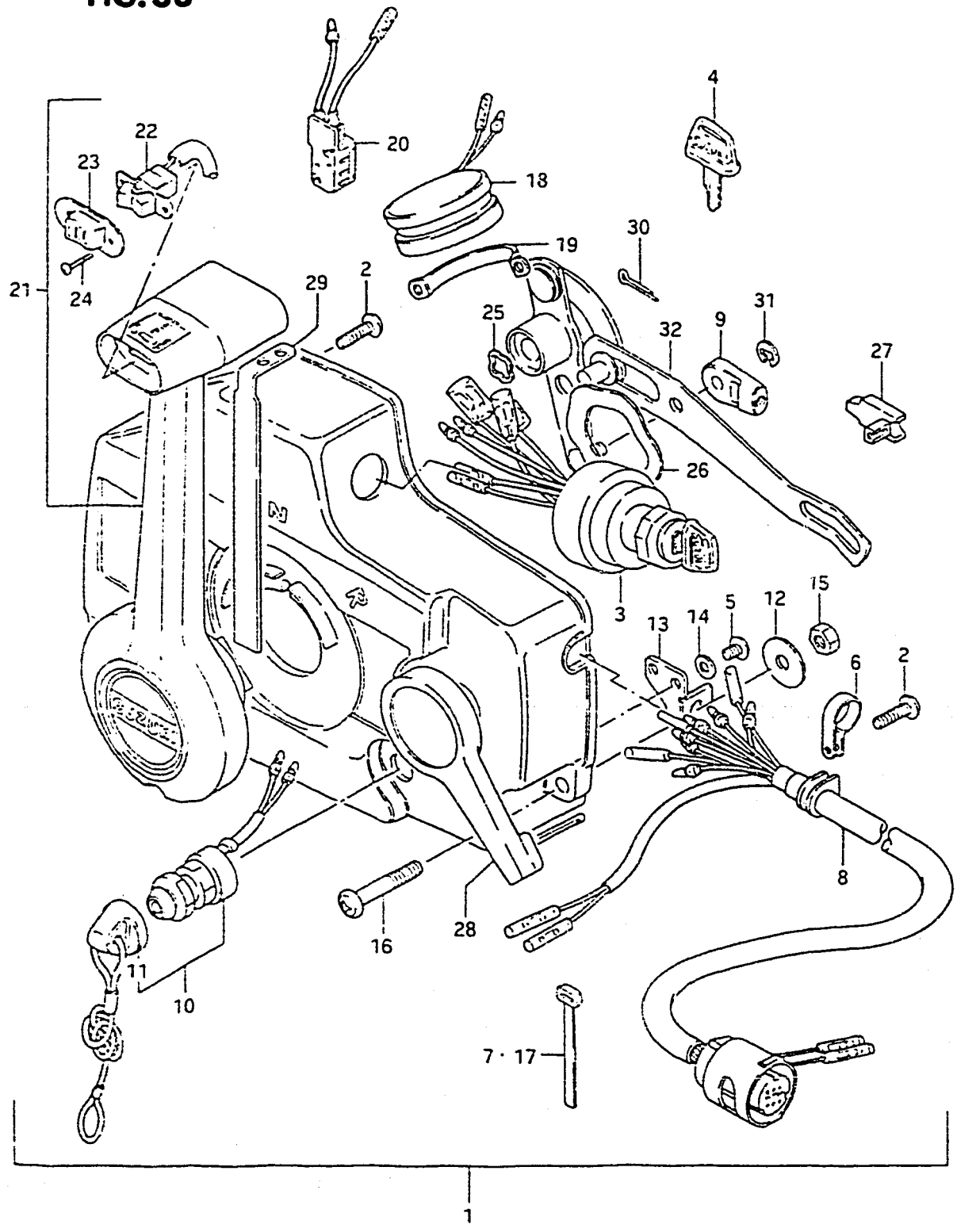
FIG. 32 ( E- 9) REMOTE CONTROL (1)



REF.NO.	PART NO.	DESCRIPTION	Q'TY	REMARKS
33	37110-94301	.SWITCH, ignition	1	
34-1	37141-93300	..KEY, spare (8511)	1	
34-2	37141-93310	..KEY, spare (8512)	1	
34-3	37141-93320	..KEY, spare (8513)	1	
34-4	37141-93330	..KEY, spare (8611)	1	
34-5	37141-93340	..KEY, spare (8612)	1	
34-6	37141-93350	..KEY, spare (8613)	1	
35	36620-95320	WIRING HARNESS, extention	1	OPT

FIG. 33

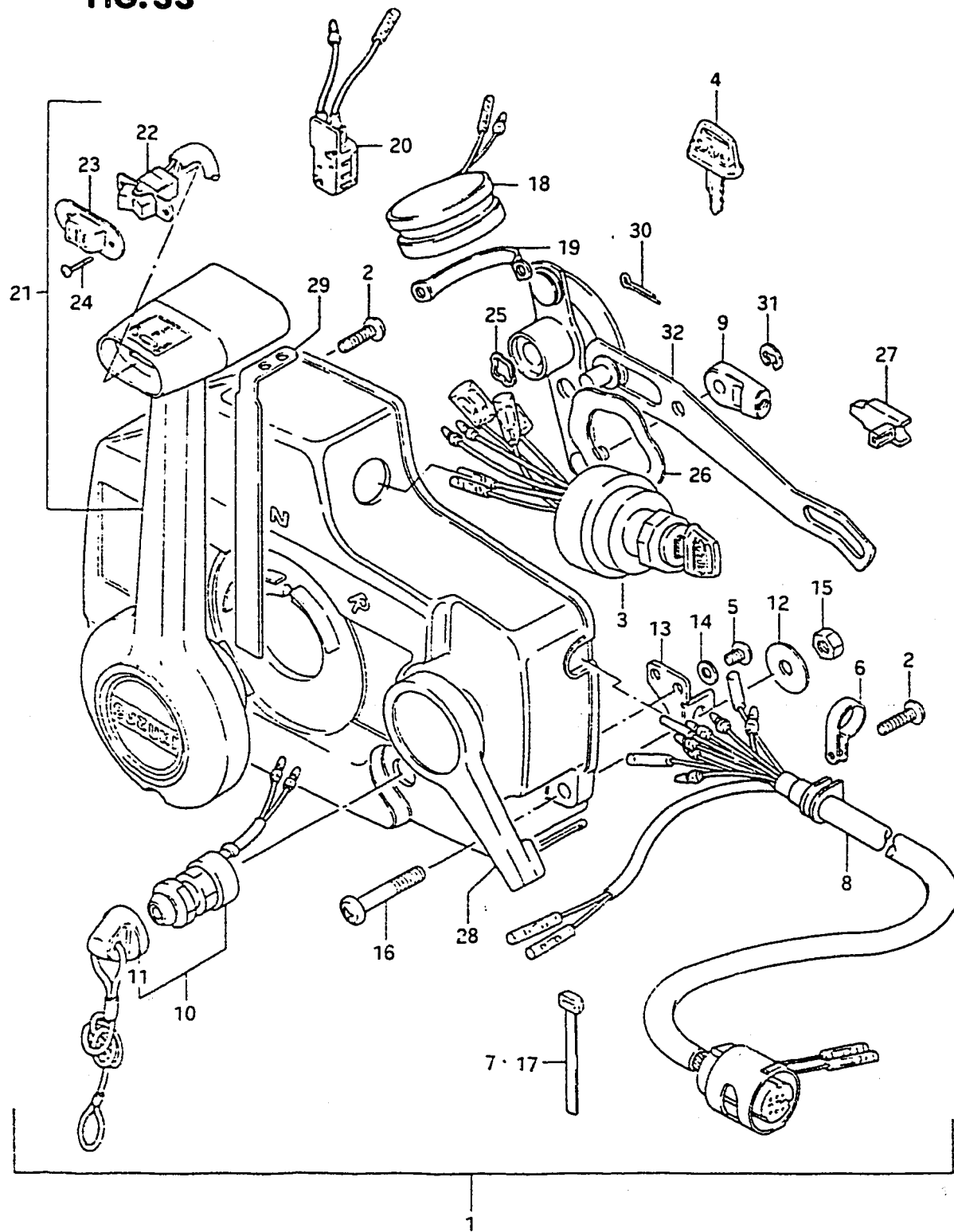
FIG. 33 ( E-10) REMOTE CONTROL (2)



REF.NO.	PART NO.	DESCRIPTION	Q'TY	REMARKS
1	67200-95561	REMOTE CONTROL BOX ASSY	1	model VE
2	67296-94300	.SCREW	3	
3	37110-94301	.SWITCH ASSY, ignition	1	
4-1	37141-93300	..KEY, spare (8511)	1	
4-2	37141-93310	..KEY, spare (8512)	1	
4-3	37141-93320	..KEY, spare (8513)	1	
4-4	37141-93330	..KEY, spare (8611)	1	
4-5	37141-93340	..KEY, spare (8612)	1	
4-6	37141-93350	..KEY, spare (8613)	1	
5	67296-94310	.SCREW	6	
6	36622-94300	.CLAMP	2	
7	36632-95501	.CLAMP	1	
8	36620-94310	.WIRING HARNESS	1	
9	67275-94300	.CABLE END	2	
10	37820-96302	.SWITCH, emergency	1	
11	37823-95251	..CAP	1	
12	67288-94300	.WASHER	6	
13	67271-94300	.HOLDER, cable	1	
14	67288-94310	.WASHER	3	
15	09140-06020	.NUT	3	
16	09125-06012	.SCREW	3	

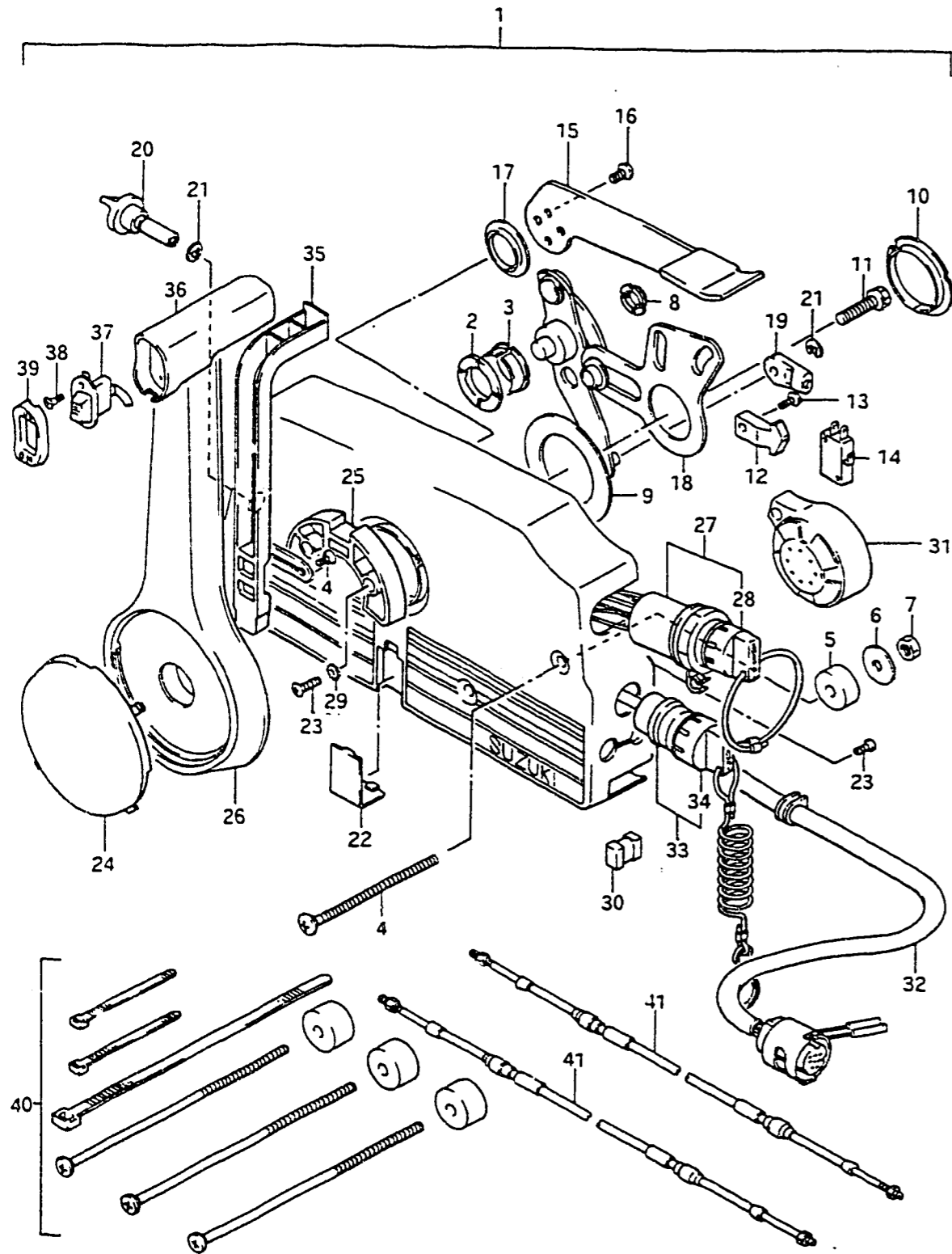
FIG.33

FIG.33 ( E-11) REMOTE CONTROL. (2)



REF.NO.	PART NO.	DESCRIPTION	Q'TY	REMARKS
17	37119-94300	.BAND	3	
18	38500-95503	.BUZZER, warning	1	
19	38501-95500	.BAND, warning buzzer	1	
20	37721-95551	.SWITCH ASSY, neutral	1	
21	67250-95302	.LEVER ASSY, remote control	1	
22	37860-94301	..SWITCH, trim	1	
23	37864-95500	..CAP, switch	1	
24	09139-02003	..SCREW	2	
25	67232-94300	.BUSH	1	
26	67252-94300	.BUSH	1	
27	67214-94300	.ACTUATOR	1	
28	67241-94300	.LEVER, free throttle	1	
29	67755-94300	.ARM, neutral lock	1	
30	67293-94300	.PIN	1	
31	67292-94300	.E RING	3	
32	67220-94300	.PLATE ASSY	1	

FIG.34



DT115TC VF E3

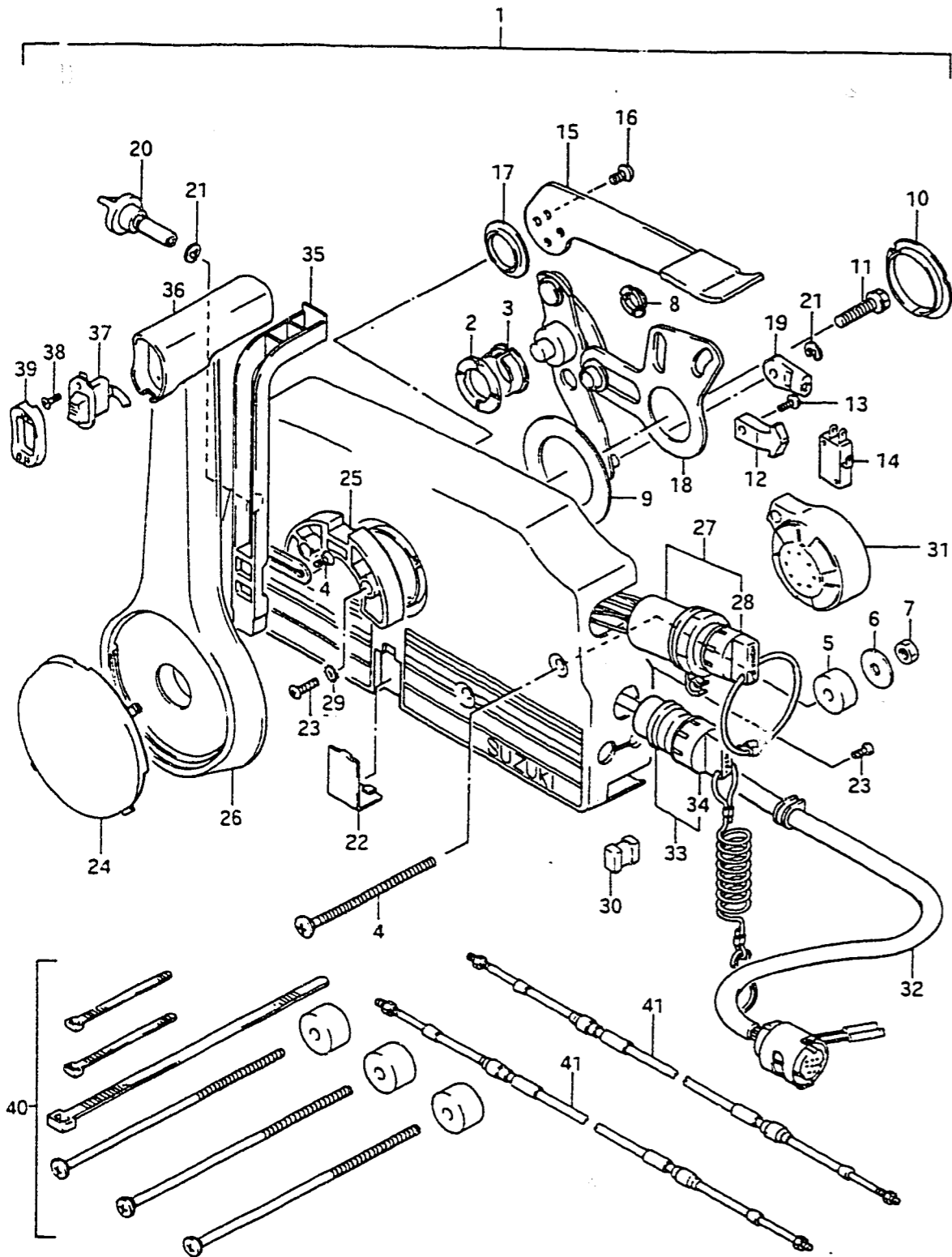
FIG.34 ( E-12) REMOTE CONTROL. (3)

REF.NO.	PART NO.	DESCRIPTION	Q'TY	REMARKS
1	67200-95651	REMOTE CONTROL BOX ASSY	1	model VF
2	67232-95600	.BUSH	1	
3	67232-95620	.BUSH	1	
4	67296-95600	.SCREW	3	
5	67294-95600	.SPACER	3	
6	67288-94310	.WASHER	3	
7	09140-06004	.NUT	3	
8	67232-95610	.BUSH	1	
9	67253-95600	.WASHER	1	
10	67252-95600	.BUSH	1	
11	09100-08232	.BOLT	1	
12	67214-95600	.ACTUATOR	1	
13	67296-94300	.SCREW	3	
14	37121-94600	.SWITCH, neutral	1	
15	67241-95650	.LEVER, free throt	1	
16	09126-05003	.SCREW	2	
17	67243-95600	.BUSH	1	
18	67220-95600	.PLATE ASSY	1	
19	67275-95600	.END, cable	2	
20	67223-95600	.KNOB, brake ADJ	1	
21	67292-94300	.E RING	3	
22	67267-95600	.COVER, wire	1	
23	67296-95610	.SCREW	7	
24	67257-95600	.CAP, lever	1	
25	67256-95600	.HOLDER, neut lock	1	
26	67251-95650	.LEVER HANDLE	1	
27	37110-94601	.IGNITION SWITCH	1	
28-1	37141-94400	..KEY (101)	1	
28-2	37141-94410	..KEY (102)	1	
28-3	37141-94420	..KEY (103)	1	
28-4	37141-94430	..KEY (104)	1	
28-5	37141-94440	..KEY (105)	1	
28-6	37141-94450	..KEY (106)	1	
29	67297-95600	.WASHER	2	
30	67273-95600	.SPACER	1	

DT1151C VF E3

FIG.34

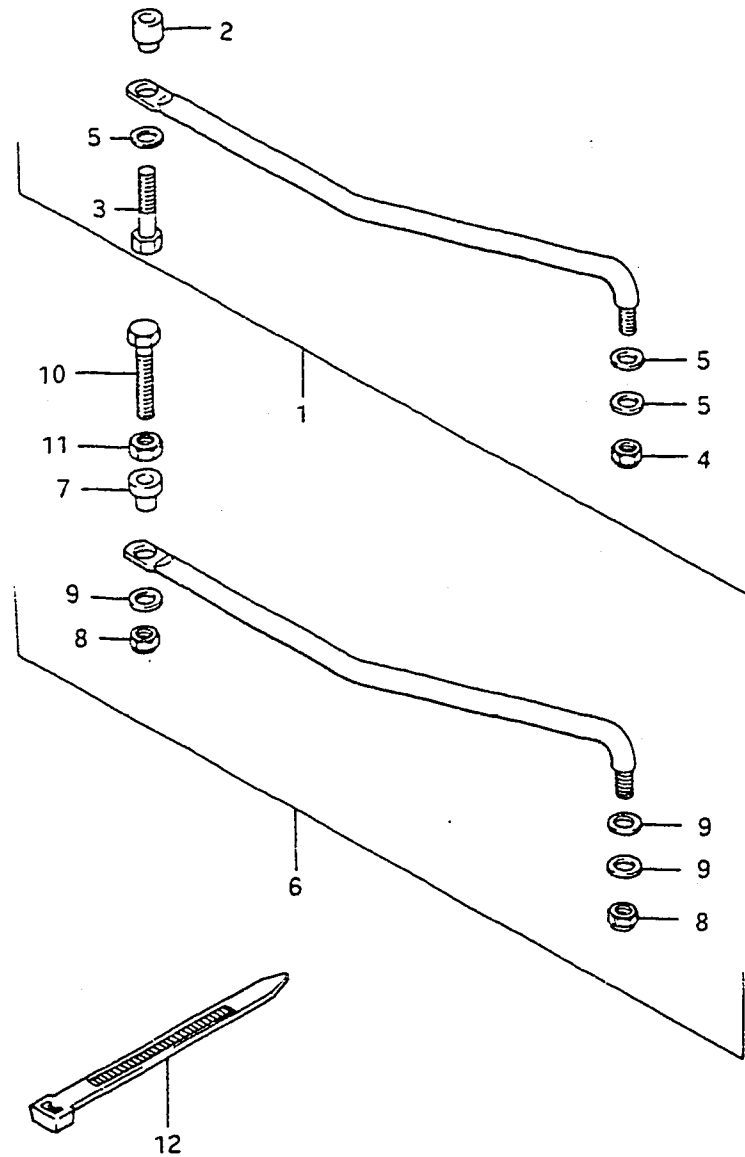
FIG.34 ( E-13) REMOTE CONTROL (3)



REF.NO.	PART NO.	DESCRIPTION	Q'TY	REMARKS
31	38500-87D00	.BUZZER	1	
32	36620-87D00	.WIRING HARNESS	1	
33	37820-94402	.SWITCH ASSY, emergency	1	
34	37823-94400	..CAP & ROPE	1	
35	67255-95600	.ARM NEUTRAL LOCK	1	
36	67261-95600	.GRIP	1	
37	37860-94600	.SWITCH, trim	1	
38	09139-02003	.SCREW	2	
39	67263-95600	.CAP GRIP	1	
40	67140-95600	ATTACHMENT, twin remocon kit	1	OPT
41-1	67320-95500	CABLE, clutch 6F (1.8M)	2	OPT
41-2	67320-95510	CABLE, clutch 7F (2.1M)	2	OPT
41-3	67320-95520	CABLE, clutch 8F (2.4M)	2	OPT
41-4	67320-95530	CABLE, clutch 9F (2.7M)	2	OPT
41-5	67320-95540	CABLE, clutch 10F (3.1M)	2	OPT
41-6	67320-95550	CABLE, clutch 11F (3.4M)	2	OPT
41-7	67320-95560	CABLE, clutch 12F (3.7M)	2	OPT
41-8	67320-95570	CABLE, clutch 13F (4.0M)	2	OPT
41-9	67320-95580	CABLE, clutch 14F (4.3M)	2	OPT
41-10	67320-95590	CABLE, clutch 15F (4.6M)	2	OPT
41-11	67320-95600	CABLE, clutch 16F (4.9M)	2	OPT
41-12	67320-95610	CABLE, clutch 17F (5.2M)	2	OPT
41-13	67320-95620	CABLE, clutch 18F (5.5M)	2	OPT
41-14	67320-95630	CABLE, clutch 19F (5.8M)	2	OPT
41-15	67320-95640	CABLE, clutch 20F (6.1M)	2	OPT
41-16	67320-95650	CABLE, clutch 22F (6.7M)	2	OPT

FIG. 35

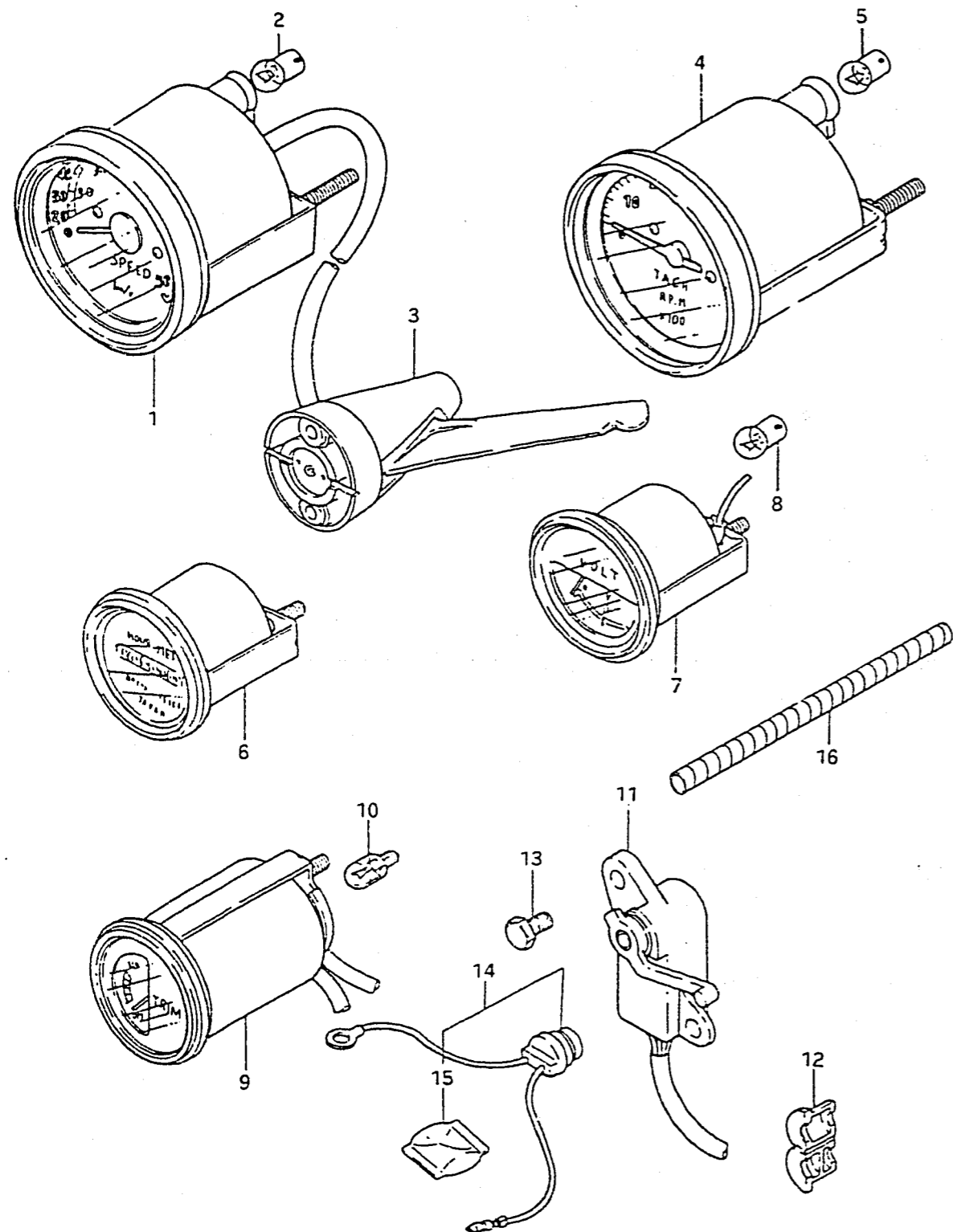
FIG.35 ( E-14) DRAG LINK



REF.NO.	PART NO.	DESCRIPTION	Q'TY	REMARKS
1	67701-94500	DRAG LINK ASSY	1	model QD/VE
2	67721-94500	.SPACER	1	
3	67725-94500	.BOLT	1	
4	67726-94500	.NUT, cock	1	
5	09160-10040	.WASHER	3	
6	67701-94510	DRAG LINK ASSY	1	model VF
7	67721-94510	.SPACER	1	
8	67726-94500	.NUT, lock	2	
9	67728-94500	.WASHER	3	
10	67725-94510	BOLT, drag link	1	model VF
11	67727-94510	NUT	1	model VF
12	36632-95501	CLAMP, steering cable seal	1	model VF

FIG. 36

FIG. 36 ( E-15) METER



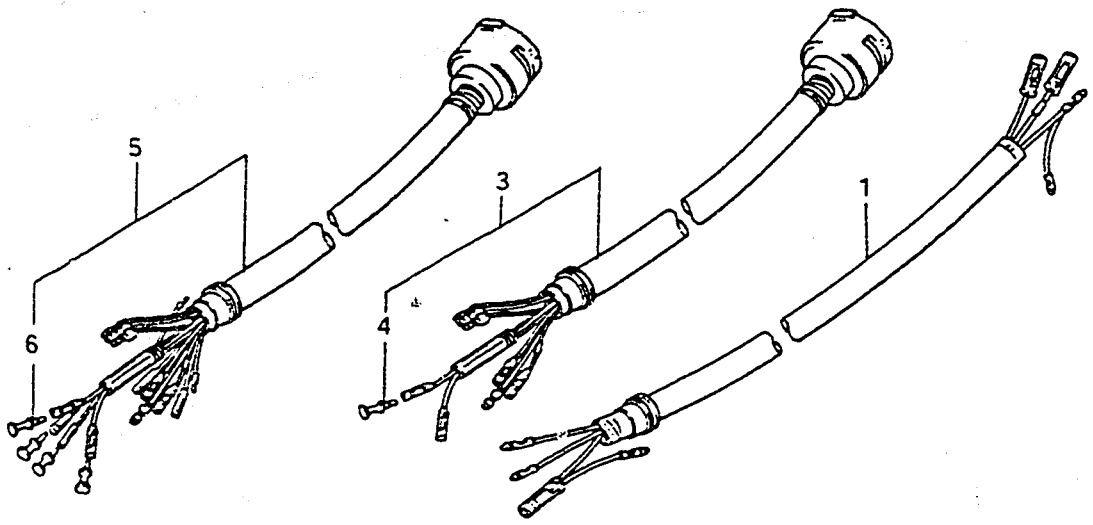
REF.NO.	PART NO.	DESCRIPTION	Q'TY	REMARKS
1-1	34100-94500	SPEEDOMETER ASSY	1	model QD/VE
1-2	34100-94501	SPEEDOMETER ASSY	1	model VF
1-3	34100-95501	SPEEDOMETER ASSY	1	model QD/VE
1-4	34100-95502	SPEEDOMETER ASSY	1	model VF
2	09471-12001	.BULB (12V,3.4W)	1	
3	34190-95500	.SENSOR, speedometer	1	
4-1	34200-95500	TACHOMETER ASSY	1	model QD/VE OPT
4-2	34200-95511	TACHOMETER ASSY	1	model VF
5	09471-12001	.BULB (12V,3.4W)	1	
6-1	34500-95502	HOURLMETER ASSY	1	NIPPON SEIKI
6-2	34500-95510	HOURLMETER ASSY	1	JECO (QUARTZ)
7-1	34600-95502	VOLT METER ASSY	1	model QD/VE
7-2	34600-95503	VOLT METER ASSY	1	model VF
8	09471-12001	.BULB (12V,3.4W)	1	
9-1	34800-95510	TRIM METER ASSY	1	model QD
9-2	34800-95520	TRIM METER ASSY	1	model VE
9-3	34800-95521	TRIM METER ASSY	1	model VF
10	09471-12077	.BULB (12V,1.7W)	1	
11-1	34801-94511	SENDER, trim	1	model QD
11-2	34801-94520	SENDER, trim	1	model VE/VF
12	34803-94500	GROMMET, lead	1	
13	09100-06019	BOLT	2	
14	34850-94510	HEAT SWITCH WITH GREASE	1	OPT
15	34855-95550	.GREASE, heat switch	1	OPT
16	34863-94300	TUBE (L:200)	1	

See Accessory Catalog for latest instrument specifications.

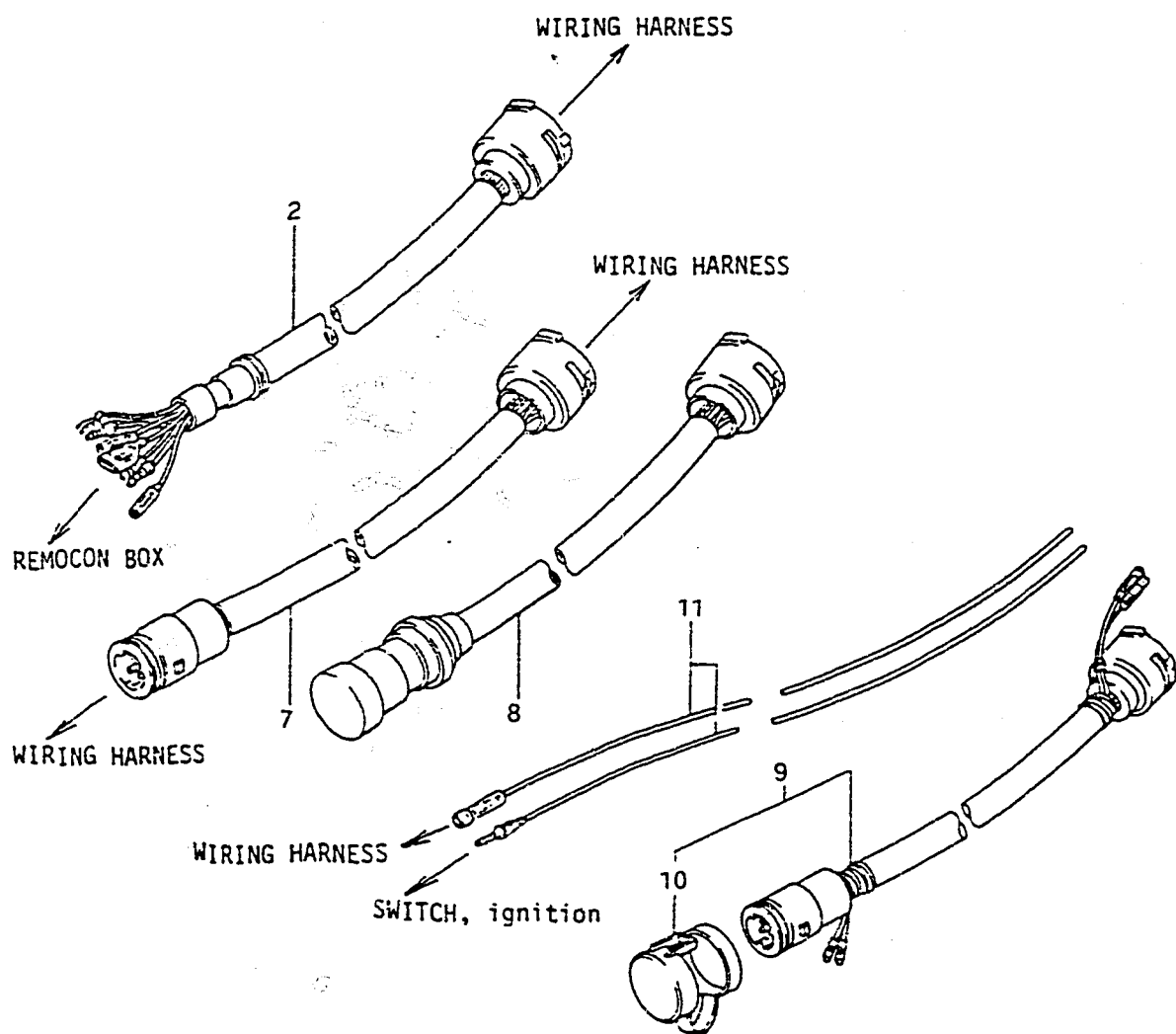


FIG.37

FIG.37 ( F- 2) OPT : ELECTRICAL

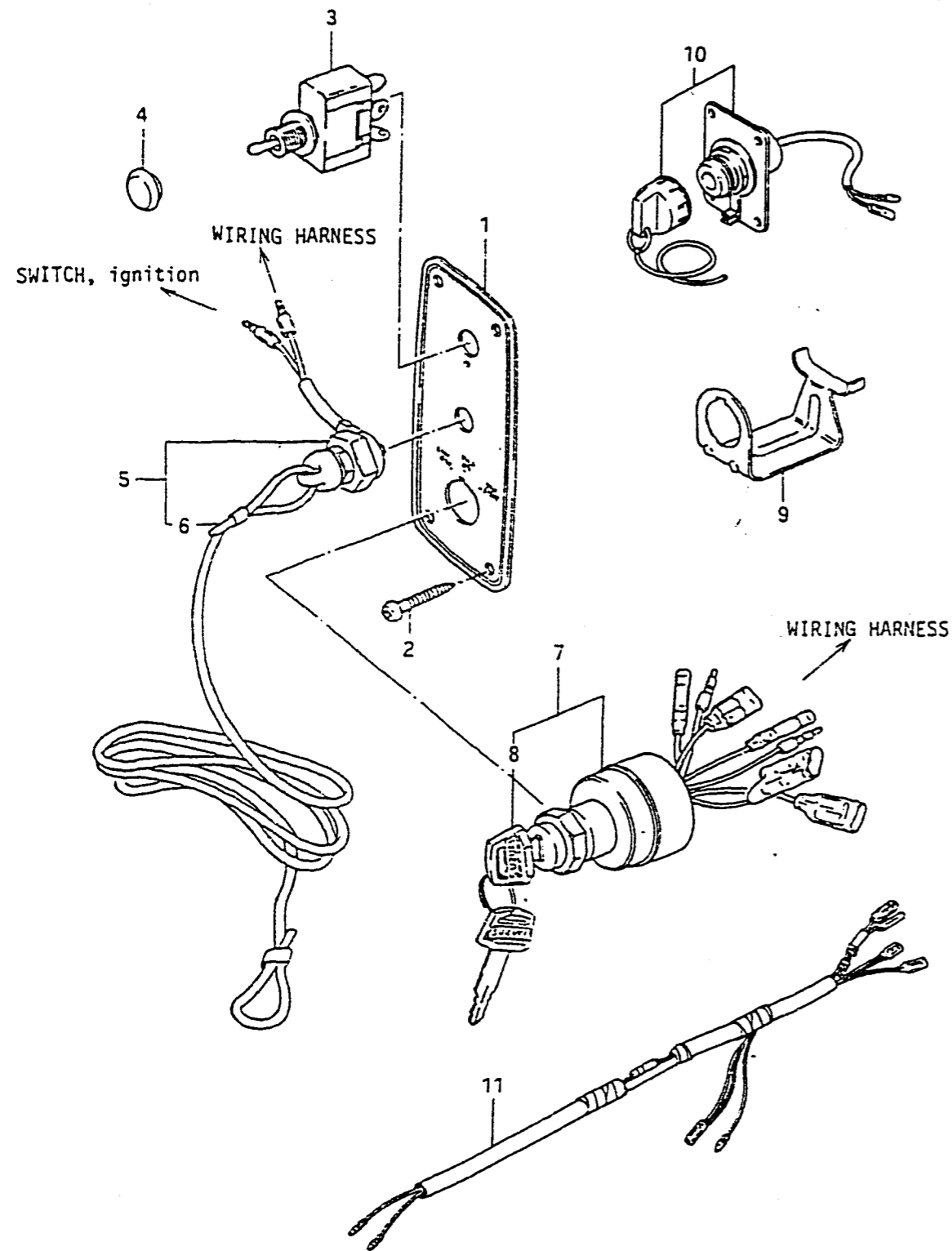


REF.NO.	PART NO.	DESCRIPTION	Q'TY	REMARKS
1	36640-95500	WIRING HARNESS, control	1	L:5000
2	36620-94501	WIRING HARNESS, extension	1	L:5000
3	36620-94510	WIRING HARNESS, extension	1	L:5000,model VE
4	36615-96300	.TERMINAL, resin	2	
5	36620-94520	WIRING HARNESS, extension	1	L:5000,model VF
6	36615-96300	.TERMINAL, resin	4	
7	36620-95202	WIRING HARNESS, extension	1	L:5000
8	36620-95203	WIRING HARNESS, extension	1	L:5000
9	36620-95320	WIRING HARNESS, ext 9 wires	1	L:5000
10	36631-94300	.CAP	1	
11	36820-95550	LEAD, neutral switch	1	L:700



**FIG. 38**

**FIG. 38 ( F- 3) OPT : IGNITION SWITCH**



REF.NO.	PART NO.	DESCRIPTION	Q'TY	REMARKS
1	37852-95550	PLATE, toggle switch	1	
2	03112-05129	SCREW	4	
3	37851-95250	SWITCH ASSY, toggle	1	model QD
4-1	37101-93301	CAP	1	model QD
4-2	37101-93310	CAP, panel assy	1	model VE/VF
5	37820-95353	SWITCH, emergency	1	
6	37823-95251	.COVER & ROPE	1	
7	37110-94301	SWITCH, ignition	1	
8-1	37141-93300	KEY, spare (8511)	1	
8-2	37141-93310	KEY, spare (8512)	1	
8-3	37141-93320	KEY, spare (8513)	1	
8-4	37141-93330	KEY, spare (8611)	1	
8-5	37141-93340	KEY, spare (8612)	1	
8-6	37141-93350	KEY, spare (8613)	1	
9	37150-93350	HOLDER, rope	1	
10	34108-94500	SWITCH ASSY, meter light	1	
11	34109-94500	LEAD, meter extension	1	

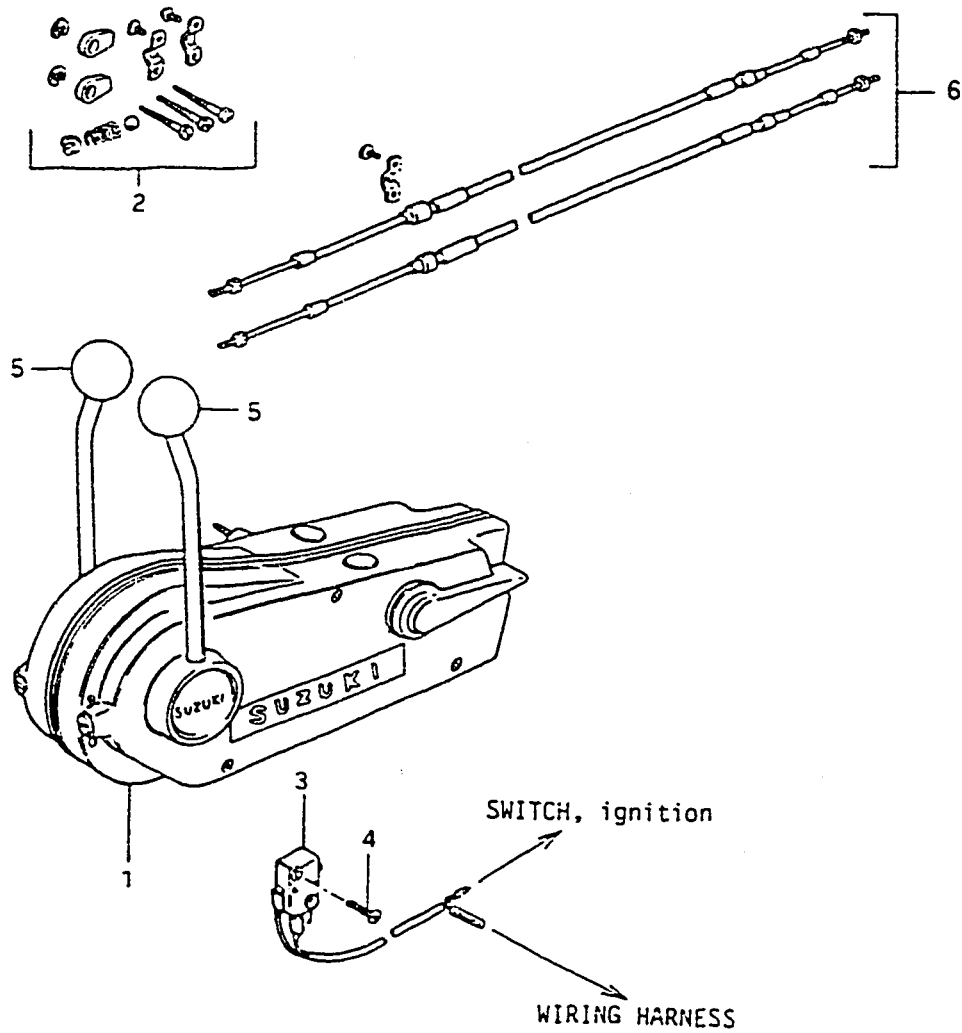
See Accessory Catalog for latest accessory information.

FIG. 39

FIG.39 ( F- 4) OPT : REMOTE CONTROL

Q'TY

REF.NO.	PART NO.	DESCRIPTION	Q'TY	REMARKS
1	67200-95871	REMOTE CONTROL BOX SET, TWIN	1	
2	67300-95810	.HOLDER SET, cable	1	
3	37721-95500	.SWITCH ASSY, neutral	2	
4	02112-03128	.SCREW	4	
5	67214-95200	.KNOB	2	
6-1	67320-95750	CABLE, control	2	L:2500
6-2	67320-95740	CABLE, control	2	L:3000
6-3	67320-95730	CABLE, control	2	L:3500
6-4	67320-95720	CABLE, control	2	L:4000
6-5	67320-95710	CABLE, control	2	L:4500
6-6	67320-95200	CABLE, control	2	L:5000



FWD

FIG. 40

FIG. 40 ( F- 5) OPTIONAL

Q'TY

REF.NO.	PART NO.	DESCRIPTION	Q'TY	REMARKS
1-1	99000-31010	L.IQUID GASKET	1	for crankcase
1-2	99000-31120	SILICONE SEAL	1	50g, for gear case
2	99000-31050	SILICONE SEALANT	1	100g, for gear case
3	99000-32040	CEMENT, thread lock	1	200g
4-1	99000-25160	GREASE, water resistant	1	250g
4-2	99000-25170	GREASE, water resistant	1	50g
5	99000-22540	GEAR OIL, outboard motor	1	400cc
6	99000-25010	SUPER GREASE A	1	450g, for crank oil seal
7-1	99000-32050	THREAD LOCK CEMENT	1	50g (1342)
7-2	99000-32020	THREAD LOCK CEMENT, super	1	50g (1333B)
9-1	99000-10109-01T	PAINT (90g)	1	
9-2	99000-10209-02M	PAINT (90g)	1	

